

AirTAC INTERNATIONAL GROUP

**BIBUS<sup>®</sup>** AirTAC

## Lineaire Geleidingen (2022A)

- LSH Series Standard Linear Guide
- LSD Series Low Profile Type Linear Guide
- LRM Series Miniature Linear Guide
- LGC Series Crossed Roller Way

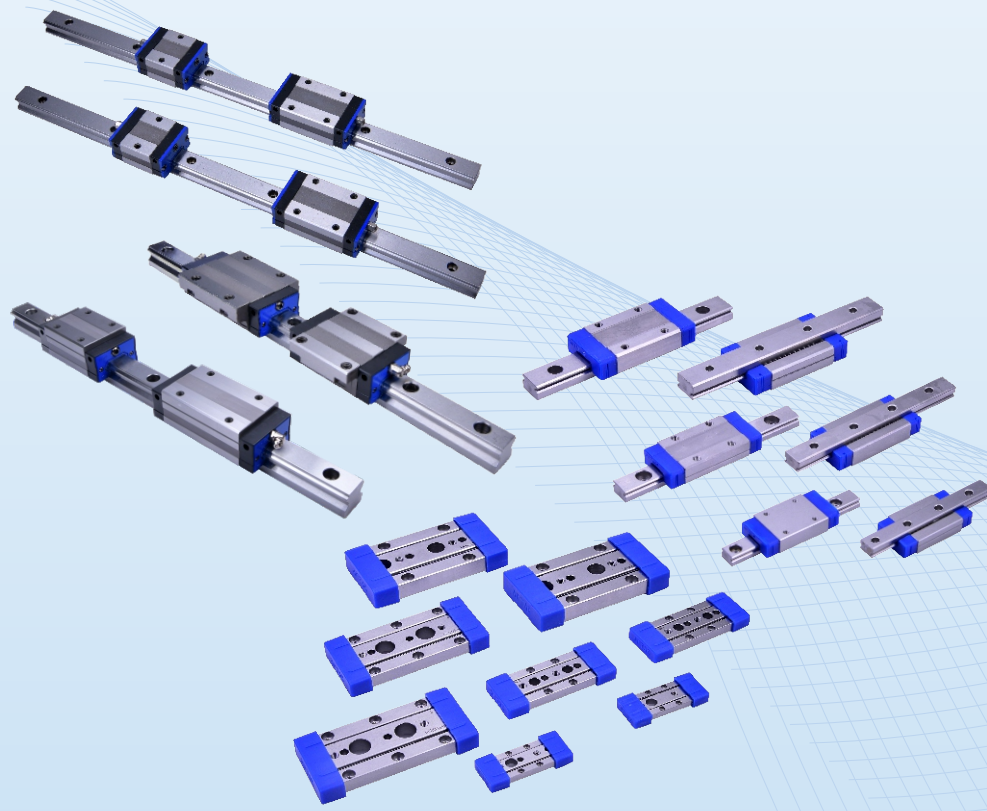

### BIBUS BV

- [BIBUS.nl](http://BIBUS.nl)
- [Sales@BIBUS.nl](mailto:Sales@BIBUS.nl)
- +31(0) 252 433733
- Meer en Duin 295
- 2163 HE Lisse
- Nederland



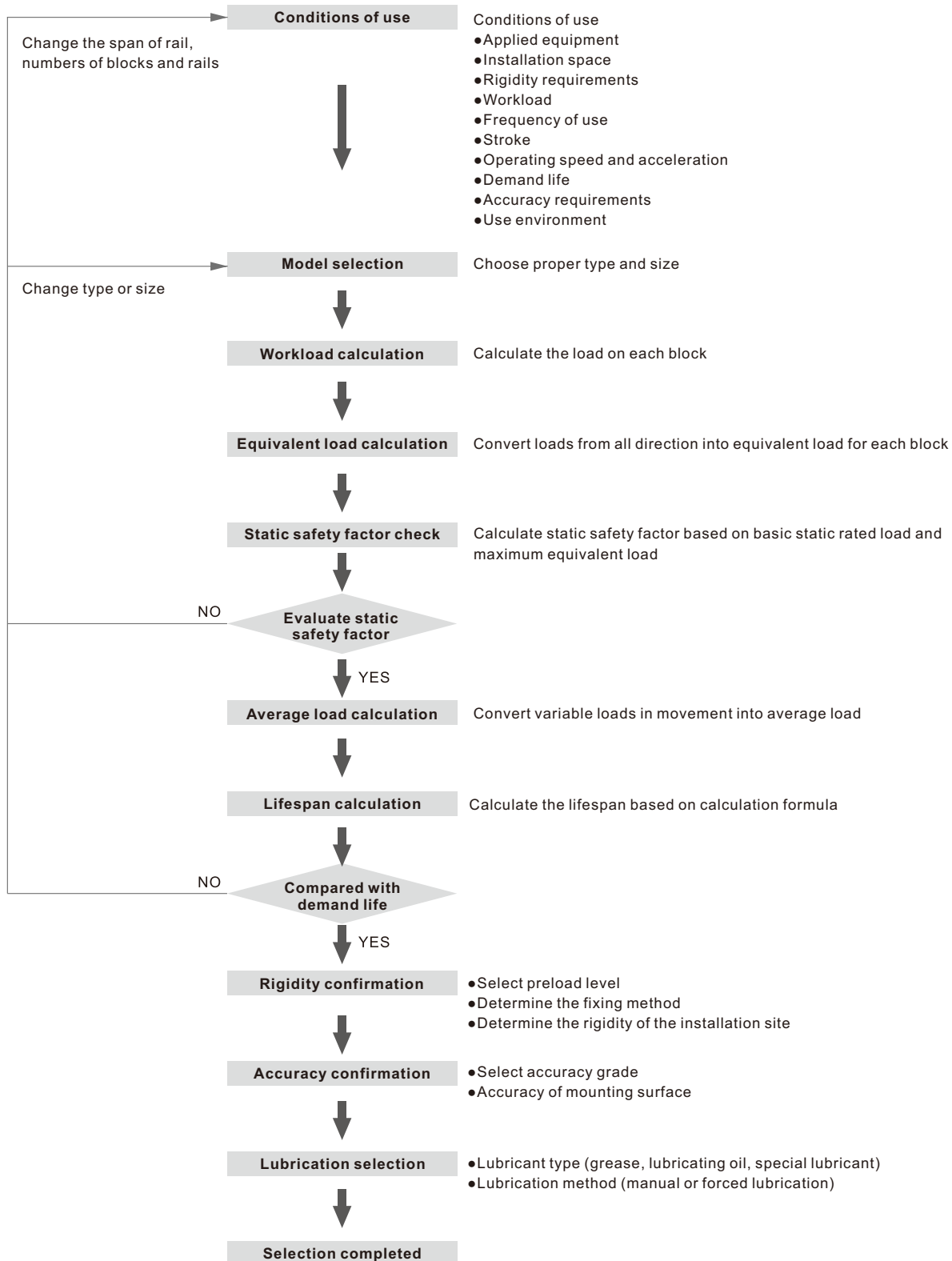



## Linear Guide Selection

### Load Capacity and Rating Life

#### 1. Basic static load rating ( $C_0$ )

When a linear guide absorbs a large force or impact in a static or low-speed movement, it will cause permanent deformation either on rollers and groove. When sum of deformation on groove and rollers exceeds a certain limit, it will affect the smoothness of its linear movement.

Basic static load rating is defined as the magnitude of a given stress applied at where the stress is the biggest caused the sum of permanent deformation on groove and roller is 1/10000 of the diameter of the rollers.

#### 2. Allowable static moment ( $M_0$ )

When torque is applied on a linear guide, rollers in the both ends of block will endure the major stress force.

Allowable static moment is defined as a given moment applied and raised stress force on linear guide which will cause sum of permanent deformation on groove and roller is 1/10000 of the diameter of the rollers.

Static moment is defined in three directions as  $M_p$ ,  $M_v$ ,  $M_R$ .

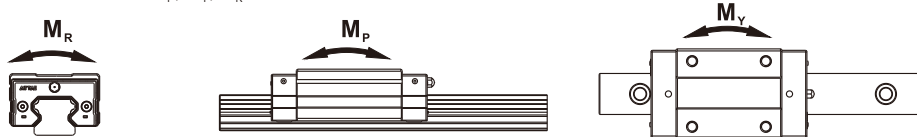

#### 3. Static safety factor ( $f_s$ )

During vibration, impact or sudden start and stop, the inertia force or torque will raise huge loads on linear guide. For this kind of situation, it is necessary to put static safety factor into consideration. Static safety factor is a ratio of the basic static load rating to the calculated working load as shown in following formula. The reference of static safety factor for different conditions is shown in following table:

Use machinery	Load condition	$f_s$
General industrial machinery	General load conditions	1.0~1.3
	When there is vibration or shock	2.0~3.0
Machine tool	General load conditions	1.0~1.5
	When there is vibration or shock	2.5~7.0

$$f_s = \frac{C_0}{P} \text{ or } f_s = \frac{M_0}{M}$$

$f_s$ : Static safety factor  
 $C_0$ : Basic static load rating (N)  
 $M_0$ : Allowable static moment (N·m)  
 $P$ : Calculation load (N)  
 $M$ : Calculation moment (N·m)

#### 4. Basic dynamic load rating (C)

Basic Dynamic Load rating is defined as the maximum allowable load and can be applied on the same specification of linear guides. This will result in a nominal life of 50 KM operation for linear guide.

#### 5. Life calculation

##### •Life

When a linear guide is with bearings loaded during operation, the groove and rollers will constantly endure stress force. Once reaching fatigue, the surface will peel off and damage. The life of a given linear guide is defined as the moving distance of a linear guide in which peeling occurs due to fatigue.

##### •Nominal life

Actual lifespan of linear guide varies enormously. The lifespan of each guide can be different even though they come from the same product batch under the same condition. Therefore, nominal life is usually chosen as bench mark to evaluate lifespan. Nominal life is defined as the moving distance for 90% of linear guides from the same production batch which can perform under the same working condition without peeling.

##### •Life factor

##### 1. Hardness factor ( $f_H$ )

Surface hardness of rollers must be HRC 58~62. A softer hardness will reduce load-bearing performance and static load rating. Therefore allowable moment must be multiplied by a hardness factor as correlation shown on the right chart. Our hardness requirement for linear guide is HRC58~62, therefore  $f_H = 1.0$ .

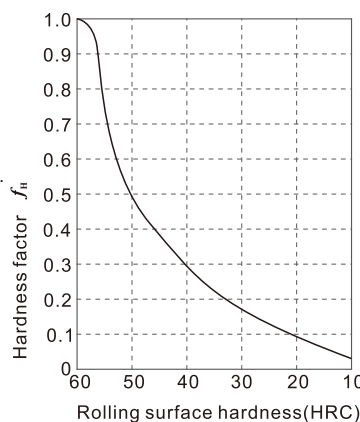

##### 2. Temperature factor ( $f_T$ )

High temperature environment will affect lifespan of the linear guide. Therefore, static load rating and allowable moment must be multiplied by a temperature factor  $f_T$  as correlation shown on the right graph.

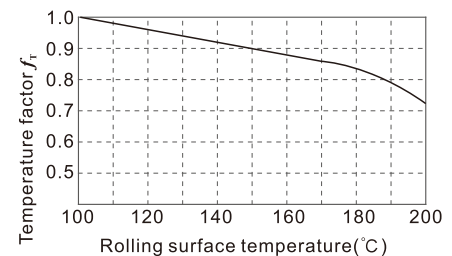

Certain parts of our linear guide are made of plastic and rubber, hence working in temperature higher than 100 is not recommended.

##### 3. Load factor ( $f_w$ )

Although loads on a given linear guide can be calculated, it will usually come with vibration or hitting in actual use. This makes actual loads higher than calculated figure. Hence, in heavy vibration or hitting condition, please divide basic dynamic load rating (C) by following empirical load factor.

Working Conditions	Use speed	$f_w$
Smooth without impact	$V \leq 15\text{m/min}$	1.0~1.2
Common impact and vibration	$15\text{m/min} < V \leq 60\text{m/min}$	1.2~1.5
Moderate impact and vibration	$60\text{m/min} < V \leq 120\text{m/min}$	1.5~2.0
Strong impact and vibration	$V \geq 120\text{m/min}$	2.0~3.5

# Linear Guide

## Linear Guide Selection

### ● Calculation of nominal life(L)

The nominal life will vary based on applied load. Hardness and working temperature will also have great effects on lifespan of a linear guide. Putting all factors into consideration, nominal life can be calculated by following formula:

$$L = \left( \frac{f_H \times f_T \times C}{f_W \times P} \right)^3 \times 50Km$$

- L : Nominal life (km)
- C : Basic dynamic load rating (N)
- P : Workload (N)
- f<sub>w</sub> : Load factor
- f<sub>H</sub> : Hardness factor
- f<sub>T</sub> : Temperature factor

### ● Calculation of service life time(L<sub>s</sub>)

If stroke length and repeating time are known, service life time (L<sub>s</sub>) can be derived based on rated life (L)

$$L_h = \frac{L \times 10^3}{2 \times l_s \times n_1 \times 60}$$

- L<sub>s</sub> : Service life time (hr)
- L : Rated life (km)
- l<sub>s</sub> : Stroke length (m)
- n<sub>1</sub> : Rounds per minute (min<sup>-1</sup>)

## Calculation of working load

Load effect on a linear guide will be affected by its center of mass, position of thrust and inertia force occurring by acceleration when starting or stopping, etcetera. Therefore, most applications of working conditions must be put into consideration in order to acquire accurate nominal life.

### Working load calculation

Type	Operation condition	Load on each block
Horizontal use uniform motion Or at rest		$P_1 = \frac{F}{4} + \frac{Fl_2}{2l_1} - \frac{Fl_4}{2l_2}$ $P_2 = \frac{F}{4} - \frac{Fl_2}{2l_1} - \frac{Fl_4}{2l_2}$ $P_3 = \frac{F}{4} - \frac{Fl_2}{2l_1} + \frac{Fl_4}{2l_2}$ $P_4 = \frac{F}{4} + \frac{Fl_2}{2l_1} + \frac{Fl_4}{2l_2}$
Horizontal cantilever use uniform motion Or at rest		$P_1 = \frac{F}{4} + \frac{Fl_2}{2l_1} + \frac{Fl_4}{2l_2}$ $P_2 = \frac{F}{4} - \frac{Fl_2}{2l_1} + \frac{Fl_4}{2l_2}$ $P_3 = \frac{F}{4} - \frac{Fl_2}{2l_1} - \frac{Fl_4}{2l_2}$ $P_4 = \frac{F}{4} + \frac{Fl_2}{2l_1} - \frac{Fl_4}{2l_2}$
Vertical use uniform motion Or at rest		$P_1 = P_2 = P_3 = P_4 = \frac{Fl_2}{2l_1}$ $P_{1T} = P_{2T} = P_{3T} = P_{4T} = \frac{Fl_1}{2l_2}$
Wall-mounted use uniform motion Or at rest		$P_1 = P_2 = P_3 = P_4 = \frac{Fl_2}{2l_1}$ $P_{1T} = P_{4T} = \frac{F}{4} + \frac{Fl_3}{2l_1}$ $P_{2T} = P_{3T} = \frac{F}{4} - \frac{Fl_3}{2l_1}$



## Linear Guide Selection

Type	Operation condition	Load on each block
Lateral Slope		$P_1 = \frac{F \cdot \cos\theta}{4} + \frac{F \cdot \cos\theta \cdot l_3}{2 \cdot l_1} - \frac{F \cdot \cos\theta \cdot l_4}{2 \cdot l_2} + \frac{F \cdot \sin\theta \cdot h_1}{2 \cdot l_2}$ $P_2 = \frac{F \cdot \cos\theta}{4} - \frac{F \cdot \cos\theta \cdot l_3}{2 \cdot l_1} - \frac{F \cdot \cos\theta \cdot l_4}{2 \cdot l_2} + \frac{F \cdot \sin\theta \cdot h_1}{2 \cdot l_2}$ $P_3 = \frac{F \cdot \cos\theta}{4} - \frac{F \cdot \cos\theta \cdot l_3}{2 \cdot l_1} + \frac{F \cdot \cos\theta \cdot l_4}{2 \cdot l_2} - \frac{F \cdot \sin\theta \cdot h_1}{2 \cdot l_2}$ $P_4 = \frac{F \cdot \cos\theta}{4} + \frac{F \cdot \cos\theta \cdot l_3}{2 \cdot l_1} + \frac{F \cdot \cos\theta \cdot l_4}{2 \cdot l_2} - \frac{F \cdot \sin\theta \cdot h_1}{2 \cdot l_2}$ $P_{1T} = P_{4T} = \frac{F \cdot \sin\theta}{4} + \frac{F \cdot \sin\theta \cdot l_3}{2 \cdot l_1}$ $P_{2T} = P_{3T} = \frac{F \cdot \sin\theta}{4} - \frac{F \cdot \sin\theta \cdot l_3}{2 \cdot l_1}$
Axial Slope		$P_1 = \frac{F \cdot \cos\theta}{4} + \frac{F \cdot \cos\theta \cdot l_3}{2 \cdot l_1} - \frac{F \cdot \cos\theta \cdot l_4}{2 \cdot l_2} + \frac{F \cdot \sin\theta \cdot h_1}{2 \cdot l_1}$ $P_2 = \frac{F \cdot \cos\theta}{4} - \frac{F \cdot \cos\theta \cdot l_3}{2 \cdot l_1} - \frac{F \cdot \cos\theta \cdot l_4}{2 \cdot l_2} - \frac{F \cdot \sin\theta \cdot h_1}{2 \cdot l_1}$ $P_3 = \frac{F \cdot \cos\theta}{4} - \frac{F \cdot \cos\theta \cdot l_3}{2 \cdot l_1} + \frac{F \cdot \cos\theta \cdot l_4}{2 \cdot l_2} - \frac{F \cdot \sin\theta \cdot h_1}{2 \cdot l_1}$ $P_4 = \frac{F \cdot \cos\theta}{4} + \frac{F \cdot \cos\theta \cdot l_3}{2 \cdot l_1} + \frac{F \cdot \cos\theta \cdot l_4}{2 \cdot l_2} + \frac{F \cdot \sin\theta \cdot h_1}{2 \cdot l_1}$ $P_{1T} = P_{4T} = + \frac{F \cdot \sin\theta \cdot l_4}{2 \cdot l_1}$ $P_{2T} = P_{3T} = - \frac{F \cdot \sin\theta \cdot l_4}{2 \cdot l_1}$
Use horizontally with inertial force		<p>When accelerating</p> $P_1 = P_4 = \frac{mg}{4} - \frac{m \cdot a_i \cdot l_3}{2 \cdot l_1}$ $P_2 = P_3 = \frac{mg}{4} + \frac{m \cdot a_i \cdot l_3}{2 \cdot l_1}$ $P_{1T} = P_{2T} = P_{3T} = P_{4T} = \frac{m \cdot a_i \cdot l_4}{2 \cdot l_1}$ <p>When decelerating</p> $P_1 = P_4 = \frac{mg}{4} + \frac{m \cdot a_i \cdot l_3}{2 \cdot l_1}$ $P_2 = P_3 = \frac{mg}{4} - \frac{m \cdot a_i \cdot l_3}{2 \cdot l_1}$ $P_{1T} = P_{2T} = P_{3T} = P_{4T} = \frac{m \cdot a_i \cdot l_4}{2 \cdot l_1}$ <p>At constant speed</p> $P_1 = P_2 = P_3 = P_4 = \frac{mg}{4}$
Use Vertically with inertial force		<p>When accelerating</p> $P_1 = P_2 = P_3 = P_4 = \frac{m \cdot (g + a_i) \cdot l_3}{2 \cdot l_1}$ $P_{1T} = P_{2T} = P_{3T} = P_{4T} = \frac{m \cdot (g + a_i) \cdot l_4}{2 \cdot l_1}$ <p>When decelerating</p> $P_1 = P_2 = P_3 = P_4 = \frac{m \cdot (g - a_i) \cdot l_3}{2 \cdot l_1}$ $P_{1T} = P_{2T} = P_{3T} = P_{4T} = \frac{m \cdot (g - a_i) \cdot l_4}{2 \cdot l_1}$ <p>At constant speed</p> $P_1 = P_2 = P_3 = P_4 = \frac{mg \cdot l_3}{2 \cdot l_1}$ $P_{1T} = P_{2T} = P_{3T} = P_{4T} = \frac{mg \cdot l_4}{2 \cdot l_1}$

## Linear Guide Selection

### Calculation of equivalent load

A block can bear force as well as torque from all axial and radial directions. When multiple loads are applied, these loads can be combined as an equivalent axial and radial load for the calculation of nominal life or static safety factor.

Our linear guide can bear loads in four directions, up, down, left, and right. So when using linear slides, it may be subjected to vertical load ( $P_R$ ) and lateral load ( $P_T$ ) at the same time. When two or more linear guides are used, the equivalent load ( $P_E$ ) can be converted according to the following formula.

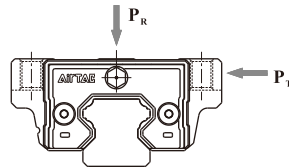

$$P_E = |P_R| + |P_T|$$

- $P_E$  : Equivalent load (N)
- $P_R$  : Radial load (N)
- $P_T$  : Lateral load (N)

In the case of single linear guide, equivalent load must take torque into account, see following formula.

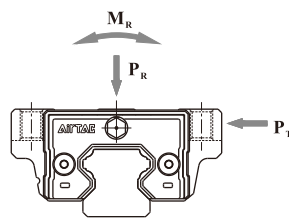

$$P_E = |P_R| + |P_T| + C_0 \frac{|M|}{M_R}$$

- $P_E$  : Equivalent load (N)
- $P_R$  : Radial load (N)
- $P_T$  : Lateral load (N)
- $C_0$  : Basic static load rating (N)
- $M$  : Calculated torque (N·m)
- $M_R$  : Allowable static moment (N·m)

### Calculation of average load

The real-time acting load for a block during movement is always variable. One can derive average load for the use of rated life calculation based on different applications. Average load when rollers are steel ball is as follows:

$$P_m = e \sqrt{\frac{1}{L} \cdot \sum_{n=1}^n (P_n^e \cdot L_n)}$$

- $P_m$  : Average load (N)
- $P_n$  : Variable load (N)
- $L$  : Total Working Distance (mm)
- $L_n$  : Moving distance when load  $P_n$  applied (mm)
- $e$  : Exponent (for steel ball: 3)

#### Average load calculation example

Varying load type	Average load calculation
<p>Interval Variable Load</p>	$P_m = e \sqrt{\frac{1}{L} \cdot (P_1^e \cdot L_1 + P_2^e \cdot L_2 + \dots + P_n^e \cdot L_n)}$ <ul style="list-style-type: none"> <li><math>P_m</math> : Average load (N)</li> <li><math>P_n</math> : Variable load (N)</li> <li><math>L</math> : Total Working Distance (mm)</li> <li><math>L_n</math> : Moving distance when load <math>P_n</math> applied (mm)</li> <li><math>e</math> : Exponent (for steel ball: 3)</li> </ul>
<p>Monotonic variable load</p>	$P_m \approx \frac{1}{3} (P_{min} + 2 \cdot P_{max})$ <ul style="list-style-type: none"> <li><math>P_m</math> : Average load (N)</li> <li><math>P_{min}</math> : Minimum load (N)</li> <li><math>P_{max}</math> : Maximum load (N)</li> </ul>

## Linear Guide Selection

Varying load type	Average load calculation
<p>Sinusoidal variable load</p>	$P_m \approx 0.65 \cdot P_{max}$ <p><math>P_m</math>: Average load (N)  <math>P_{max}</math>: Maximum load (N)</p>
	$P_m \approx 0.75 \cdot P_{max}$ <p><math>P_m</math>: Average load (N)  <math>P_{max}</math>: Maximum load (N)</p>

### Calculation example

Conditions of Use	Load calculation of each block
<p>Model : LSH30HL2X2520S20BP-M6(2 pcs)</p> <p>Basic dynamic load rating : <math>C=45.7 KN</math></p> <p>Basic static load rating : <math>C_0=73.1 KN</math></p> <p>Mass <math>m_1=700kg</math> <math>m_2=450kg</math></p> <p>Speed <math>V=0.75m/s</math></p> <p>Time <math>t_1=0.05s</math> <math>t_2=1.9s</math> <math>t_3=0.15s</math></p> <p>Acceleration <math>a_1=15m/s^2</math> <math>a_3=5m/s^2</math></p> <p>Travel Distance <math>l_2=1500mm</math></p> <p>Distance <math>l_1=650mm</math> <math>l_2=450mm</math> <math>l_3=135mm</math> <math>l_4=60mm</math> <math>l_5=175mm</math> <math>l_6=400mm</math></p>	<p>At constant speed, the radial load <math>P_r</math></p> $P_1 = \frac{m_1 g}{4} - \frac{m_1 g \cdot l_1}{2l_1} + \frac{m_2 g \cdot l_2}{2l_2} + \frac{m_3 g}{4} = 2562N$ $P_2 = \frac{m_1 g}{4} + \frac{m_1 g \cdot l_1}{2l_1} + \frac{m_2 g \cdot l_2}{2l_2} + \frac{m_3 g}{4} = 3987N$ $P_3 = \frac{m_1 g}{4} + \frac{m_1 g \cdot l_1}{2l_1} - \frac{m_2 g \cdot l_2}{2l_2} + \frac{m_3 g}{4} = 3073N$ $P_4 = \frac{m_1 g}{4} - \frac{m_1 g \cdot l_1}{2l_1} - \frac{m_2 g \cdot l_2}{2l_2} + \frac{m_3 g}{4} = 1648N$ <p>Acceleration is toward left, the radial load <math>P_r a_i</math></p> $P_1 a_i = P_1 - \frac{m_1 a_i \cdot l_1}{2l_1} - \frac{m_2 a_i \cdot l_2}{2l_2} = -1577N$ $P_2 a_i = P_2 + \frac{m_1 a_i \cdot l_1}{2l_1} + \frac{m_2 a_i \cdot l_2}{2l_2} = 8127N$ $P_3 a_i = P_3 + \frac{m_1 a_i \cdot l_1}{2l_1} + \frac{m_2 a_i \cdot l_2}{2l_2} = 7212N$ $P_4 a_i = P_4 - \frac{m_1 a_i \cdot l_1}{2l_1} - \frac{m_2 a_i \cdot l_2}{2l_2} = -2492N$ <p>Lateral load <math>P_{t_i} a_i</math></p> $P_{t_1} a_i = -\frac{m_1 a_i \cdot l_1}{2l_1} = -485N$ $P_{t_2} a_i = \frac{m_1 a_i \cdot l_1}{2l_1} = 485N$ $P_{t_3} a_i = \frac{m_1 a_i \cdot l_1}{2l_1} = 485N$ $P_{t_4} a_i = -\frac{m_1 a_i \cdot l_1}{2l_1} = -485N$

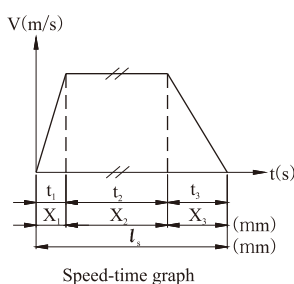
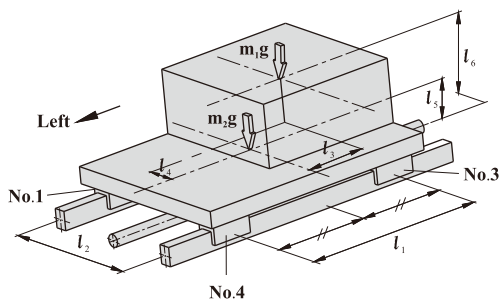



# Linear Guide

## Linear Guide Selection

### Conditions of Use

Model : LSH30HL2X2520S20BP-M6(2 pcs)

Basic dynamic load rating :  $C=45.7 KN$

Basic static load rating :  $C_0=73.1 KN$

Mass  $m_1=700kg$   $m_2=450kg$

Speed  $V=0.75m/s$

Time  $t_1=0.05s$   $t_2=1.9s$   $t_3=0.15s$

Acceleration  $a_1=15m/s^2$   $a_3=5m/s^2$

Travel Distance  $l_s=1500mm$

Distance  $l_1=650mm$   $l_2=450mm$   $l_3=135mm$   $l_4=60mm$   $l_5=175mm$   $l_6=400mm$

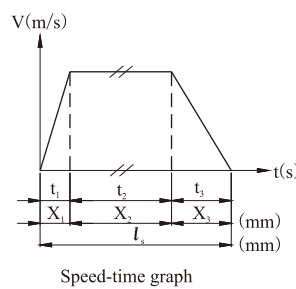
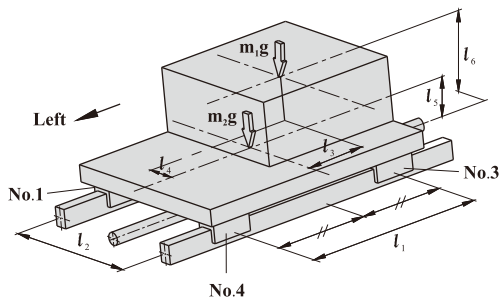

### Load calculation of each block

Deceleration is toward left, the radial load  $P_{r1}a_3$

$$P_{r1}a_3 = P_1 + \frac{m_1 \cdot a_3 \cdot l_6}{2l_1} + \frac{m_2 \cdot a_3 \cdot l_5}{2l_1} = 3942N$$

$$P_{r2}a_3 = P_2 - \frac{m_1 \cdot a_3 \cdot l_6}{2l_1} - \frac{m_2 \cdot a_3 \cdot l_5}{2l_1} = 2607N$$

$$P_{r3}a_3 = P_3 - \frac{m_1 \cdot a_3 \cdot l_6}{2l_1} - \frac{m_2 \cdot a_3 \cdot l_5}{2l_1} = 1693N$$

$$P_{r4}a_3 = P_4 + \frac{m_1 \cdot a_3 \cdot l_6}{2l_1} + \frac{m_2 \cdot a_3 \cdot l_5}{2l_1} = 3028N$$

Lateral load  $P_{t1}a_3$

$$P_{t1}a_3 = \frac{m_1 \cdot a_3 \cdot l_4}{2l_1} = 162N$$

$$P_{t2}a_3 = -\frac{m_1 \cdot a_3 \cdot l_4}{2l_1} = -162N$$

$$P_{t3}a_3 = -\frac{m_1 \cdot a_3 \cdot l_4}{2l_1} = -162N$$

$$P_{t4}a_3 = \frac{m_1 \cdot a_3 \cdot l_4}{2l_1} = 162N$$

Acceleration is toward right, the radial load  $P_{r1}a_1$

$$P_{r1}a_1 = P_1 + \frac{m_1 \cdot a_1 \cdot l_6}{2l_1} + \frac{m_2 \cdot a_1 \cdot l_5}{2l_1} = 6702N$$

$$P_{r2}a_1 = P_2 - \frac{m_1 \cdot a_1 \cdot l_6}{2l_1} - \frac{m_2 \cdot a_1 \cdot l_5}{2l_1} = -152N$$

$$P_{r3}a_1 = P_3 - \frac{m_1 \cdot a_1 \cdot l_6}{2l_1} - \frac{m_2 \cdot a_1 \cdot l_5}{2l_1} = -1067N$$

$$P_{r4}a_1 = P_4 + \frac{m_1 \cdot a_1 \cdot l_6}{2l_1} + \frac{m_2 \cdot a_1 \cdot l_5}{2l_1} = 5787N$$

Lateral load  $P_{t1}a_1$

$$P_{t1}a_1 = \frac{m_1 \cdot a_1 \cdot l_4}{2l_1} = 485N$$

$$P_{t2}a_1 = -\frac{m_1 \cdot a_1 \cdot l_4}{2l_1} = -485N$$

$$P_{t3}a_1 = -\frac{m_1 \cdot a_1 \cdot l_4}{2l_1} = -485N$$

$$P_{t4}a_1 = \frac{m_1 \cdot a_1 \cdot l_4}{2l_1} = 485N$$

Deceleration is toward right, the radial load  $P_{r1}a_3$

$$P_{r1}a_3 = P_1 - \frac{m_1 \cdot a_3 \cdot l_6}{2l_1} - \frac{m_2 \cdot a_3 \cdot l_5}{2l_1} = 1183N$$

$$P_{r2}a_3 = P_2 + \frac{m_1 \cdot a_3 \cdot l_6}{2l_1} + \frac{m_2 \cdot a_3 \cdot l_5}{2l_1} = 5367N$$

$$P_{r3}a_3 = P_3 + \frac{m_1 \cdot a_3 \cdot l_6}{2l_1} + \frac{m_2 \cdot a_3 \cdot l_5}{2l_1} = 4452N$$

$$P_{r4}a_3 = P_4 - \frac{m_1 \cdot a_3 \cdot l_6}{2l_1} - \frac{m_2 \cdot a_3 \cdot l_5}{2l_1} = 268N$$

Lateral load  $P_{t1}a_3$

$$P_{t1}a_3 = -\frac{m_1 \cdot a_3 \cdot l_4}{2l_1} = -162N$$

$$P_{t2}a_3 = \frac{m_1 \cdot a_3 \cdot l_4}{2l_1} = 162N$$

$$P_{t3}a_3 = \frac{m_1 \cdot a_3 \cdot l_4}{2l_1} = 162N$$

$$P_{t4}a_3 = -\frac{m_1 \cdot a_3 \cdot l_4}{2l_1} = -162N$$

### Equivalent load calculation

At constant speed

$$P_{E1} = P_1 = 2562N$$

$$P_{E2} = P_2 = 3987N$$

$$P_{E3} = P_3 = 3073N$$

$$P_{E4} = P_4 = 1648N$$

When acceleration is toward left

$$P_{E1}a_3 = |P_{r1}a_3| + |P_{t1}a_3| = 2062N$$

$$P_{E2}a_3 = |P_{r2}a_3| + |P_{t2}a_3| = 8611N$$

$$P_{E3}a_3 = |P_{r3}a_3| + |P_{t3}a_3| = 7697N$$

$$P_{E4}a_3 = |P_{r4}a_3| + |P_{t4}a_3| = 2976N$$

# Linear Guide



## Linear Guide Selection

Conditions of Use	Equivalent load calculation
Model : LSH30HL2X2520S20BP-M6(2 pcs) Basic dynamic load rating : $C=45.7 KN$ Basic static load rating : $C_0=73.1 KN$ Mass $m_1=700kg$ $m_2=450kg$ Speed $V=0.75m/s$ Time $t_1=0.05s$ $t_2=1.9s$ $t_3=0.15s$ Acceleration $a_1=15m/s^2$ $a_3=5m/s^2$ Travel Distance $l_s=1500mm$ Distance $l_1=650mm$ $l_2=450mm$ $l_3=135mm$ $l_4=60mm$ $l_5=175mm$ $l_6=400mm$	When deceleration is toward left $P_{E1}la_3= P_1la_3 + Pt_1la_3 =4104N$ $P_{E2}la_3= P_2la_3 + Pt_2la_3 =2769N$ $P_{E3}la_3= P_3la_3 + Pt_3la_3 =1854N$ $P_{E4}la_3= P_4la_3 + Pt_4la_3 =3189N$ When acceleration is toward right $P_{E1}ra_3= P_1ra_3 + Pt_1ra_3 =7186N$ $P_{E2}ra_3= P_2ra_3 + Pt_2ra_3 =637N$ $P_{E3}ra_3= P_3ra_3 + Pt_3ra_3 =1551N$ $P_{E4}ra_3= P_4ra_3 + Pt_4ra_3 =6272N$ When deceleration is toward right $P_{E1}ra_3= P_1ra_3 + Pt_1ra_3 =1344N$ $P_{E2}ra_3= P_2ra_3 + Pt_2ra_3 =5529N$ $P_{E3}ra_3= P_3ra_3 + Pt_3ra_3 =4614N$ $P_{E4}ra_3= P_4ra_3 + Pt_4ra_3 =430N$
	<b>Calculation of static safety factor</b> We now know that the maximum equivalent load occurs on No.2 slider. Therefore, one can calculate static safety factor based on it in following formula $f_s = \frac{C_0}{P_{E2}la_1} = \frac{73.1 \times 10^3}{8611} = 8.49$
	<b>Calculation of the average load of each slider <math>P_{m_n}</math></b> $P_{m1} = \sqrt[3]{\frac{(P_{E1}la_1^3X_1 + P_{E1}^3X_2 + P_{E2}la_3^3X_3 + P_{E2}ra_3^3X_1 + P_{E2}^3X_2 + P_{E1}ra_3^3X_3)}{2l_s}}$ $= 2701N$ $P_{m2} = \sqrt[3]{\frac{(P_{E2}la_1^3X_1 + P_{E2}^3X_2 + P_{E2}la_3^3X_3 + P_{E2}ra_3^3X_1 + P_{E2}^3X_2 + P_{E2}ra_3^3X_3)}{2l_s}}$ $= 4077N$ $P_{m3} = \sqrt[3]{\frac{(P_{E3}la_1^3X_1 + P_{E3}^3X_2 + P_{E3}la_3^3X_3 + P_{E3}ra_3^3X_1 + P_{E3}^3X_2 + P_{E3}ra_3^3X_3)}{2l_s}}$ $= 3188N$ $P_{m4} = \sqrt[3]{\frac{(P_{E4}la_1^3X_1 + P_{E4}^3X_2 + P_{E4}la_3^3X_3 + P_{E4}ra_3^3X_1 + P_{E4}^3X_2 + P_{E4}ra_3^3X_3)}{2l_s}}$ $= 1873N$
	<b>Calculation of rated life <math>L_n</math></b> Assuming $f_n=1.5$ and according to rated life formula, the rated life can be calculated as follows: $L_1 = \left(\frac{C}{f_n P_{m1}}\right)^3 \times 50 = 71758Km$ $L_2 = \left(\frac{C}{f_n P_{m2}}\right)^3 \times 50 = 43641Km$ $L_3 = \left(\frac{C}{f_n P_{m3}}\right)^3 \times 50 = 20865Km$ $L_4 = \left(\frac{C}{f_n P_{m4}}\right)^3 \times 50 = 215195Km$
	<b>Calculation conclusion</b> Choose the minimum from four sliders to represent rated life, which is 20865 Km on No.2 slider

## Preload and rigidity

Preload spec can be applied to enhance rigidity. As the graph shows on the right, the effectiveness of preload can maintain until external load reaches 2.8 times of preload strength. In other words, rigidity increases 2.8 times. Preload is applied by choosing bigger diameter of rollers to increase interference between rollers and groove and raise initial loads. Therefore when calculating rated life, preload should be put into consideration.

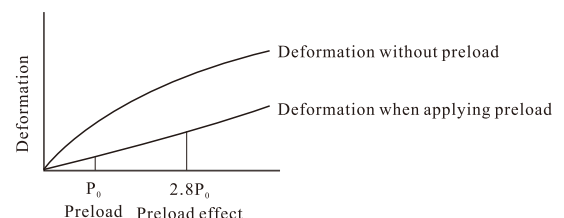



# LSD Series Low Profile Type Linear Guide

## Product Introduction

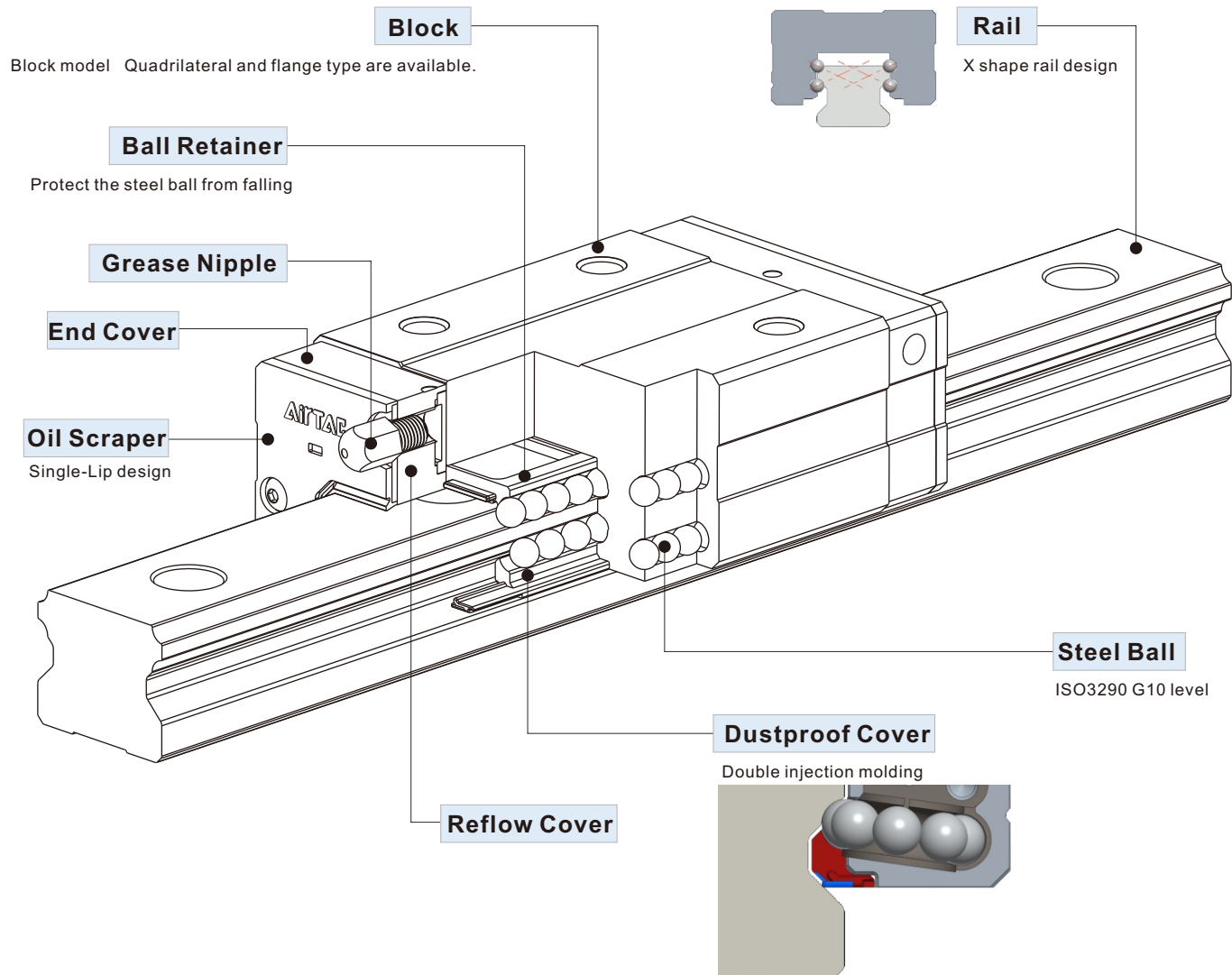

## Product Features

### 1. With self-adjustment ability

X-shaped ( $45^{\circ}$ - $45^{\circ}$ ) of curved groove on cross section design makes it self-aligning. Even small misalignment exists on the mounting surface, this design can help absorb it and maintain high precision, smooth and stable linear motion.

### 2. Low profile, High rigidity, equal load on four direction design

The  $45$ -degree contact angle design of the four rows of steel balls and the raceway allow the steel balls to achieve the ideal two-point contact, and can withstand the action and reaction force from the radial and lateral direction. Meanwhile, pre-load can be applied to increase extra rigidity if necessary. Reduce the combined height of the slide block and the slide rail, shorten the length of the slide block, to achieve miniaturization.

### 3. Interchangeable

Because of the strict control on manufacturing process, the dimensional accuracy is stable and within the set tolerance.

Besides, the ball retainer design can prevent steel balls from falling out. Therefore when assembling, blocks are interchangeable within the same spec and still maintain consistency of pre-load and accuracy.





# Low Profile Type Linear Guide



## LSD Series

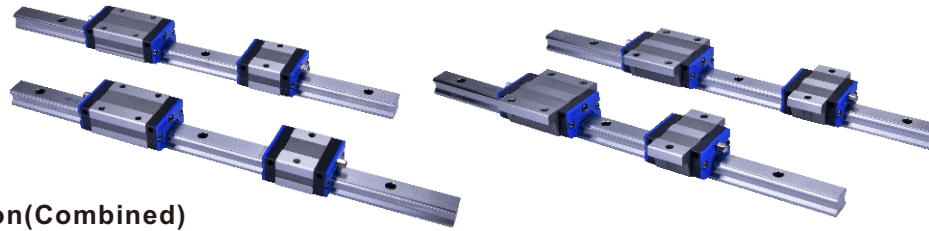







### Order Information(Combined)

#### 1.LSD15/30

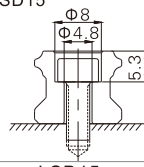
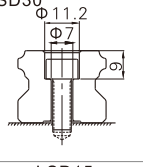
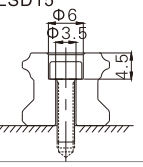
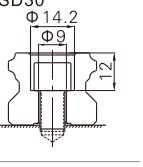
LSD 15 H N 1 X220 S20 A H - U - AM6 - B

① ② ③ ④ ⑤ ⑥ ⑦ ⑧ ⑨ ⑩ ⑪ ⑫

Standard margin pitch is 20mm.  
Customer can define a non-standard margin pitch.





① Model Code	LSD:Low Profile Type Linear Guide			
② Rail Width	15:15mm 30:28mm			
③ Block Style	H: Square type F1: Flange type, Mounting from top F2: Flange type, Mounting from bottom			
④ Block type	S: Short N: Standard			
⑤ Number of Block	1: One 2: Two [Note: Amount of block on a single set of linear guide]			
⑥ Length of Rail	220:220mm .....[Defined by customer]			
⑦ Position of first mounting hole	S□ : Distance from end of rail to the center of first mounting hole (It is recommended to be greater than minimum margin) [Standard margin pitch is 20mm]			
⑧ Preload	A: Standard clearance B: Light Preload C: Medium Preload			
⑨ Accuracy	N : Normal H : High P : Precision			
⑩ Rail type	LSD15:Blank: Top-mount(M4) LSD30:Blank: Top-mount(M6)		LSD15:U: Top-mount(M3) LSD30:U: Top-mount(M8)	
	 LSD15 Φ8 Φ4.8 Φ5 15	 LSD30 Φ11.2 Φ7 Φ8 30	 LSD15 Φ6 Φ3.5 Φ4 15	 LSD30 Φ14.2 Φ9 Φ10 30
⑪ Nipple/adaptor type	LSD15: M4: M4 Nipple	LSD15: AM6: M4 to M6 LSD30: A01: M6 to PT1/8 LSD30: AM8: M6 to M8	LSD15: LM6: M4 to M6 LSD30: L01: M6 to PT1/8 LSD30: LM8: M6 to M8	LSD30: SM6: M6 Nipple
	 M4  M6	 I type	 L type	 SM6
⑫ Packing type	Blank: the block and rail are assembled B: block and rail are put separately			

#### 2.LSD20/25/35

LSD 20 H N 1 X220 S20 A H - AM8 - B

① ② ③ ④ ⑤ ⑥ ⑦ ⑧ ⑨ ⑩ ⑪

Standard margin pitch is 20mm.  
Customer can define a non-standard margin pitch.

① Model Code	LSD:Low Profile Type Linear Guide			
② Rail Width	20:20mm 25:23mm 35:34mm			
③ Block Style	H: Square type F1: Flange type, Mounting from top F2: Flange type, Mounting from bottom			
④ Block type	S: Short N: Standard			
⑤ Number of Block	1: One 2: Two [Note: Amount of block on a single set of linear guide]			
⑥ Length of Rail	220:220mm .....[Defined by customer]			
⑦ Position of first mounting hole	S□ : Distance from end of rail to the center of first mounting hole (It is recommended to be greater than minimum margin) [Standard margin pitch is 20mm]			
⑧ Preload	A: Standard clearance B: Light Preload C: Medium Preload			
⑨ Accuracy	N : Normal H : High P : Precision			
⑩ Nipple/adaptor type	M6:M6 Nipple	A01:M6 to PT1/8 AM8:M6 to M8	L01:M6 to PT1/8 LM8:M6 to M8	SM6: M6 Nipple
	 M6	 I type	 L type	 SM6
⑪ Packing type	Blank: the block and rail are assembled B: block and rail are put separately			



# Low Profile Type Linear Guide



## LSD Series

### Butt-jointed Order Information

#### 1.LSD15/30

LSD 15 H N 1 X3920 T 3900 T 3920 A H-U-AM6-B

① ② ③ ④ ⑤ ⑥ ⑦ ⑧ ⑨ ⑩ ⑪ ⑫ ⑬ ⑭ ⑮

Note: Number of joints cannot be more than 2 times(three rails at most).  
For LSD15, maximum length of jointed rail is 11800mm. For LSD30, it's 11880.  
Customization is needed for joint times more than standard.

Butt-jointed end margin: 1/2P,  
Position of the first and last  
hole is defined by customer.

① Model Code	LSD:Low Profile Type Linear Guide			
② Rail Width	15:15mm 30:28mm			
③ Block Style	H: Square type F1: Flange type, Mounting from top F2: Flange type, Mounting from bottom			
④ Block type	S: Short N: Standard			
⑤ Number of Block	1: One 2: Two [Note: Amount of block on a single set of linear guide]			
⑥ Length of first Rail	3920:3920mm .....[Defined by customer]			
⑦ Butt-jointed mark	T: Rail Butt-jointed mark(Butt-jointed end margin:1/2P) [P is the standard hole distance]			
⑧ Length of second Rail	3900:3900mm .....[Defined by customer]			
⑨ Butt-jointed mark	Blank: two rails joint T: Rail Butt-jointed mark (Butt-jointed end margin:1/2P) [P is the standard hole distance]			
⑩ Length of third Rail	Blank: two rails joint 3920:3920mm..[Defined by the customer]			
⑪ Preload	A: Standard clearance B: Light Preload C: Medium Preload			
⑫ Accuracy	N : Normal H : High P : Precision			
⑬ Rail type	LSD15:Blank: Top-mount(M4)	LSD15:U: Top-mount(M3)		
	LSD30:Blank: Top-mount(M6)	LSD30:U: Top-mount(M8)		
⑭ Nipple/adaptor type	LSD15: M4: M4 Nipple	LSD15: AM6: M4 to M6	LSD15: LM6: M4 to M6	LSD30: SM6: M6 Nipple
	LSD30: M6: M6 Nipple	LSD30: A01: M6 to PT1/8 LSD30: AM8: M6 to M8	LSD30: L01: M6 to PT1/8 LSD30: LM8: M6 to M8	
⑮ Packing type	Blank: the block and rail are assembled B: block and rail are put separately			

#### 2.LSD20/25/35

LSD 20 H N 1 X3920 T 3900 T 3920 A H-AM8-B

① ② ③ ④ ⑤ ⑥ ⑦ ⑧ ⑨ ⑩ ⑪ ⑫ ⑬ ⑭

Note: Number of joints cannot be more than 2 times(three rails at most).  
For LSD20/25, maximum length of jointed rail is 11800mm. For LSD35, it's 11880.  
Customization is needed for joint times more than standard.

Butt-jointed end margin: 1/2P,  
Position of the first and last  
hole is defined by customer.

① Model Code	LSD:Low Profile Type Linear Guide			
② Rail Width	20:20mm 25:23mm 35:34mm			
③ Block Style	H: Square type F1: Flange type, Mounting from top F2: Flange type, Mounting from bottom			
④ Block type	S: Short N: Standard			
⑤ Number of Block	1: One 2: Two [Note: Amount of block on a single set of linear guide]			
⑥ Length of first Rail	3920:3920mm .....[Defined by customer]			
⑦ Butt-jointed mark	T: Rail Butt-jointed mark (Butt-jointed end margin:1/2P) [P is the standard hole distance]			
⑧ Length of second Rail	3900:3900mm .....[Defined by customer]			
⑨ Butt-jointed mark	Blank: two rails joint T: Rail Butt-jointed mark (Butt-jointed end margin:1/2P) [P is the standard hole distance]			
⑩ Length of third Rail	Blank: two rails joint 3920:3920mm..[Defined by the customer]			
⑪ Preload	A: Standard clearance B: Light Preload C: Medium Preload			
⑫ Accuracy	N : Normal H : High P : Precision			
⑬ Nipple/adaptor type	M6: M6 Nipple	A01: M6 to PT1/8 AM8: M6 to M8	L01: M6 to PT1/8 LM8: M6 to M8	SM6: M6 Nipple
		I type	L type	
⑭ Packing type	Blank: the block and rail are assembled B: block and rail are put separately			



# Low Profile Type Linear Guide



## LSD Series

### 1. Block Order Information

#### LSD 15 BK - H N - H - E - AM6



Notes: When selecting rails and bearings, the different pairing codes can change the units preload, details see "preload pairing chart".

① Model Code	LSD:Low Profile Type Linear Guide							
② Rail Width	15:15mm	20:20mm	25:23mm	30:28mm	35:34mm			
③ Block Code	BK: Block							
④ Block Style	H: Square type		F1: Flange type, Mounting from top F2: Flange type, Mounting from bottom					
⑤ Block type	S: Short		N: Standard					
⑥ Accuracy	N: Normal		H: High					
⑦ Group code	SA		C		E [Note]			
⑧ Nipple /adapter type	15	M4	M4 Nipple		20 25 30 35	M6	M6 Nipple	
		AM6	M4 to M6	I type		A01	M6 to PT1/8	I type
		LM6	M4 to M6	L type		L01	M6 to PT1/8	L type
						LM8	M6 to M8	
						SM6	M6 Nipple	

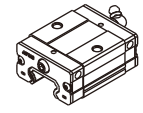

S: Short

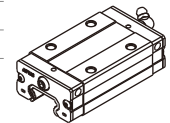

N: Standard

### 2. Rail(4m) Order Information

#### (1) LSD15/30

#### LSD 15 RL X 4000 - H - E - U



① Model Code	LSD:Low Profile Type Linear Guide			
② Rail Width	15:15mm 30:28mm			
③ Rail Code	RL: Rail			
④ Rail Length	4000 : 4000mm			
⑤ Accuracy	N : Normal		H : High	
⑥ Group code	E [Note]			
⑦ Rail type	LSD15:Blank: Top-mount(M4)		LSD15:U: Top-mount(M3)	
	LSD30:Blank: Top-mount(M6)		LSD30:U: Top-mount(M8)	
	LSD15	LSD30	LSD15	LSD30

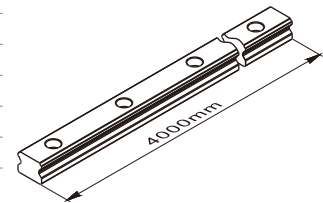

Note: ●Standard length of LSD rail is four meters.

●For LSD15, both margin pitch of rail are 20mm. For LSD30, one side of margin pitch is 20mm, the other side is 60mm.

●When selecting rails and bearings, the different pairing codes can change the units preload, details see "preload pairing chart".

#### (2) LSD20/25/35

#### LSD 20 RL X 4000 - H - E



① Model Code	LSD:Low Profile Type Linear Guide		
② Rail Width	20:20mm	25:23mm	35:34mm
③ Rail Code	RL: Rail		
④ Rail Length	4000 : 4000mm		
⑤ Accuracy	N : Normal		H : High
⑥ Group Code	E [Note]		

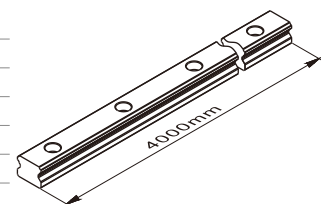

Note: ●Standard length of LSD rail is four meters.

●For LSD20/25, both margin pitch of rail are 20mm.

●For LSD35, one side of margin pitch is 20mm, the other side is 60mm.

●When selecting rails and bearings, the different pairing codes can change the units preload, details see "preload pairing chart".





# Low Profile Type Linear Guide



## LSD Series

### 3. Rail Order Information

#### (1) LSD15/30

LSD 15 RL X 220-S20 - H - E - U



① Model Code	LSD:Low Profile Type Linear Guide	
② Rail Width	15:15mm 30:28mm	
③ Rail Code	RL: Rail	
④ Rail Length	220:220mm .....[Defined by customer]	
⑤ Position of first mounting hole	S□ : Distance from end of rail to the center of first mounting hole (It is recommended to be greater than minimum margin) [Standard margin pitch is 20mm]	
⑥ Accuracy	N : Normal H : High	
⑦ Group code	E [Note]	
⑧ Rail type	LSD15:Blank: Top-mount(M4)	LSD15:U: Top-mount(M3)
	LSD30:Blank: Top-mount(M6)	LSD30:U: Top-mount(M8)
	LSD15	LSD30

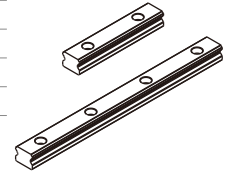

Standard margin pitch is 20mm.  
Customer can define a non-standard margin pitch.

Note:When selecting rails and bearings, the different pairing codes can change the units preload, details see "preload pairing chart".

#### (2) LSD20/25/35

LSD 20 RL X 220 - S20 - H - E



① Model Code	LSD:Low Profile Type Linear Guide	
② Rail Width	20:20mm 25:23mm 35:34mm	
③ Rail Code	RL: Rail	
④ Rail Length	220:220mm .....[Defined by customer]	
⑤ Position of first mounting hole	S□ : Distance from end of rail to the center of first mounting hole (It is recommended to be greater than minimum margin) [Standard margin pitch is 20mm]	
⑥ Accuracy	N : Normal H : High	
⑦ Group code	E [Note]	

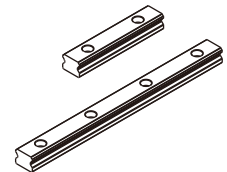

Standard margin pitch is 20mm.  
Customer can define a non-standard margin pitch.

Note:When selecting rails and bearings, the different pairing codes can change the units preload, details see "preload pairing chart".

### 4. Rail/Block preload pairing chart

When customer orders rail/block, please choose the pairing code of rail/block in accordance with the needed preload of linear guide(combined). Details please refer to the "preload pairing chart".

Preload pairing chart		
Preload grade	Rail pairing code	
	E	
Block pairing code	SA	Medium preload
	C	Light preload
	E	Standard clearance



# Low Profile Type Linear Guide



## LSD Series

### Accessory Order Code

L - P - AM6



① Accessory Code		L: Linear Guide Accessory						
② Nipple/adaptor Code		P: Nipple/adaptor						
③ Nipple/adaptor type	15	M4	M4 Nipple					
		AM6	M4 to M6	I type				
		LM6	M4 to M6	L type				
					20	M6	M6 Nipple	
					25	A01	M6 to PT1/8	I type
				30	AM8	M6 to M8		
				35	L01	M6 to PT1/8	L type	
					LM8	M6 to M8		
					SM6	M6 Nipple		

### Rail Specification

The edge pitch of first mounting hole (S) and last mounting hole (E) should not be greater than 1/2P.  
Overlong edge may induce unstable installation and affect the accuracy.  
n: Numbers of mounting holes

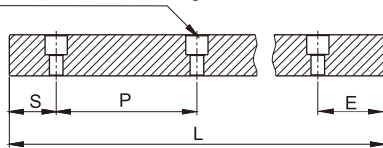

$$L = (n-1) \times P + S + E$$

L: Total length of rail (mm)  
n: Numbers of mounting holes on rail  
P: Distance between bolt holes (mm)  
S: Edge of first mounting hole (mm)  
E: Edge of last mounting hole (mm)

Model	LSD15	LSD20	LSD25	LSD30	LSD35
Pitch(P)	60	60	60	80	80
Standard Edge pitch(S)	20	20	20	20	20
Min. Edge Pitch(S/E min)	5(4)	6	7	7(8)	8
Max. Edge Pitch(S/E max)	55(56)	54	53	73(72)	72
Maximum length of rail for standard edge	4000	4000	4000	3960	3960
Maximum length(Lmax)	4000	4000	4000	4000	4000

Note:

- For LSD15 when it mounted with M3 screw, Min. edge pitch is 4mm. Max. edge pitch is 56mm.  
For LSD15 when it mounted with M4 screw, Min. edge pitch is 5mm. Max. edge pitch is 55mm.
- For LSD30 when it mounted with M6 screw, Min. edge pitch is 7mm. Max. edge pitch is 79mm.  
For LSD15 when it mounted with M8 screw, Min. edge pitch is 8mm. Max. edge pitch is 72mm.
- Joint rail must be chosen if length of rail exceeds the maximum.
- When deciding edge pitch, it should be within the range of above table.  
There would be risk of broken hole if pitch is out of range.
- Maximum length of rail for standard' means the maximum length of rail can be chosen when both sides of edge pitches are standard.

### Specifications and Dimensions

#### Square type

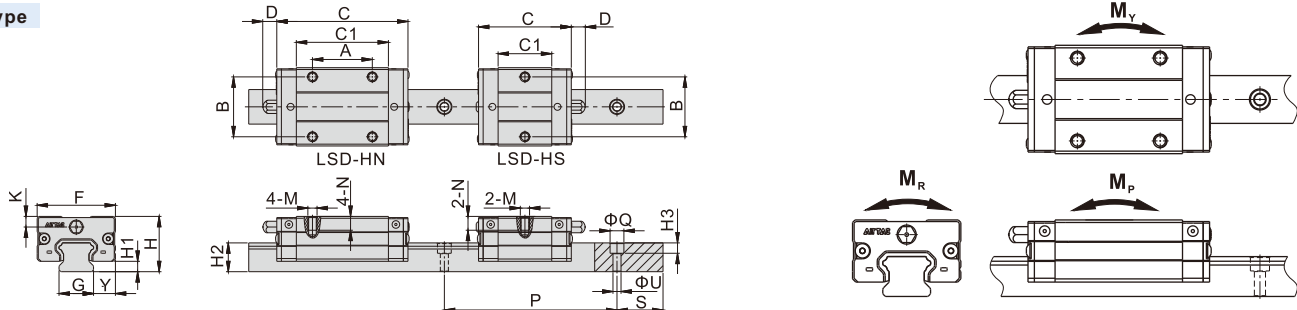

Model/Item	External Dimension(mm)					Block Dimension(mm)					Rail Dimension(mm)								
	H	H1	F	Y	C	C1	A	B	K	D	M	N	G	H2	P	S	ΦQ[Note]	H3	
LSD15HS	24	4.5	34	9.5	40.5	23.5	-	26	4.6	6	M4X0.7	6	15	12.5	60	20	8(6)	4.8(3.5)	5.3(4.5)
LSD15HN	24	4.5	34	9.5	57	40	26	26	4.6	6	M4X0.7	6	15	12.5	60	20	8(6)	4.8(3.5)	5.3(4.5)
LSD20HS	28	6	42	11	46	29	-	32	6.2	13	M5X0.8	7	20	15.5	60	20	9.5	5.8	8.5
LSD20HN	28	6	42	11	65	48	32	32	6.2	13	M5X0.8	7	20	15.5	60	20	9.5	5.8	8.5
LSD25HS	33	7	48	12.5	59	36.5	-	35	7.2	13	M6X1.0	9	23	18	60	20	11.2	7	9
LSD25HN	33	7	48	12.5	83	60.5	35	35	7.2	13	M6X1.0	9	23	18	60	20	11.2	7	9
LSD30HS	42	9	60	16	68.5	41.5	-	40	7.2	13	M8X1.25	12	28	23	80	20	11.2(14.2)	7(9)	9(12)
LSD30HN	42	9	60	16	97	70	40	40	7.2	13	M8X1.25	12	28	23	80	20	11.2(14.2)	7(9)	9(12)
LSD35HS	48	11	70	18	73.5	46.5	-	50	8.5	13	M8X1.25	12	34	27.5	80	20	14.2	9	12
LSD35HN	48	11	70	18	106.5	79.5	50	50	8.5	13	M8X1.25	12	34	27.5	80	20	14.2	9	12

Model/Item	Mounting Screw	Dynamic Load Rating(kN)	Static Load Rating(kN)	Static Rated Moment (kN.m)			Weight	
				M <sub>z</sub>	M <sub>y</sub>	M <sub>x</sub>	Block(kg)	Rail(kg/m)
LSD15HS	M4(M3)	5.0	9.5	0.07	0.04	0.04	0.09	1.23
LSD15HN	M4(M3)	8.9	16.5	0.12	0.10	0.10	0.15	1.23
LSD20HS	M5	7.2	13.5	0.13	0.06	0.06	0.14	2.11
LSD20HN	M5	12.1	22.4	0.20	0.15	0.15	0.23	2.11
LSD25HS	M6	11.5	20.8	0.22	0.11	0.11	0.26	2.76
LSD25HN	M6	19.3	34.7	0.36	0.31	0.31	0.42	2.76
LSD30HS	M6(M8)	19.8	30.0	0.38	0.20	0.20	0.44	4.60
LSD30HN	M6(M8)	28.3	50.3	0.65	0.53	0.53	0.75	4.60
LSD35HS	M8	29.2	40.7	0.66	0.33	0.33	0.74	6.27
LSD35HN	M8	42.7	70.2	1.02	0.72	0.72	1.17	6.27

[Note]: The standard countersink of LSD15 rail is Φ8X5.3XΦ4.8 and with M4 screw. If with M3 screw, the ordering code should add "U", and the countersink is Φ6X4.5XΦ3.5. The standard countersink of LSD30 rail is Φ11.2X9XΦ7 and with M6 screw. If with M8 screw, the ordering code should add "U", and the countersink is Φ14.2X12XΦ9.



# Low Profile Type Linear Guide



## LSD Series

### Flange type, Top-Mount

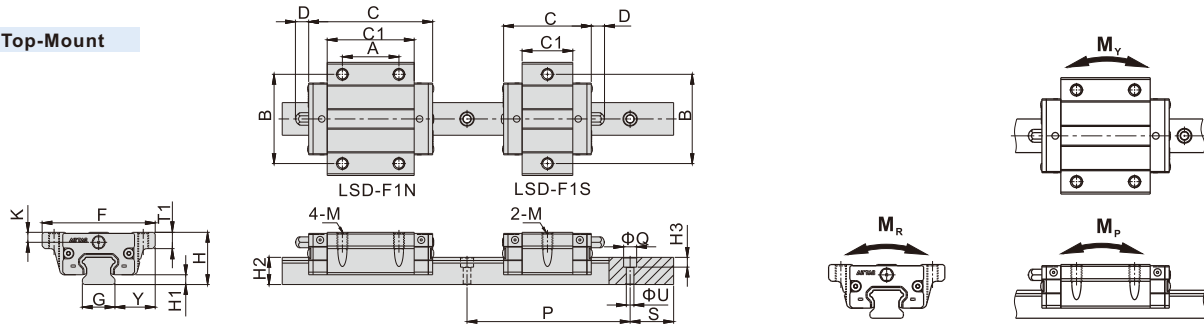

Model/Item	External Dimension (mm)					Block Dimension (mm)							Rail Dimension (mm)						
	H	H1	F	Y	C	C1	A	B	K	D	M	T1	G	H2	P	S	ΦQ[Note]	ΦU	H3
LSD15F1S	24	4.5	52	18.5	40.5	23.5	-	41	4.6	6	M5X0.8	7.5	15	12.5	60	20	8(6)	4.8(3.5)	5.3(4.5)
LSD15F1N	24	4.5	52	18.5	57	40	26	41	4.6	6	M5X0.8	7.5	15	12.5	60	20	8(6)	4.8(3.5)	5.3(4.5)
LSD20F1S	28	6	59	19.5	46	29	-	49	6.2	13	M6X1.0	9.5	20	15.5	60	20	9.5	5.8	8.5
LSD20F1N	28	6	59	19.5	65	48	32	49	6.2	13	M6X1.0	9.5	20	15.5	60	20	9.5	5.8	8.5
LSD25F1S	33	7	73	25	59	36.5	-	60	7.2	13	M8X1.25	10.5	23	18	60	20	11.2	7	9
LSD25F1N	33	7	73	25	83	60.5	35	60	7.2	13	M8X1.25	10.5	23	18	60	20	11.2	7	9
LSD30F1S	42	9	90	31	68.5	41.5	-	72	7.2	13	M10X1.5	10.5	28	23	80	20	11.2(14.2)	7(9)	9(12)
LSD30F1N	42	9	90	31	97	70	40	72	7.2	13	M10X1.5	10.5	28	23	80	20	11.2(14.2)	7(9)	9(12)
LSD35F1S	48	11	100	33	73.5	46.5	-	82	8.5	13	M10X1.5	13.5	34	27.5	80	20	14.2	9	12
LSD35F1N	48	11	100	33	106.5	79.5	50	82	8.5	13	M10X1.5	13.5	34	27.5	80	20	14.2	9	12

Model/Item	Mounting Screw	Dynamic Load Rating(kN)	Static Load Rating(kN)	Static Rated Moment (kN.m)			Weight	
				Mr	Mp	My	Block(kg)	Rail(kg/m)
LSD15F1S	M4(M3)	5.0	9.5	0.07	0.04	0.04	0.12	1.23
LSD15F1N	M4(M3)	8.9	16.5	0.12	0.10	0.10	0.21	1.23
LSD20F1S	M5	7.2	13.5	0.13	0.06	0.06	0.18	2.11
LSD20F1N	M5	12.1	22.4	0.20	0.15	0.15	0.31	2.11
LSD25F1S	M6	11.5	20.8	0.22	0.11	0.11	0.36	2.76
LSD25F1N	M6	19.3	34.7	0.36	0.31	0.31	0.60	2.76
LSD30F1S	M6(M8)	19.8	30.0	0.38	0.20	0.20	0.61	4.60
LSD30F1N	M6(M8)	28.3	50.3	0.65	0.53	0.53	1.03	4.60
LSD35F1S	M8	29.2	40.7	0.66	0.33	0.33	0.93	6.27
LSD35F1N	M8	42.7	70.2	1.02	0.72	0.72	1.50	6.27

[Note]: The standard countersink of LSD15 rail is  $\Phi 8 \times 5.3 \times \Phi 4.8$  and with M4 screw. If with M3 screw, the ordering code should add "U", and the countersink is  $\Phi 6 \times 4.5 \times \Phi 3.5$ . The standard countersink of LSD30 rail is  $\Phi 11.2 \times 9 \times \Phi 7$  and with M6 screw. If with M8 screw, the ordering code should add "U", and the countersink is  $\Phi 14.2 \times 12 \times \Phi 9$ .

### Flange type, Bottom-Mount

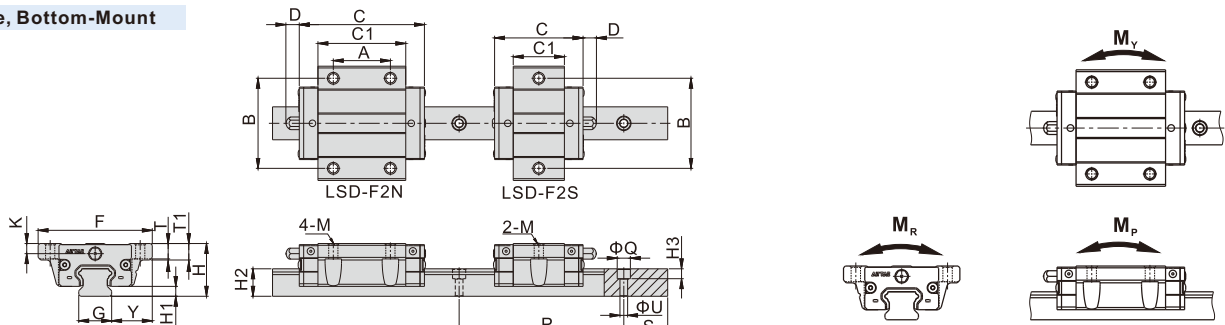

Model/Item	External Dimension(mm)					Block Dimension(mm)							Rail DimensionZ(mm)							
	H	H1	F	Y	C	C1	A	B	K	D	M	T	T1	G	H2	P	S	ΦQ[Note]	ΦU	H3
LSD15F2S	24	4.5	52	18.5	40.5	23.5	-	41	4.6	6	$\Phi 4.5$	7	7.5	15	12.5	60	20	8(6)	4.8(3.5)	5.3(4.5)
LSD15F2N	24	4.5	52	18.5	57	40	26	41	4.6	6	$\Phi 4.5$	7	7.5	15	12.5	60	20	8(6)	4.8(3.5)	5.3(4.5)
LSD20F2S	28	6	59	19.5	46	29	-	49	6.2	13	$\Phi 5.7$	9	9.5	20	15.5	60	20	9.5	5.8	8.5
LSD20F2N	28	6	59	19.5	65	48	32	49	6.2	13	$\Phi 5.7$	9	9.5	20	15.5	60	20	9.5	5.8	8.5
LSD25F2S	33	7	73	25	59	36.5	-	60	7.2	13	$\Phi 6.8$	10	10.5	23	18	60	20	11.2	7	9
LSD25F2N	33	7	73	25	83	60.5	35	60	7.2	13	$\Phi 6.8$	10	10.5	23	18	60	20	11.2	7	9
LSD30F2S	42	9	90	31	68.5	41.5	-	72	7.2	13	$\Phi 9$	10	10.5	28	23	80	20	11.2(14.2)	7(9)	9(12)
LSD30F2N	42	9	90	31	97	70	40	72	7.2	13	$\Phi 9$	10	10.5	28	23	80	20	11.2(14.2)	7(9)	9(12)
LSD35F2S	48	11	100	33	73.5	46.5	-	82	8.5	13	$\Phi 9$	13	13.5	34	27.5	80	20	14.2	9	12
LSD35F2N	48	11	100	33	106.5	79.5	50	82	8.5	13	$\Phi 9$	13	13.5	34	27.5	80	20	14.2	9	12

Model/Item	Mounting Screw	Dynamic Load Rating(kN)	Static Load Rating(kN)	Static Rated Moment (kN.m)			Weight	
				Mr	Mp	My	Block(kg)	Rail(kg/m)
LSD15F2S	M4(M3)	5.0	9.5	0.07	0.04	0.04	0.12	1.23
LSD15F2N	M4(M3)	8.9	16.5	0.12	0.10	0.10	0.21	1.23
LSD20F2S	M5	7.2	13.5	0.13	0.06	0.06	0.18	2.11
LSD20F2N	M5	12.1	22.4	0.20	0.15	0.15	0.31	2.11
LSD25F2S	M6	11.5	20.8	0.22	0.11	0.11	0.36	2.76
LSD25F2N	M6	19.3	34.7	0.36	0.31	0.31	0.60	2.76
LSD30F2S	M6(M8)	19.8	30.0	0.38	0.20	0.20	0.61	4.60
LSD30F2N	M6(M8)	28.3	50.3	0.65	0.53	0.53	1.03	4.60
LSD35F2S	M8	29.2	40.7	0.66	0.33	0.33	0.93	6.27
LSD35F2N	M8	42.7	70.2	1.02	0.72	0.72	1.50	6.27

[Note]: The standard countersink of LSD15 rail is  $\Phi 8 \times 5.3 \times \Phi 4.8$  and with M4 screw. If with M3 screw, the ordering code should add "U", and the countersink is  $\Phi 6 \times 4.5 \times \Phi 3.5$ . The standard countersink of LSD30 rail is  $\Phi 11.2 \times 9 \times \Phi 7$  and with M6 screw. If with M8 screw, the ordering code should add "U", and the countersink is  $\Phi 14.2 \times 12 \times \Phi 9$ .



# Low Profile Type Linear Guide



## LSD Series

### Accuracy Classes

LSD Low Profile type linear guide comes with 3 accuracy levels.

Table 1: Parallelism of the raceway

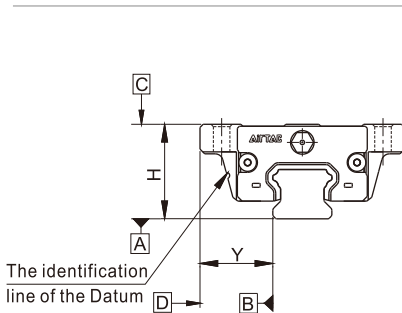

Accuracy	Accuracy Standards (mm)					
	N : Normal		H: High		P: Precision	
Model	15/20	25/30/35	15/20	25/30/35	15/20	25/30/35
Tolerance of height H	±0.1		±0.03	±0.04	±0.015	±0.02
Variation of height ΔH	0.02	0.025	0.01	0.015	0.006	0.007
Tolerance of width Y	±0.1		±0.03	±0.04	±0.015	±0.02
Variation of width ΔY	0.02	0.03	0.01	0.015	0.006	0.007
Parallelism of C-surface relative to A-surface	Parallelism of raceway (Refer to Table 1)					
Parallelism of D-surface relative to B-surface	Parallelism of raceway (Refer to Table 1)					

Accuracy Rail Length(mm)	Parallelism of the raceway(μm)		
	N	H	P
100 under	12	7	3
100~200	14	9	4
200~300	15	10	5
300~500	17	12	6
500~700	20	13	7
700~900	22	15	8
900~1100	24	16	9
1100~1500	26	18	11
1500~1900	28	20	13
1900~2500	31	22	15
2500~3100	33	25	18
3100~3600	36	27	20
3600~4000	37	28	21

### Preload Level

#### 1. Preload interference

The LSD Low Profile type Linear Guide has three preload categories: A, B and C.

Choosing suitable preload level will enhance rigidity, precision and torsion resistant performance of the linear guide.

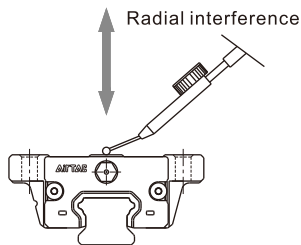

Model	Radial interference(μm)		
	Standard clearance(A)	Light Preload(B)	Middle Preload(C)
LSD15	-4 2	-12~-4	-22 -14
LSD20	-5 2	-13~-5	-23 -15
LSD25	-6 2	-14~-6	-24 -16
LSD30	-7 2	-16~-7	-26 -17
LSD35	-8 2	-18~-8	-28 -18

#### 2. Common Application

Refer to following table for suitable application of different preload grade:

Preload grade	Requirement	Common Application
Standard clearance(A)	One axial movement, small vibration and impact, accuracy requirement is low	Conveyor Machine, Semiconductor Equipment, Stage Equipment, Press Machine, Welding Machine and other light movement equipments
Light Preload(B)	Equipment that requires light-load and high-precision.	Z-axis movement for industrial use, NC lathe, EDM, Precision XY platform, Vertical machine center, measurement instrument, material feeder or industrial robot
Medium Preload(C)	Equipment that requires high rigidity, large vibration and shock.	Machining centers, NC lathes, grinders, vertical or horizontal milling machines, boring machines, tool guides, heavy cutting machines.



# Low Profile Type Linear Guide

## LSD Series

### Installation Illustration

#### 1. Allowable tolerance of mounting surface

LSD series is an arc-shape, two-point contact design of linear guide. Its self-centering feature allows some tolerance on mounting surface without affecting the smoothness of linear motion. The allowable tolerance is indicated in following table:

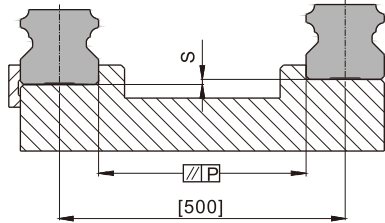

Model	Allowable tolerance of parallelism P(μm)			Allowable tolerance of top and bottom S(μm)		
	Standard clearance(A)	Light Preload(B)	Medium Preload(C)	Standard clearance(A)	Light Preload(B)	Medium Preload(C)
LSD15	25	18	-	130	85	-
LSD20	25	20	18	130	85	50
LSD25	30	22	20	130	85	70
LSD30	40	30	27	170	110	90
LSD35	50	35	30	210	150	120

Note: The value in the table is the allowable value when the distance between the two linear guides is 500mm, and the allowable value is proportional to the distance between the two linear guides.

#### 2. Height and Chamfer of Reference Edge

In order to ensure accurate installation of LSD Linear Guide, the contact space should not exceed the given figures in following table.

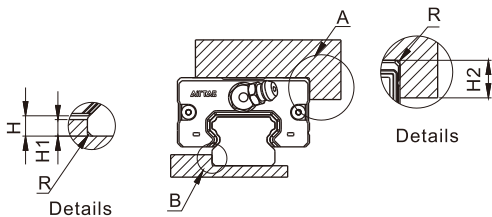

Model	Unit mm			
	H	H1	H2	R(Max)
LSD15	4.5	2.7	5	0.5
LSD20	6	5	7	0.5
LSD25	7	5	7.5	1
LSD30	9	7	7	1
LSD35	11	7.5	9.5	1

#### 3. Screw Tighten Torque

When installing linear guide, whether the screws are well tighten and surface is well contacted will affect accuracy significantly. Please refer to following table for tightening force to ensure a perfect installation.

Model	Screw size	Tighten Torque(N.cm)		
		Iron	Casting	Aluminum alloy
LSD15	M3	196	127	98
	M4	412	274	206
LSD20	M5	882	588	441
LSD25	M6	1370	921	686
LSD30	M6	1370	921	686
	M8	3040	2010	1470
LSD35	M8	3040	2010	1470

#### 4. Datum plane

- Datum plane for installation must be ground or finely milled to ensure accuracy.
- Both sides of Rail can be used as the datum plane.
- For multi-blocks on a rail, identification line on blocks should be put on the same side to ensure moving accuracy.

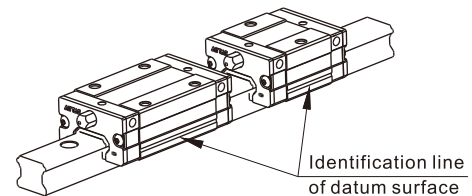

### Rail Butt-jointed

- When jointing rails, it must follow group marks on rail to ensure the accuracy of linear guide. These marks are located on the top surface at joint side. Please put the same group marks together.

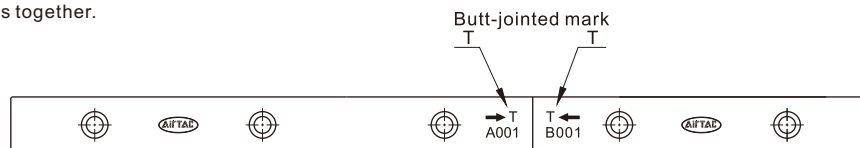

- Be aware serial number of group mark when assemble. A001 and B001 are in a group, so as to A002 and B002 and so on.
- Be aware the installation direction while assembly, the serial numbers are not upside down and arrows point to each other.

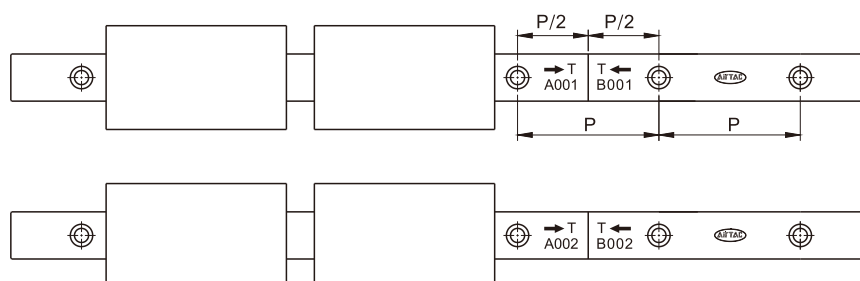



# Low Profile Type Linear Guide

## LSD Series

### Lubrication method

When a linear guide is well lubricated, it can reduce wear and increase lifespan significantly. Lubrication has the following benefits :

- Reduces friction of the rollers and raceway to minimize wear.
- The grease film between contact surface can prevent roller fatigue.
- Prevent rust.

#### 1. Lubrication Grease

Use the correct grade of lubrication. While lubricating, a grease gun can be used to pump grease into slider through the grease nipple on it. The suitable condition for lube is when working speed is under 60 m/min and not in cooling process.

#### ● Nipple type

	L-P-M4	L-P-M6	L-P-SM6
Grease nipple type			

#### ● Grease amount

LSD series linear guide is well lubricated with 'Shell Alvania grease S2' in factory. Customers are recommended to use identical or the same grade of lubricant. After lubrication, block needs to be moved back and forth at least three times for the length of three blocks and repeat at least twice. Check if the surface of rail is well covered by grease film.

Model	Grease amount for the first lubrication (cm <sup>3</sup> )		Replenishment amount (cm <sup>3</sup> )	
	Short type	Standard type	Short type	Standard type
LSD15	0.5	0.9	0.2	0.3
LSD20	1.1	1.8	0.4	0.6
LSD25	1.8	3.2	0.6	1.0
LSD30	2.9	4.5	0.9	1.4
LSD35	4.1	5.9	1.3	1.8

#### ● Lubrication frequency

Although the linear guides are well lubricated at factory and retains grease well, frequent lubrication is still necessary to avoid undesirable wear. Recommended lubrication period is every 100km of movement or every 3~6 months. (Refer to table on the top for suggested amount)

#### 2. Lubricating oil

Recommended oil viscosity for lubrication use is about 30 to 150 cst.

Lubrication oil is suitable for all kinds of load and impact application, but not for high temperature use due to its tendency of vaporization.

#### ● Adaptor

L-P-AM6	L-P-AM8	L-P-A01
<p>LSD15</p>	<p>LSD35 LSD30 LSD25 LSD20</p>	<p>LSD35 LSD30 LSD25 LSD20</p>
L-P-LM6	L-P-LM8	L-P-L01
<p>LSD15</p>	<p>LSD35 LSD30 LSD25 LSD20</p>	<p>LSD35 LSD30 LSD25 LSD20</p>

Note: After installation, the top surface of adaptor may be higher than block. Be careful about the interference while moving.

# Low Profile Type Linear Guide

## LSD Series

### Lubrication method

#### ●Oil supply rate

Loss of lubrication oil is faster than lubrication grease. Pay attention to sufficiency of oil while using.

Model	Oil amount for the first lubrication(cm <sup>3</sup> )	Feeding Speed(cm <sup>3</sup> /hr)
LSD15	0.3	0.1
LSD20	0.5	0.15
LSD25	0.6	0.2
LSD30	0.8	0.25
LSD35	0.9	0.3

### 3. Grease nipple/adaptor installation

- Grease nipple or adaptor can be installed in the two sides of block for manual or automatic lubrication based on customer's requirement.
- There are a secondary set of lubricating ports on the side of the block. When using, it is not recommended to use the side with datum line unless necessary.
- Lateral nipple installation is not recommended for flange type blocks.  
(The grease / oil nipple may interfere with block)
- If lateral lubrication is needed for above spec, please contact us for customization.

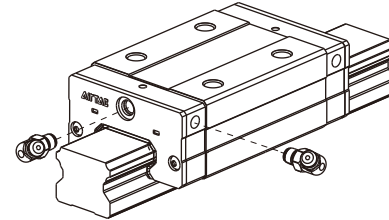

## Bolt hole plug

### 1. Plug type

In order to prevent metal swarf or external objects from entering blocks and affecting precision and lifespan, customers must put plugs into holes during installation. Every rail is equipped with default plugs.

Model	Bolt	Diameter(D)(mm)	Thickness(H)(mm)
LSD15	M3	6.15	1.2
	M4	8.15	1.1
LSD20	M5	9.65	2.5
LSD25	M6	11.4	2.5
LSD30	M6	11.4	2.5
	M8	14.4	3.5
LSD35	M8	14.4	3.5

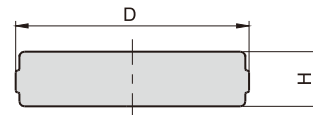

### 2. Plug installation Steps

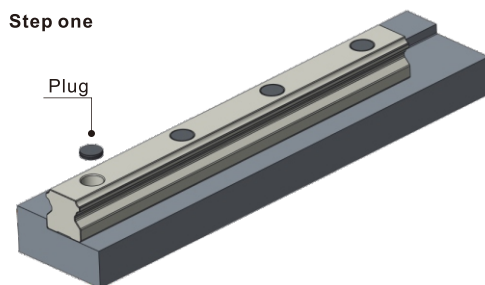

Place the plug in counterbore.

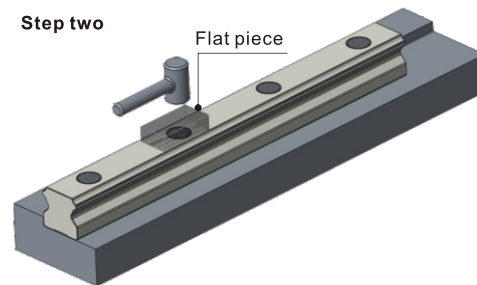

Place the flat piece on mounting hole, hit the piece vertically with a plastic hammer and fix the plug into counterbore.

Note:

- Please make sure the plugs do not protrude the rail surface.
- After installation, please clean the surface before use.

# Low Profile Type Linear Guide

## LSD Series

### Precautions on use

#### 1. Block disassembly

With ball retainers and a dustproof cover, normally the balls are prevented from falling out when block is removed from rail.

However, if obliquely insert rail into blocks or quickly assembled or disassembled, there is a risk for balls of falling out.

Please carefully assemble the linear guide or use plastic rails to assist.

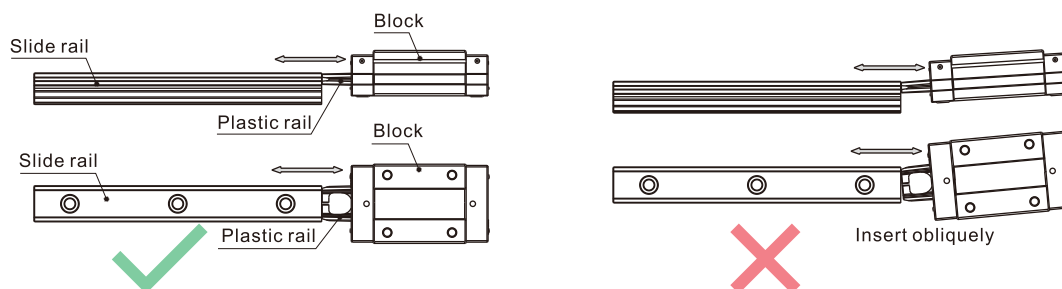

#### 2. Plastic rail installation

A plastic rail is equipped for block set. Please do not remove plastic rail whenever it is not necessary.

If plastic rail falls out and needs to be reinstalled, press the dustproof covers with fingers and install slowly to prevent balls from falling out due to misalignment of plastic rail.

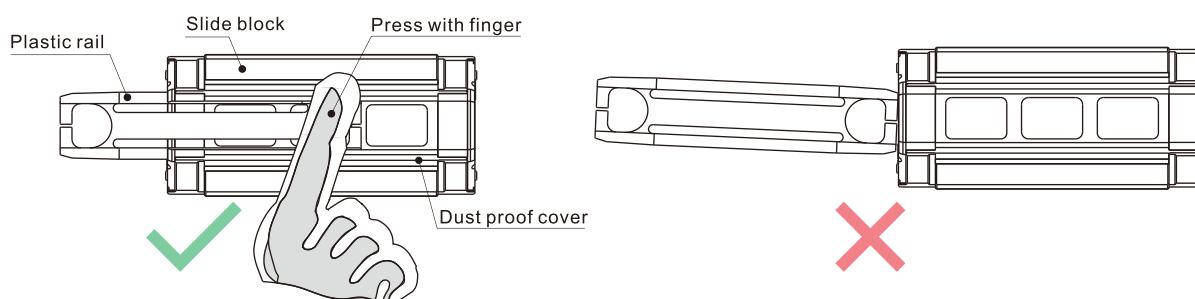

Press the dust-proof covers and insert plastic rail in alignment.

Without pressing dust-proof covers or insert plastic rail obliquely.

#### 3. Caution

- Parts may slide out if linear guide is put unevenly. Please be careful.
- Hitting or dropping linear guide could have huge effect on accuracy and lifespan even though appearance may remain intact. Please be careful.
- Do not disassemble linear guide as external objects may enter blocks and cause accuracy problem.

#### 4. Lubrication

- Linear guide have been treated with anti-rust oil during production. Before use, wipe the rail and treat it with lubrication.
- Do not mix lubricating oil (grease) with different properties.
- After lubrication, move block back and forth for the length of three blocks long and repeat at least 2 times to ensure there is a grease file on rail.

#### 5. Use

- The operating environment temperature should not exceed 80 °C, and the maximum temperature should not exceed 100 °C.
- Do not separate blocks from rail whenever it is not necessary. If you need to separate them, please use plastic rails to prevent steel balls from falling out.

#### 6. Storage

- When storing blocks, rails or linear guide set, please be sure that anti-rust oil is well applied and product is well sealed as well as placed horizontally. Avoid humidity and high temperatures environment.



AirTAC INTERNATIONAL GROUP

**BIBUS<sup>®</sup>** AirTAC

## Lineaire Geleidingen (2022A)

- LSH Series Standard Linear Guide
- LSD Series Low Profile Type Linear Guide
- LRM Series Miniature Linear Guide
- LGC Series Crossed Roller Way

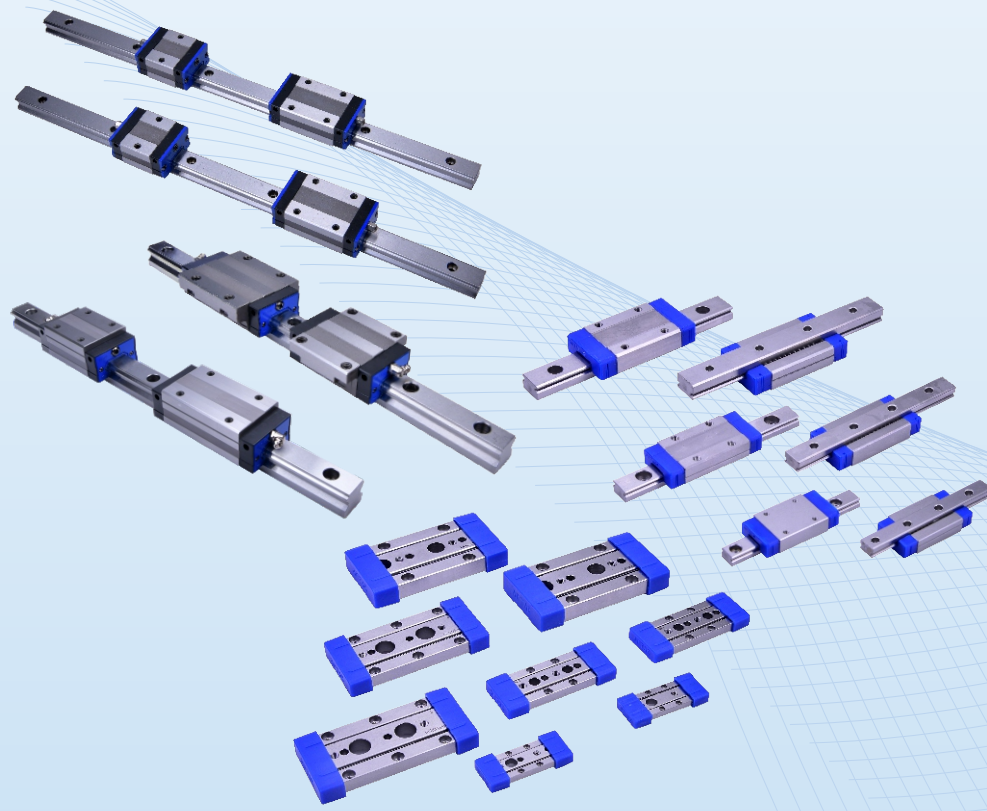

### BIBUS BV

- [BIBUS.nl](http://BIBUS.nl)
- [Sales@BIBUS.nl](mailto:Sales@BIBUS.nl)
- +31(0) 252 433733
- Meer en Duin 295
- 2163 HE Lisse
- Nederland

