

TAGGER® 320

Ultralight stitchfolding machine
for sheet material assembly

BÖLLHOFF

attexor



Stitchfolding

In stitchfolding, material tabs are cut out by punches. These tabs are then folded back and compressed. The result is a safe joining of sheet material and/or profiles.

TAGGER® 320

Today thousands of TAGGER® 320 machines are working all around the world. Users included leading manufacturers of white goods, as well as heating, ventilation, air-conditioning and filter equipment.

The low weight, low noise and the absence of recoil makes TAGGER® 320 a very user-friendly and extremely productive machine.

Advantages

- Very rapid and cost-effective joining
- More than one joint per second
- No separate fasteners to buy, sort or feed
- One tool for all thicknesses
- Simple and user-friendly handling
- Silent operation without sparks, fumes or noxious gases
- Ideal for mansize and larger workpieces
- Joining of pre-painted, coated and sandwich material possible
- No drilling or previous hole stamping
- No pre- or post work
- No complicated jigs or fixtures
- No burns, no oil, no scrap
- No thermal strain or stress around the joined area

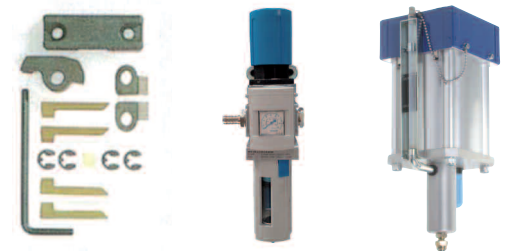
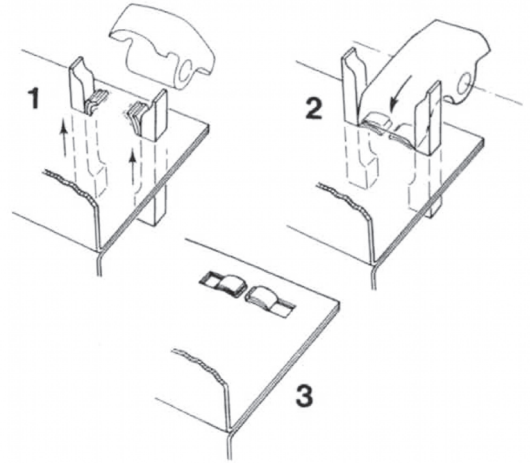

Technical specifications

A complete TAGGER® 320 unit consists of a compact workhead connected through a hydraulic hose to an air-over-oil pressure intensifier, a booster. The booster is ready for connection to the factory net of compresses air. Air preparing unit, service kit, balancer and rotator are available as options.

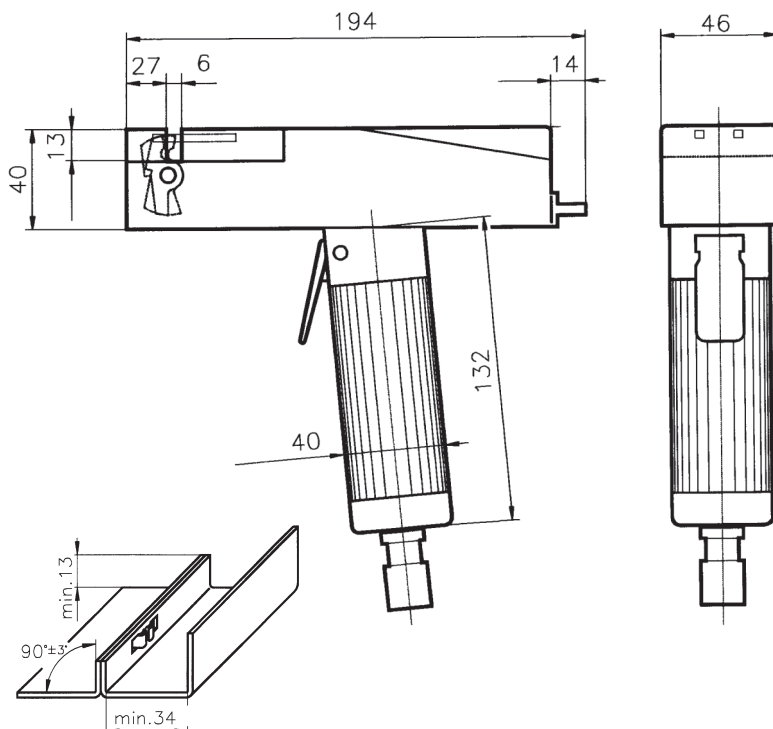

Workhead weight	2.1 kg	4.6 lbs
Total weight, including booster	10.4 kg	22.9 lbs
Working air pressure	6 bar	87 psi
Hydraulic pressure at 6 bar	365 bar	5'260 psi
Cycle time	0.6 s	
Max total thickness, mild steel	2.0 mm	0.08"
Max total thickness, stainless steel	1.4 mm	0.055"

Products numbers

Designation	Part No
TAGGER® 320, 2M HOSE	3 84242 10246
TAGGER® 320, 3 M HOSE	3 84242 10253
Air preparation unit, one-stage	3 92498 75300
Service kit	3 92498 75061
Balancer	3 92498 75320
Rotator	3 92498 68300



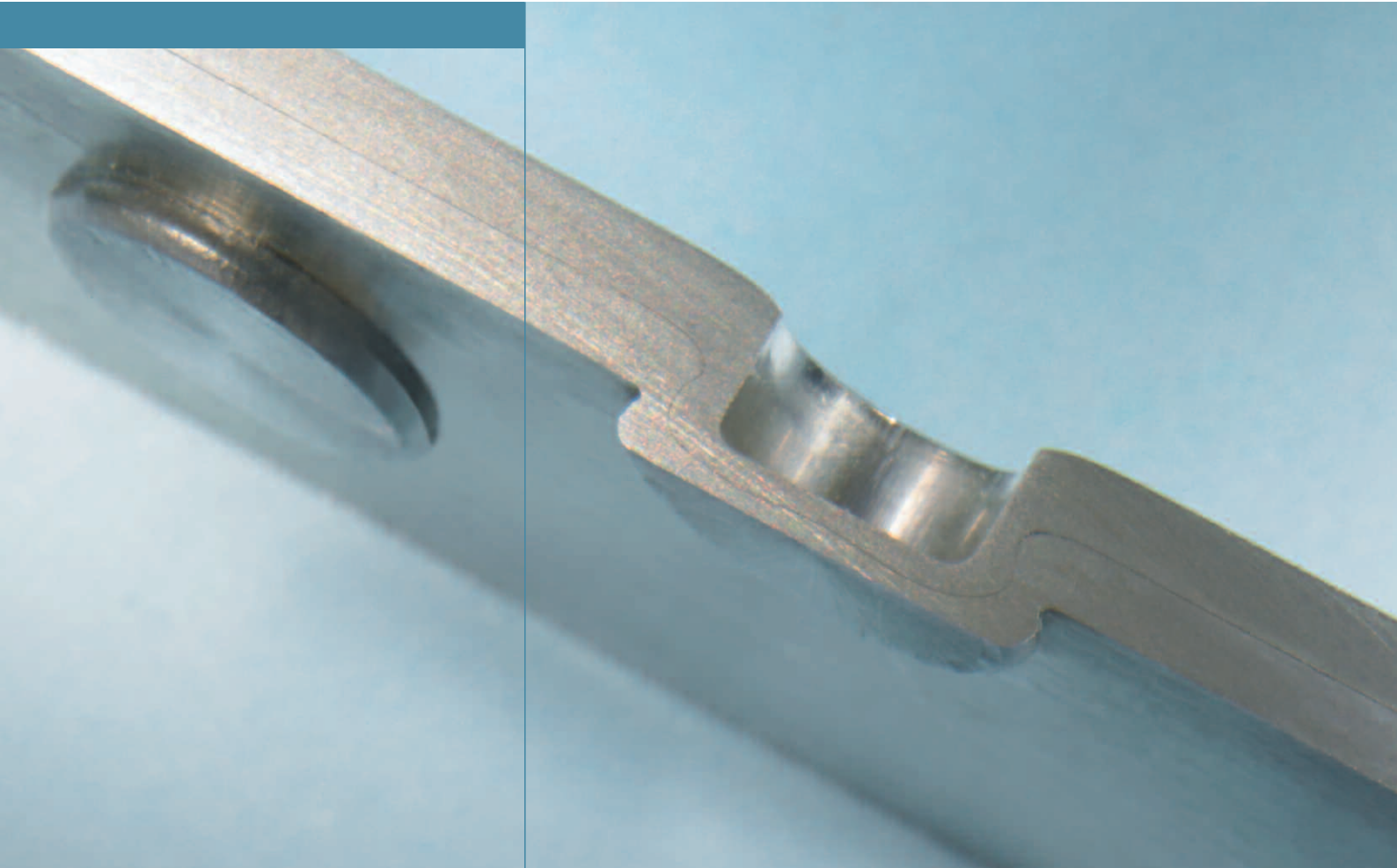

RIVCLINCH® (SPOT CLINCH®)

Metal joining without fasteners

BÖLLHOFF

attexor



RIVCLINCH® (SPOT CLINCH®) - General principles

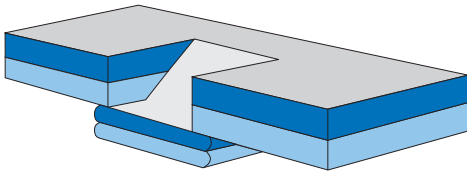

Rectangular Clinch, ST

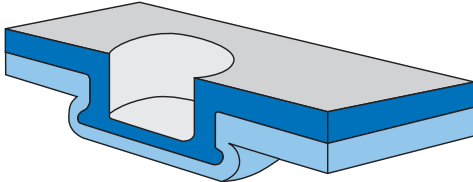

Round Clinch, SR

The clinching process is a method of joining sheet metal by localised cold-forming of the materials. This produces an interlocking joint between two or more layers of material.

Coated and painted sheet metals can also be joined together without altering the surface finish.

The RIVCLINCH® (SPOT CLINCH®) joining technique can be used to join steel and stainless steel materials as well as aluminium and/or non-ferrous materials based on a cost effective, environmentally friendly process.

Depending on the RIVCLINCH® (SPOT CLINCH®) joining tool selected, the resulting clinch will either be round or rectangular.

- The **SR round joint**, without cutting through the material, is gas tight. Consequently, it protects the coating better and provides high corrosion and fatigue resistance.
- The **ST rectangular** clinch joint is the product of a combined cutting and deforming process. It is primarily suited to multi-layer (up to 5 and more) and harder materials such as stainless steel.

Advantages

- Joints can be checked without damage
- No consumable items
- Low energy use
- No thermal load on joining zone
- No damage to surface finishes on the work piece
- Low maintenance costs
- Interim layers of film or adhesive can be incorporated in most cases
- Very good joint reproducibility
- Environmentally friendly workplace
- No fumes, no sparks, very little noise
- No pre/post treatment required, e.g. no pre-cleaning or subsequent removal of spray deposits around the joint

The Clinch Joint

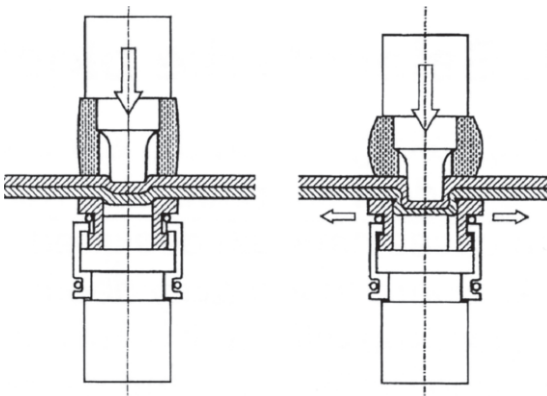

In the RIVCLINCH® (SPOT CLINCH®) joining process, the materials to be joined are firstly forced into the die with the punch. As soon as the lowest material is resting on the die anvil, it starts flowing sideways under the pressure being exerted by the punch. The movable die sections are pushed outwards and the flow of material forms the button-like joint. The punch is then returned to its starting position by the operator or by a pneumatic timer which removes the force. The joined part can now be removed and the side sections of the die are pulled back together by a spring.

The RIVCLINCH® (SPOT CLINCH®) joining system can be incorporated into existing press systems or custom built machines. It can be used to simultaneously set one or several points and can be integrated within manual machines and robotic equipment and systems.

Influential variables on the quality of a clinch Joint

Compared with other joining techniques, clinching is characterized by 4 essential parameters:

- Material ductility: in general, the required ductility values are 20% for a rectangular (partial cut) joint and 30% for a round joint.
- Access from both sides: needed for pressing the material between the punch and the anvil
- Better joint feasibility and strength with the punch on the thick side, when joining sheet metal with different thicknesses
- Once the joint is formed, the most relevant parameter is the residual bottom thickness, "St", which is directly related to the interlocking effect and consequently the joint strength.

Clinch Joint parameters and control

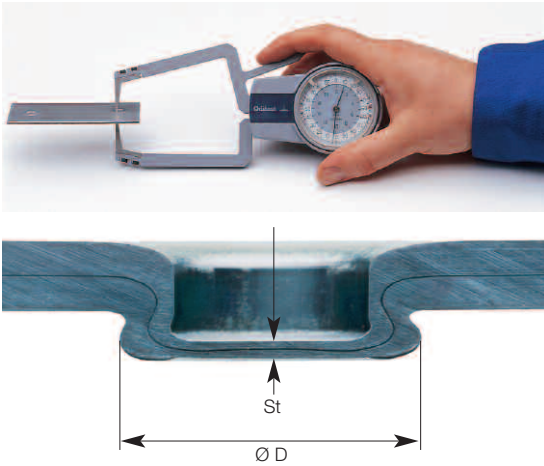

The RIVCLINCH® (SPOT CLINCH®) joint can be easily tested without being damaged, by measuring the residual base thickness, "St" and the joint diameter "D" on the die side of the joint.

These values are predetermined in laboratory tests for each application and recorded, with a test number, in a report. These parameters will be subsequently measured during production and compared with the reference data, thus guaranteeing reliable quality control of the RIVCLINCH® (SPOT CLINCH®) joint.

The residual base thickness, "St", is measured by hand using a calliper, as shown in the photograph. This allows quality checks to be carried out on random samples without interrupting production.

Process Monitoring



An electronic, "smart", process controller can be used to check the joining process for automated or mass production. The signals from a force sensor, installed on the C-frame, in conjunction with a displacement sensor measuring the tooling position, yield a force-displacement curve in real time for every clinch joint. The software allows check "windows" to be programmed along the curve, the last one being the final value of the completed joint. If the signal deviates from the reference windows, an error signal can be sent to the line controller or to the robot to stop the machine and for statistics analysis.

Strength value of RIVCLINCH® (SPOT CLINCH®) Joints

The shear and the cross-tension strength are a good means of comparing clinching with other joining methods such as spot welding, riveting or screwing. The graph on the right hand side shows the most current values for the standard tooling and mild steel.

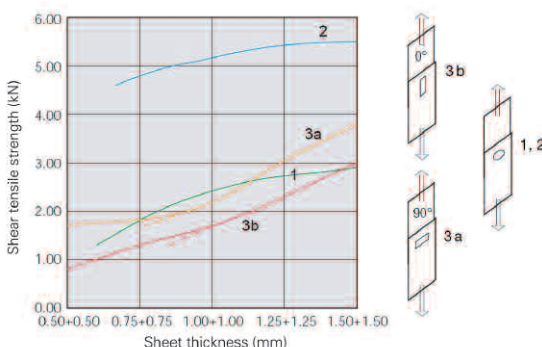

Static shear tensile strength depending on sheet thickness

Material: steel plate

Strength = ~ 300 N/mm²

1. SR 504, Ø 5 mm

2. SR 804, Ø 8 mm

3a. ST 432, placed transverse to load direction

3b. ST 432, placed longitudinal to load direction

There is a directional dependency involved when making a rectangular joint (ST). To achieve a greater strength, the load direction in the case of the rectangular joint should be transverse to the joining element, (3a) in the graph, rather than longitudinal (3b). The graph above also shows that the widening the joint diameter (1 to 2) also increases in strength.

The RIVCLINCH® (SPOT CLINCH®) tooling family

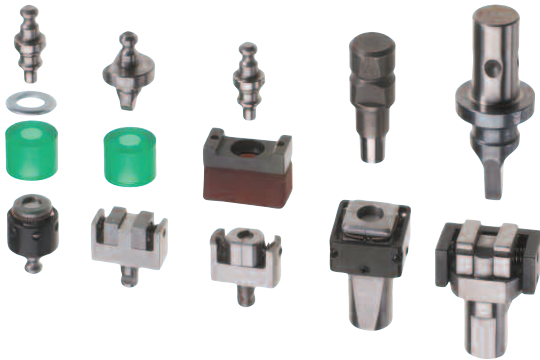

The central component of the RIVCLINCH® (SPOT CLINCH®) joining system is the tooling, or “tool kit”. These are available for round clinch joints with nominal diameters of 3, 4, 5, 6, 7, 8 and 10 mm and rectangular point joints with nominal widths of 3, 4, 4.3, 5 and 6 mm. Non standard dimensions are generally available from diameters of 1.0 to 10 mm.

A multiple tool holder can be used to integrate tool sets into corresponding RIVCLINCH® (SPOT CLINCH®) portable units, modular work heads or a press.

Design of the segmented die body



The RIVCLINCH® (SPOT CLINCH®) die comprises a basic die body and individual die segments, which are held in position by a steel spring.

A surrounding cage permanently secures the separate sections to the die body preventing them from falling out. The die cavity can be formed by 2, 3 or 4 segments with die designs being selected depending on the application requirements.

Punch Strippers



The stripper has two essential functions: keeping the sheet metal flat while clinching and pushing the sheet metal out of the punch during the return motion of the tooling.

A number of standard strippers are available, given that accessibility conditions may vary for each application. Special executions may be supplied if necessary.

Criteria for selection

Selecting the tooling is the first step involved when studying a new clinching application, because it will determine the pressing force and therefore the size of the clinching force unit and work head. This choice will depend on:

- Sheet metal thickness and material: each tooling has its own range of thickness per material type.
- Accessibility and space allowed for the tooling: the thicker the material, the larger the tooling required.
- Strength requirement: there is a direct relation between the size of the tooling and the joint strength. Priority can be given to obtaining either the highest strength, or minimizing the cost of the equipment by selecting a smaller tooling.
- Punch location: whenever possible, the punch should always be on the thicker layer, which will provide a higher joint strength.
- Number and variability of sheet layers: a rectangular tooling should be selected if a low ductility material is used or if more than 2 layers, unequal thicknesses or variable total thickness are involved in the same application.

Compatibility of tooling with the machine

Tool force versus die diameter

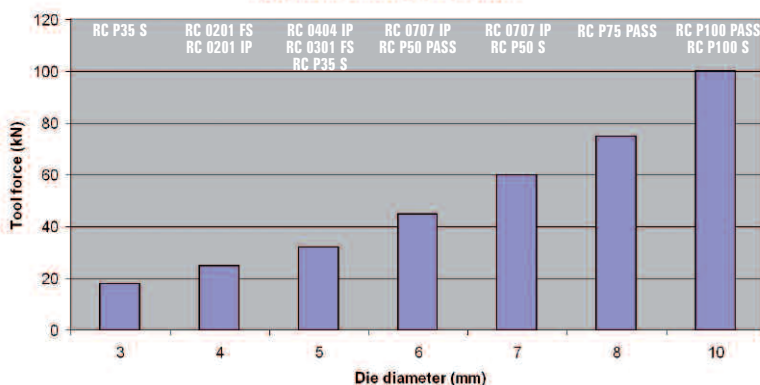

The RIVCLINCH® (SPOT CLINCH®) work heads are designed to accommodate the various standard tooling. A corresponding force unit with appropriate setting force exists for each die diameter. This makes it quite simple to select the clinching machine. Irrespective of the die diameter or width, a suitable work head is available in the portable or in the modular range.

Tool selection based on clinch area and materiel thickness

The main parameter for selection is the clinch area, in general defined by the edge of the sheet metal wall. The width or the diameter of the die must match the edge width (A) so that the die's outer dimension is at least equal to the sheet metal edge. On punch side, the limiting dimension will be the width of the stripper front piece. A special stripper front piece may be provided in case of limited access.

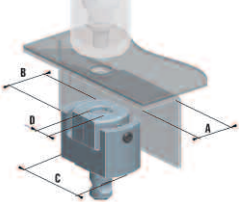
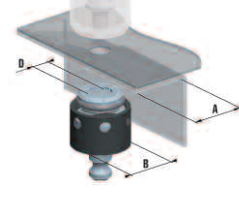
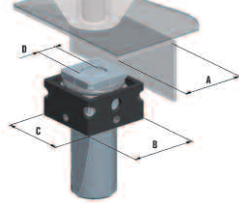
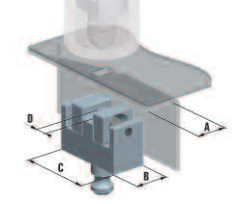
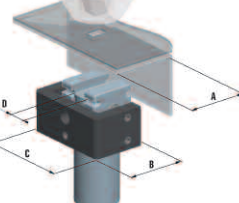
Tooling type	Geometry of clinch area	A (mm)	B (mm)	C (mm)	D (mm)	Total thickness (mm)	Setting force (kN)
SR302		8.0	8.0	22.0	3.0	0.5 – 2.0	18
SR402		8.0	8.0	22.0	4.0	0.5 – 2.5	25
SR502		10.0	10.0	22.0	5.0	1.0 – 3.0	35
SR602		12.0	12.0	25.0	6.0	1.0 – 3.0	40
SR403		13.0	13.0	13.0	4.0	0.8 – 2.5	25
SR503		14.0	14.0	14.0	5.0	1.0 – 3.0	32
SR603		16.0	16.0	16.0	6.0	1.0 – 4.0	45
SR703		18.0	18.0	18.0	7.0	1.0 – 4.0	60
SR704		18.0	18.0	18.0	7.0	1.5 – 4.0	60
SR804		22.0	22.0	22.0	8.0	2.0 – 6.0	75
SR1004		22.0	22.0	22.0	10.0	2.0 – 6.0	100
ST302		8.0	8.0	20.0	3.3	0.5 – 2.5	20
ST432		10.0	10.0	22.0	4.3	1.0 – 3.0	35
ST502		12.0	12.0	22.0	5.0	1.5 – 4.0	50
ST602		21.0	21.0	30.0	6.0	2.0 – 6.0	75

Speciality tooling

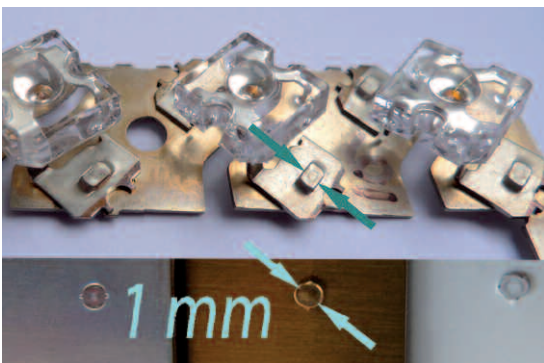

Micro clinch

BOLLHOFF ATTEXOR provides optimized and advanced clinching solutions for specific industries, notably:

- **Micro clinch tooling**, which have been used in the electronic and watch industries for 15 years, with a small record die diameter of 1.0 mm
- **Tooling for electric contacts**, with diameters ranging between 2 to 3 mm
- **Tooling for filters**, ST402, accepting high filtering fabric material thickness in the ventilation industry
- **Tooling for ventilation ducts**, which enables fast lateral displacement of machine

Portable RIVCLINCH® (SPOT CLINCH®) machines



The very wide range of clinching hand tools and portable machines offers the opportunity to incorporate clinching into your operation for a minimum investment cost and to provide the best solution for practically every application. A complete RIVCLINCH® (SPOT CLINCH®) hand tool system is composed of the following parts:

- Work head: design depends on the model selected for the particular range of applications.
- Tool kit: suited to the application
- Rotating suspension, by means of rotating ring or a complete gyroscopic suspension
- Air-to-Oil pressure booster with 1:60 ratio. N.B. The booster is not needed for the IP series which are 100% pneumatic.
- *Pack of 2 m flexible hoses (hydraulic and pneumatic hoses in safety sleeve), with a 3 m variant
- *Balancer, depending on the weight of the work head
- *Optimized Cycle Controller (OCC) for fast and automatic clinch cycle

* = Options

Installation of a portable clinching machine

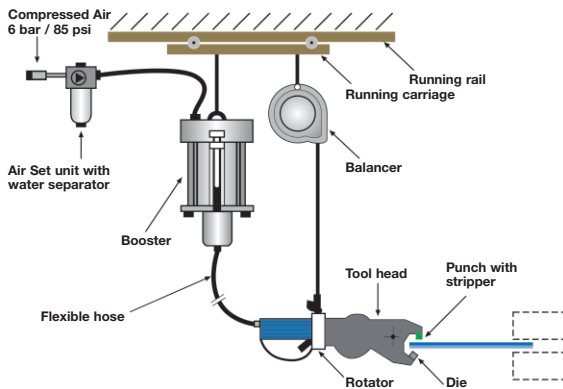

The booster and the balancer should be installed on a combined running cradle to avoid collisions, while maintaining the suspension cable of the work head perfectly vertical over the whole work zone.

The air supply must be dry, filtered and regulated, with a minimum size of 1/2" for ensuring the shortest possible cycle time.

All the RIVCLINCH® (SPOT CLINCH®) systems are designed for operation without lubricator on the air preparation unit.

How to select the machine

Once the tooling has been selected (see page 5) the choice of the work head will be dictated mainly by the geometry of the product to be clinched, and by accessibility to the clinch area.

Small edges: the examples here show assembly of the external edges of cabinets, housings and walls of large size products. This choice is advantageous given the high speed, light weight and the mobility of the tool which offers exceptional productivity.

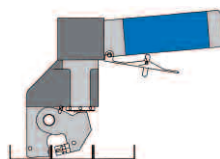

RC 0201FS Wall structure

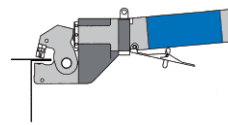

RC 0201FS Edge of cabinet

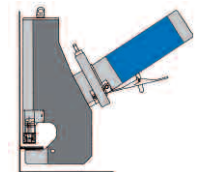

RC 0501FS Cabinet wall

Medium range: the assembly of profiles or folded edges which require a larger jaw opening. The quick and safe closing jaw of the IP models is a perfect solution for such products.

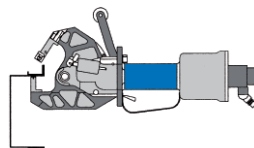

RC 0404 IP Boxes and ducts

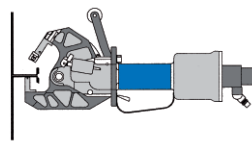

RC 0404 IP Wall panel

Large structures: it is quite often necessary to set the clinch joint further away from the edge, or for passing over steps. Working from the top of a product or accessing a more confined box is often necessary. This type of machine is the best solution in this case as various C'frame dimensions and geometries can be supplied using the same force unit.

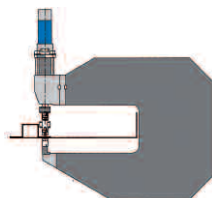

RC P50 PASS Large Frame

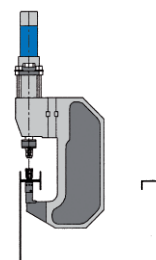

RC P50 PASS Housing

Portable RIVCLINCH® (SPOT CLINCH®) machines

FS Series (booster driven): light and fast hand tools

Light weight and fast tools for joining edges and flat panels. Convenient for cabinets, refrigerated window displays, vending machines, freezers, ventilation and many other sectors.



Models	RC 0201 FS	RC 0201 FS V2	RC 0301 FS	RC 0501 FS	RC 0501 FS V1
Weight of work head (kg)	1.7	2.0	3.5	4.5	4.8
Setting force (kN)	25	22	35	35	24
Cycle time (s)	0.5 – 0.8	0.5 – 0.8	0.8 – 1.0	0.8 – 1.2	0.8 – 1.0
Piston stroke (mm)	7	7	7	8	7
Depth of jaw (mm)	16	6	35	35	20
Noze height (mm)	25	16	52	45	20
Maximum thickness, Mild steel (mm)	2.5	2.0	3.0	4.0	2.5
Maximum thickness, Stainless st. (mm)	1.8	1.2	2.0	2.5	1.8

IP Series, 100% pneumatic, quick locking jaws

Multi-purpose, jaw type clinchers, ideally suited for applications with medium distance to access the joint. Wide opening with safe pre-stroke, by manual or automatic fast closing of the work head (patents pending). Many sectors of applications with building components, ventilation ducts, HVAC (Heating, Ventilation and Air-Conditioning), appliances, automobiles, etc.



Models	RC 0201 IP	RC 0404 IP	RC 0404 IP V2	RC 0604 IP	RC 0706 IP
Weight of work head (kg)	2.7	4.5	4.7 à 5.7	7.0 à 7.3	22
Setting force (kN)	25	35	35	35	50
Cycle time (s)	0.3 – 0.7	0.5 – 0.9	0.5 – 0.9	0.5 – 0.9	0.7 – 1.2
Work stroke (mm)	7	7	7	7	8
Jaws opening (mm)	-	34	34	36	60
Depth of jaw (mm)	20	45	45	60	70
Maximum thickness, Mild steel (mm)	2.5	3.0	3.0	3.0	4.5
Maximum thickness, Stainless st. (mm)	1.8	2.5	2.5	2.5	3.0

PASS Series – C-frame type, multi-purpose, large size work-heads

Portable, powerful tools, hydraulically powered by compressed air boosters. Multi-purpose C'frame type work head family, equipped with the unique PASS (Passive Approach Stroke System) option. The pre-stroke is pneumatic and can be activated independently of the work stroke, for a safe, long approach stroke and for easy tool positioning. Wide range of C'frame dimensions with depths up to 450 mm, for application in all industries, large assemblies and cabinets.



Models	RC 1106 P35	RC 1106 P50	RC 4006 P50	RC 0606 P75
Weight of work head (kg)	16	17	115	50
Setting force (kN)	35	50	50	75
Cycle time (s)	0.6 – 0.8	0.7 – 0.9	0.7 – 0.9	0.7 – 1.2
Piston stroke (mm)	8	8	8	8
PASS opening (mm)	60	60	60	60
Depth of jaw (mm)	110	110	400	55
Maximum thickness, Mild steel (mm)	3.0	4.0	4.0	6.0
Maximum thickness, Stainless st. (mm)	2.5	3.0	3.0	3.5

Portable RIVCLINCH® (SPOT CLINCH®) Modular systems for integration and automation

The modular program is intended for line builders and integrators and for people requiring efficient tools which enable rapid creation of customized solutions and suited to a wide variety of clinching assembly tasks. The solutions can involve bench mounted or stand alone machines, special assembly work stations, automatic assembly lines or robot stations.

The systems are composed of cost effective standard hydraulic work heads, powered by air-to-oil pressure boosters simply connected to compressed air, for unlimited combinations of force unit capacity, stroke length, C'frame depth and work heads.

Multiple work head stations can be easily designed and built with pre-adjusted components, and without the use of a complicated electro-hydraulic power installation, and can be immediately operational. The limited oil volume also prevents large oil leakages and the inevitable dirtiness of usual hydraulic installations over time.

Once the tool kit type, dimension and setting force are defined as function of the application (see page 3 and 4), there will always be the right work head to power it and to build the clinching installation.

Accessories include boosters, tool holders, punch strippers, die protections, compensated supports for adaptation to automatic operation, hand triggers and foot pedals, various sensors for automatic control, optimized cycle controller and process monitoring device for full production control. Some portable applications are also based on modules, with the aid of accessories like balancers and gyroscopic suspensions with appropriate load capacity.



Boosters

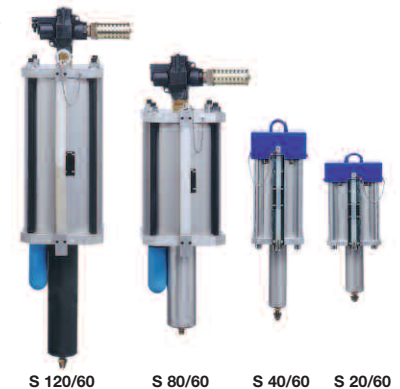

The PASS solution for long stroke



As described on page 7 for portable machines, a long pre-stroke can be provided by a small pneumatic cylinder, which eliminates the need for large oil flows. Therefore only one pressure booster can power several work heads by just acting during the work stroke. Another advantage of the PASS solution is to save cycle time when making several clinch joints in a row without having to activate the long approach and return strokes. Each module range, from 35 kN to 300 kN, can be equipped with the PASS option.

The usual modular installation comprises one or several work heads, mounted on sliding (compensating) supports, and powered by a booster. The work piece must be introduced automatically or manually in-between the punch and the die, without hurting the tooling or the tool holder. Prior to the clinching cycle, the work head is moved on its sliding support until the part comes into contact with the tooling attached to the C'frame side. In this way the cycle is operated smoothly without any distortion to the clinched part or to the clinching tooling and work head.

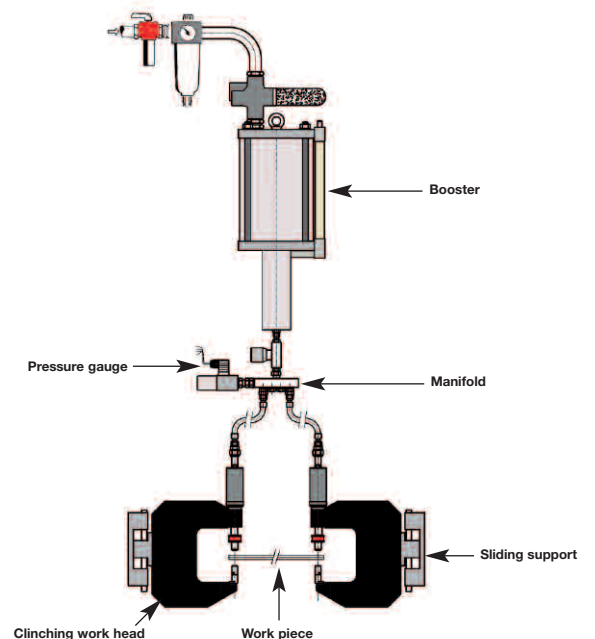

Robotic PASS work heads

New range of compact clinching machines with integrated pneumatic-hydraulic force unit for use as:

- Bench mounted (manually operated)
- Automatic lines (integrated clinching heads)
- Robot mounted

Simply powered by a 6 bar (85 psi) air compressed air line, they offer exceptional performance in terms of cycle time (up to 80 joints per minutes), of energy saving (the full power is only activated during the minimum work stroke), of flexibility (with a pre-stroke of 52 mm (2")) for easy accessibility, and of possibilities of various pre-installed sensors for process control.



RIVCLINCH® (SPOT CLINCH®) Modules

The work heads are grouped according to their maximum joining force.

Series RC P35 / P50 S

With 35 or 55 kN joining force, light C' frames, all possible dimensions up to 1300 mm are available. The PASS option is available for all modules.

It uses standard tool kits: see corresponding setting force and sheet metal thickness on page 5.



RIVCLINCH® (SPOT CLINCH®) type	Setting Force (Kn)	Piston Stroke (mm)	C'frame depths (mm)					
P35 S	35	8 - 50	35	70	110	200	300	650
P35 PASS	35	8 - 60						
P50 S	55	8 - 50						
P50 PASS	50	8 - 60						

Series RC P75 / P100 S

With 75 or 105 kN joining force. For thick sheet metal (up to 8 mm total thickness) and for multiple tooling configuration. Special strippers adapted to the application may be supplied.

The PASS option is available for all modules.

It uses standard tool kits: see corresponding setting force and sheet metal thickness on page 5. Add the force of all tool kits in order to select the corresponding work head.

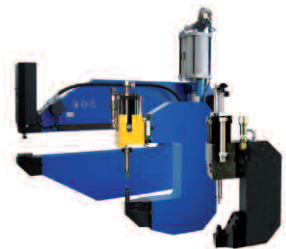

RIVCLINCH® (SPOT CLINCH®) type	Setting Force (Kn)	Piston Stroke (mm)	C'frame depths (mm)				
P75 S	75	8 - 100*	100	160	250	400	650
P75 PASS	75	8 - 100					
P100 S	105	8 - 25					
P100 PASS	105	8 - 100					

* Only with hydraulic power pack at 250 bars

Series RC P200 / P300 S

With 200 or 300 kN joining force. Clinching presses with customized tooling arrangement (multiple tool kits) and C' frame depth according to the application. The PASS option is available for all modules.

It uses standard tool kits: see corresponding setting force and sheet metal thickness on page 5. Add the force of all tool kits in order to select the corresponding work head.



RIVCLINCH® (SPOT CLINCH®) type	Setting Force (Kn)	Piston Stroke (mm)	C'frame depths (mm)		
P200 S	240	8 - 25*	100	200	300
P200 PASS	240	8 - 100			
P300 S	300	8 - 100*			
P300 PASS	300	8 - 100			

* Only with hydraulic power pack at 250 bars

Examples of RIVCLINCH® (SPOT CLINCH®) Joint applications

Building sector

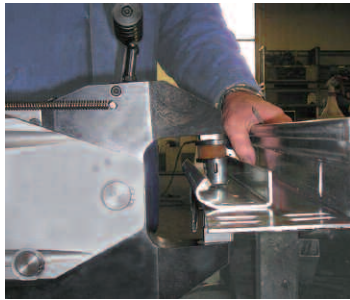

Garage doors

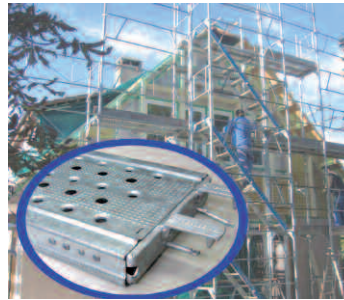

Scaffolders

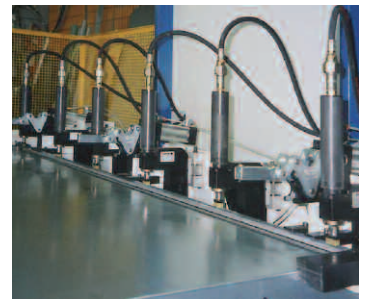

Door frames

Heating, Ventilation, Air Conditioning (HVAC)

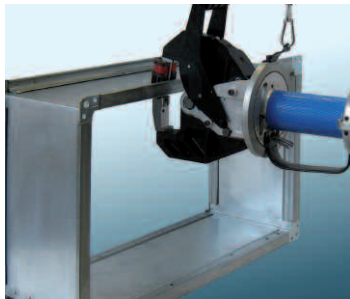

Ventilation ducts



Solar collectors

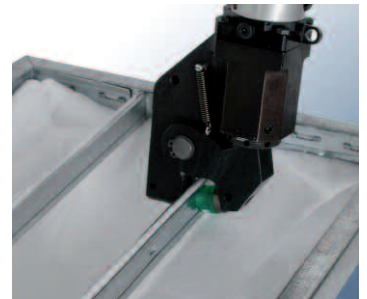

Ventilation filters

Appliances



Stoves



Washing machines

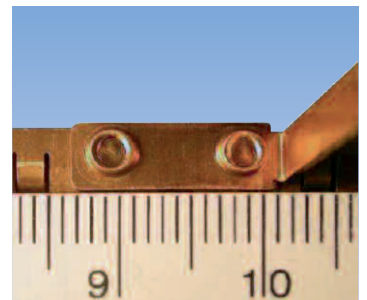

Electric contacts

Automotive sector



Heat shields



Window mechanisms



Bonnets/hoods - Boots/trucks

BOLLHOFF ATTEXOR of Ecublens/Lausanne, Switzerland, is a manufacturing company, **leading in the domain of clinching**, a technology for sheet metal “fastening without fasteners”.

BOLLHOFF ATTEXOR offers a large range of tooling and machines worldwide based on unique **RIVCLINCH®** (SPOT CLINCH®) (clinching) and **TAGGER®** (stitch-folding) joining techniques.

BOLLHOFF ATTEXOR is represented throughout the world by a network of competent partners, distributors and agents.

BOLLHOFF ATTEXOR success stems from more than 30 years' experience in most of the sheet metal assembly sectors throughout the world. Its engineering team is the **pioneer in Europe**. This success is also based on its ability to offer solutions to most applications, a network of highly qualified partners, distributors and agents, and on an uncompromised **Swiss quality**.

See the list of our distributors on the website: www.bollhoff-attexor.com

For more information please contact us at sales_bax@bollhoff.com



Böllhoff International with companies in:

Argentina
Austria
Brazil
Canada
China
Czech Republic
France
Germany
Hungary
India
Italy
Japan
Korea
Mexico
Poland
Romania
Russia
Slovakia
Spain
Switzerland
Turkey
United Kingdom
USA

Apart from these 23 countries, Böllhoff supports its international customers in other important industrial markets in close partnership with agents and dealers.



Subject to technical change.
Reprinting, even in extract form, only permitted with express consent.
Observe protective note according to ISO 16016.

Distributed by

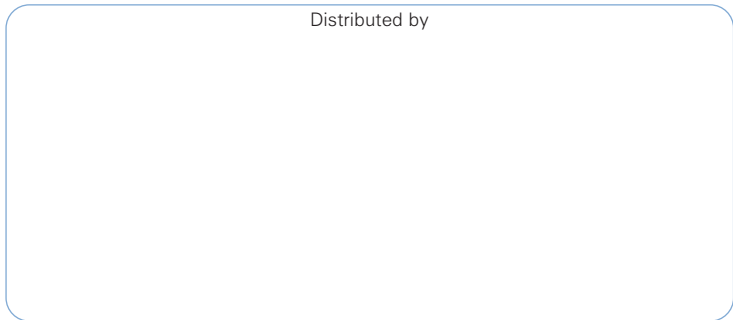

Böllhoff Attexor SA
6, Chemin des Larges Pièces - Z.I.B · 1024 Ecublens · Switzerland
Tel. : +41 21 694 80 00 · Fax : +41 21 694 80 01
Email : sales_bax@bollhoff.com · www.bollhoff-attexor.com

