



Lever Switch 351RHS

With or without detent.

The Lever switch 351RHS, with integrated mounting bracket for standardised steering columns, is used for direction control. Optionally available with mini push buttons which can be used to operate the horn and other functions. The robust Lever switch 351RHS is used in agricultural vehicles, construction machinery and self-propelled machinery. Using proven technology, these steering column switches are robust and reliable even under tough working conditions.

Technical specifications

- High reliability and long service life thanks to contactless reed technology
- Developed for harsh operating conditions, high protection class IP67 for electronics
- Robust and space-saving design
- 3 detent positions for direction control
- Switching signals optionally overlapping for the optional detection of line interruptions
- Integrated mounting bracket available for steering columns for diameters of 38 mm or 45mm
- Mechanical locking in centre position
- Available with or without push button

Technical drawing

IMAGE 1/2

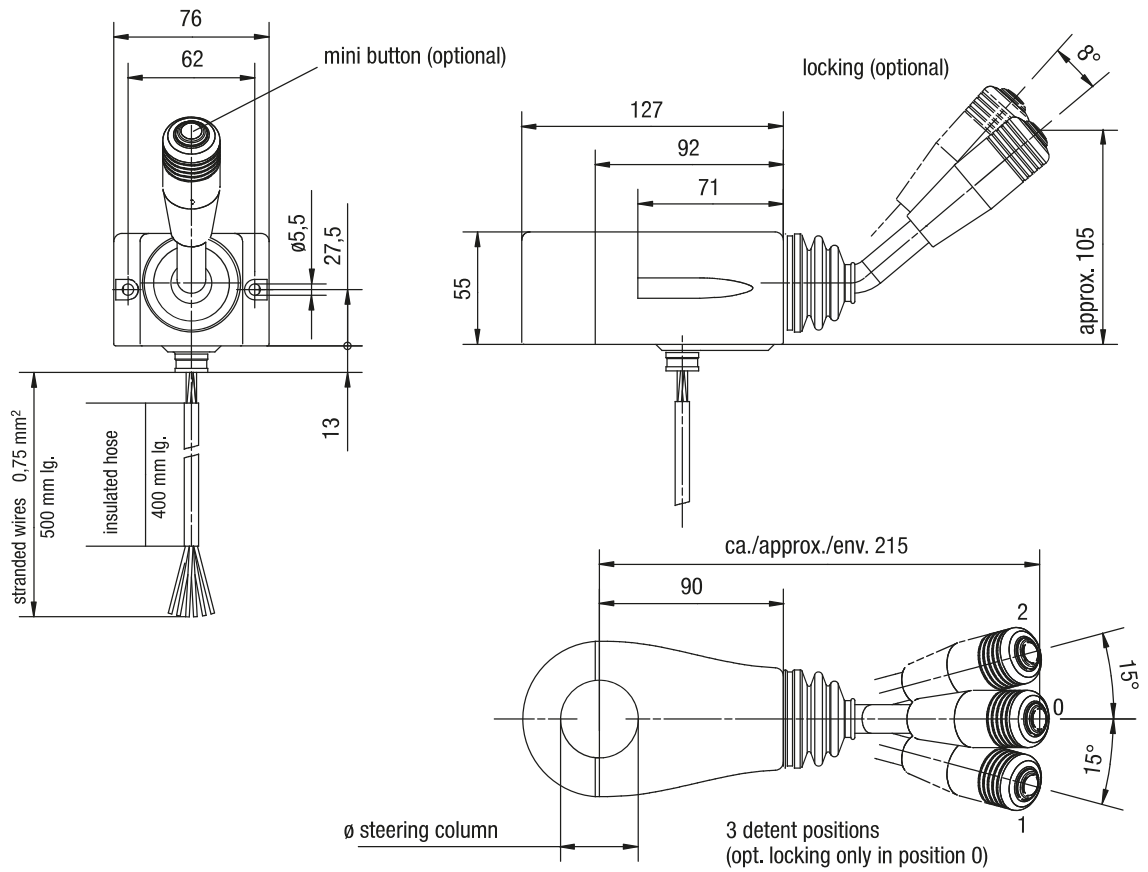
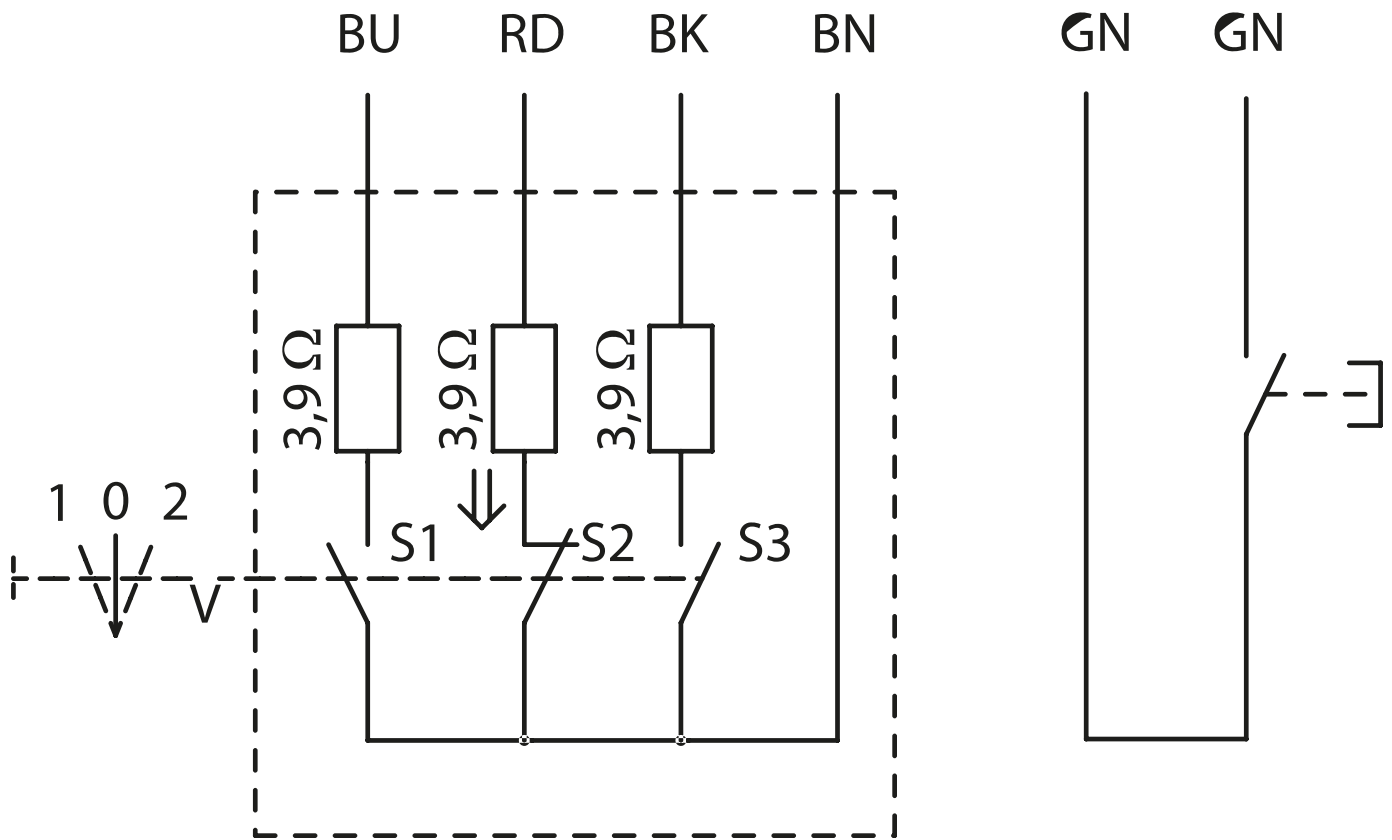

IMAGE 2/2



Switch in zero position drawn with S2 in
actuated state (↓)

S3 is closed in position 1

S1 is closed in position 2

Product options

IMAGE 1/1

ORDERING KEY

351RHS						Lever switch
						Diameter of steering column
	3					D 38
	4					D 45
						Function
		1	1			No detent, mechanically lockable (self-resetting to centre position)
		3	0			Detent, not mechanically lockable (3 detent positions)
		3	1			Detent, mechanically lockable
						Switching points
				0		Overlapping
				1		Not overlapping
						Handle version
					T	Push button (omitted if no push button selected)

Article characteristics

Attribute	351RHS...	351RHS3...	351RHS3...T	351RHS4...	351RHS4...T
Max. switching voltage	36 V DC				
Max. switching current	0.5 A				
Max. switching power	10 W				
Max. switching power	10 VA				
Contact form	NO				
Polarity reversal protection	no				
maximum switching voltage mini push button switches	36 V DC	-	36 V DC	-	36 V DC
maximum switching current mini push button switches	0.5 A	-	0.5 A	-	0.5 A
maximum switching power mini push button switches	10 W	-	10 W	-	10 W
maximum switching power mini push button switches	10 VA	-	10 VA	-	10 VA
contact form mini push button switches	NO	-	NO	-	NO
Deflection	± 15 °				
Steering column diameter	-	38 mm		45 mm	
button stroke	2 mm	-	2 mm	-	2 mm
Protection class, electronic	IP67 DIN EN 60529				
Operating temperature min.	-30 °C				
Max. operating temperature	75 °C				
Min. storage temperature	-30 °C				
Max. storage temperature	75 °C				
Cable type	FLRY				
Cable length	0.5 m				