

Do your products require special ambient conditions and place high demands on the surface of the press you use? Does it have to be not only stainless and easy to clean and disinfect, but also impervious to the cleaning agents used?

This is where mäder **LAB presses** can be used.

LAB Press

- Basic body of chrome-plated aluminium
- All external parts of stainless steel or plastic
- Press rams TiN-coated
- Moving parts mounted in bushes of FDA-approved plastic

Variants

Instead of the standard **LAB press**, hand-operated presses from the standard range can also be adapted to your requirements.

- Standard hand-operated press models with nickel-plated cast body surface
- Press body of stainless steel

Just ask about feasibility.

Table 1 (included)

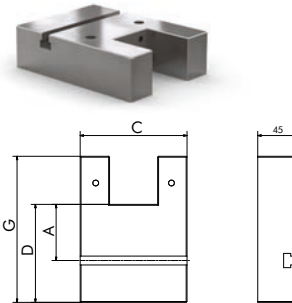

Table 2 (optional)

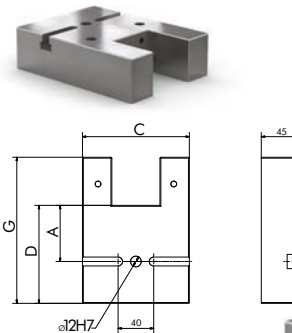
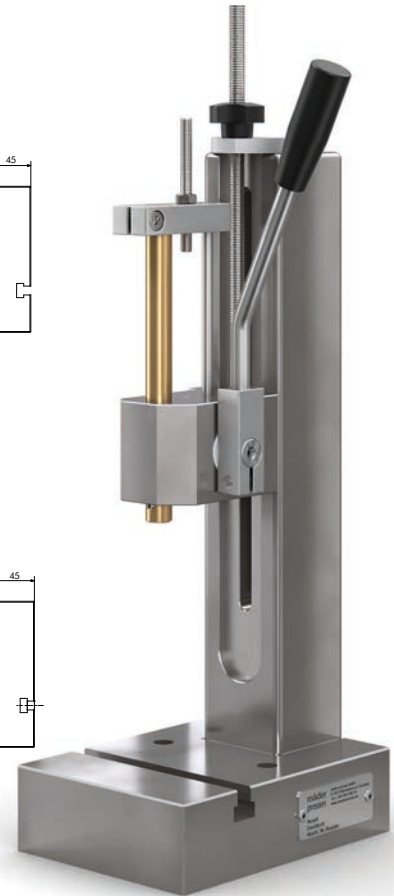
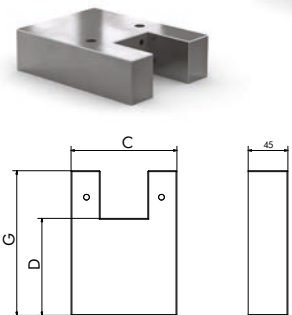
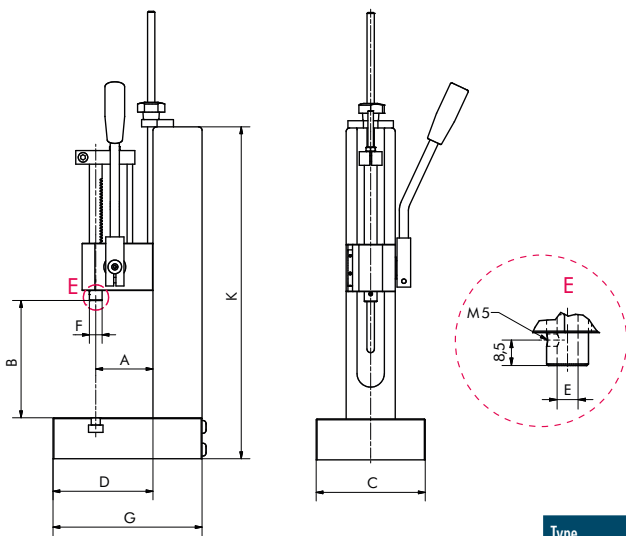

Table 3 (optional)



LAB Press Z1-80



Example:

Standard press with chemically nickel-plated cast part, otherwise stainless steel.

Type			LAB Press Z1-80	LAB Press Z1-80 L
Capacity		N	750	750
Working stroke		mm	80	80
Throat	A	mm	63	63
Daylight	B	mm	45-250	45-350
Table size	CxD	mm	120 x 110	120 x 110
Ram bore \varnothing x Depth	E	mm	7H7 x 20	7H7 x 20
Ram \varnothing	F	mm	14	14
Stand height		mm	365	465
Space requirement	CxG	mm	120 x 164	120 x 164
Weight		kg	6.1	6.3
Table plate				
Table 1 T-slot T-slot width similar to DIN 650		mm	10	10
Table 2 T-slot with TB		mm	12H7	12H7
Table 3 plan				

The accessories

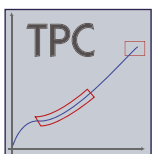
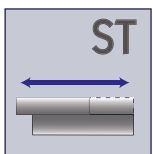
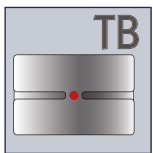
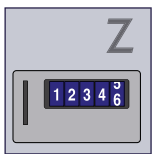
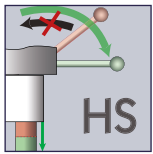

APZ range

mäder rack and pinion presses transmit their force constantly over the whole stroke length. The direct transmission of force via the manual lever allows fine control. Rack and pinion presses are therefore used where a constant force characteristic over a longer stroke is required.

Manual lever with ergonomic user comfort

- ▶ Can be turned through 360°: adaptable for any body size and application.
- ▶ Lever angled to the side: free view of work area and ergonomically comfortable position.
- ▶ **R/L Version:** simple and easy conversion for left-handers without losing the tool setting. Ideal for job sharing on one press.



Manual lever can be refitted for right and left-handers

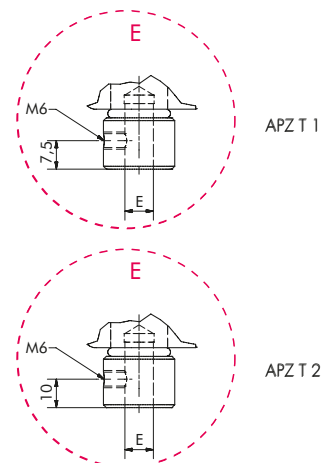
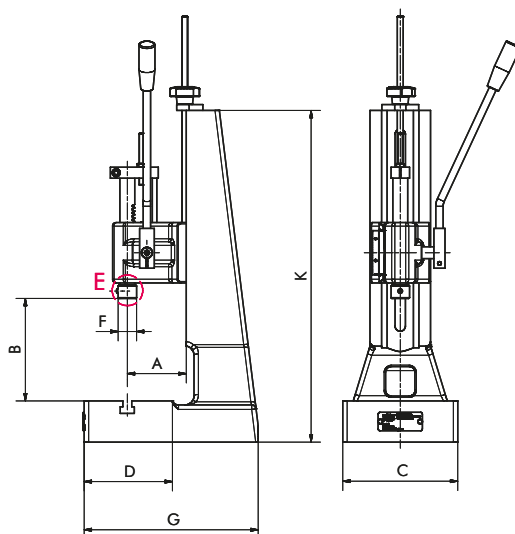
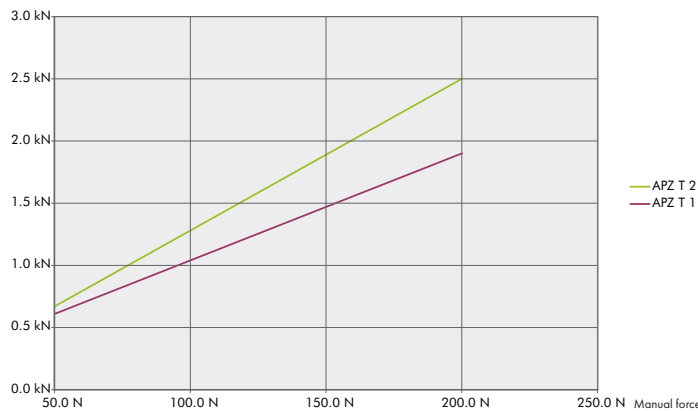

APZ range
L-APZ range with extra large daylight



APZ T 1-40

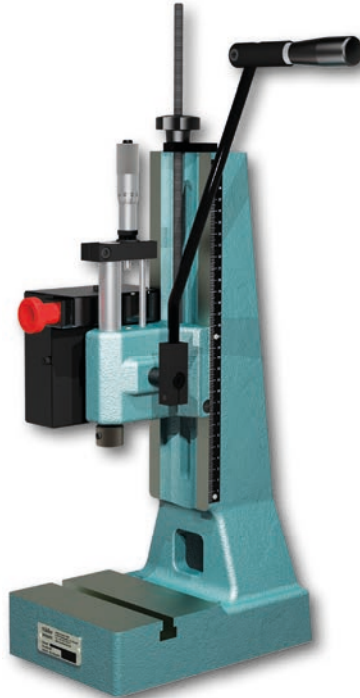

APZ T 2-50

with accessories
HS – Return travel lock
MICRO – Micrometer stop
Equipped with ERGO hand lever**

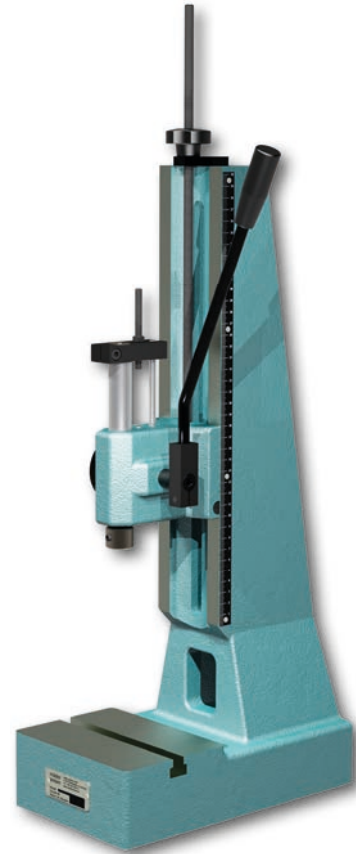

L-APZ T 2-50

Rack and pinion presses

Type			APZ T1-40	APZ T1-90	APZ T2-50	APZ T2-100	L-APZ T2-50	L-APZ T2-100
Capacity		kN	1.5	1.5	2.5	2.5	2.5	2.5
Working stroke		mm	40	90	50	100	50	100
Throat	A	mm	63	63	80	80	80	80
Daylight	B	mm	40 - 235	40 - 235	42 - 290	42 - 290	55 - 390	55 - 390
Table size	CxD	mm	110 x 65	110 x 65	157 x 115	157 x 115	157 x 115	157 x 115
T-slot width similar to DIN 650		mm	10	10	12	12	12	12
Ram bore Ø x Depth	E	mm	10H7 x 25	10H7 x 25	10H7 x 25	10H7 x 25	10H7 x 25	10H7 x 25
Ram Ø	F	mm	25	25	25	25	25	25
Space requirement	CxG	mm	110 x 164	110 x 164	157 x 237	157 x 237	156 x 275	156 x 275
Stand height	K	mm	355	355	450	450	570	570
Weight		kg	ca. 8.5	ca. 8.5	ca. 21	ca. 21	ca. 29	ca. 29

Accessories (see Page 8-9)	Please specify when ordering.					
Return travel lock	HS	HS	HS	HS	HS	HS
Micrometer stop	MICRO	MICRO	MICRO	MICRO	MICRO	MICRO
Counter	Z	Z	Z	Z	Z	Z
Table bore 12 ^{H7}	TB	TB	TB	TB	TB	TB
Left/right-hander version*	R/L	R/L	R/L	R/L	R/L	R/L

* Can only be combined with the MICRO and TB accessories.

**Not included. Accessories must be ordered separately.

The accessories

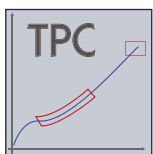
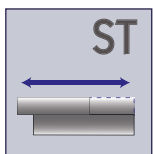
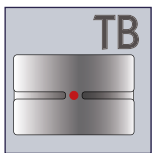
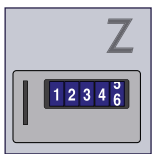
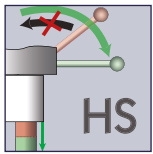

VZ range

The square ram has significant advantages compared with the round ram:

- ▶ Absolute protection against twisting
- ▶ Press ram guide free from play
- ▶ Readjustable guide rails for square ram
- ▶ Large tool locating surface
- ▶ Guides in tool therefore usually unnecessary
- ▶ Practically maintenance-free operation

mäder rack and pinion presses with square ram are ideal tools for manufacturing small precision parts with tight tolerances in small and medium-sized batches where automation would be too cost-intensive.

Manual lever with ergonomic user comfort

- ▶ Can be turned through 360°: adaptable for any body size and application.
- ▶ Lever angled to the side: free view of work area and ergonomically comfortable position.
- ▶ **R/L Version:** simple and easy conversion for left-handers without losing the tool setting. Ideal for job sharing on one press.



Manual lever can be refitted for right- and left-handers

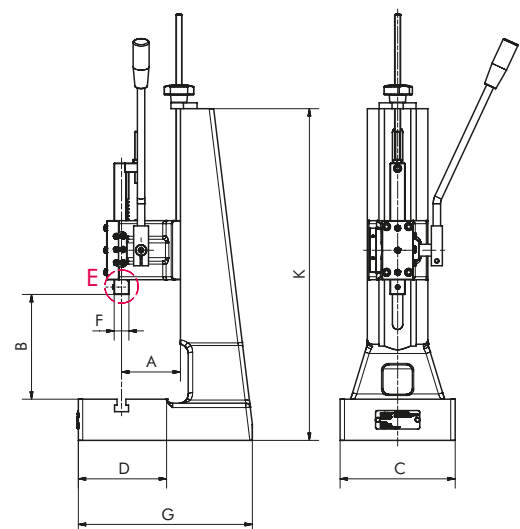
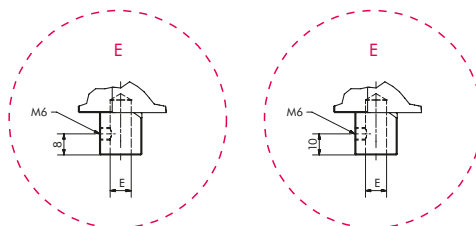
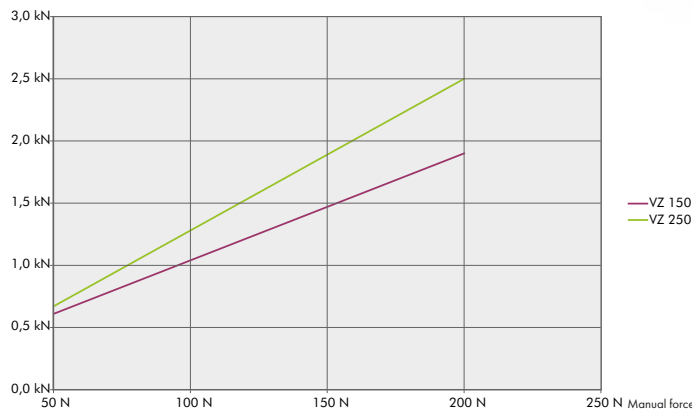

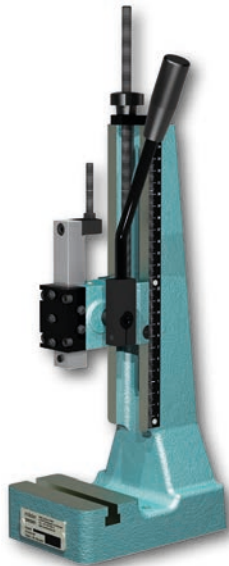

VZ 150-40



VZ 250-50

with extras
HS – Return travel lock
MICRO – Micrometer stop
Equipped with ERGO hand lever**

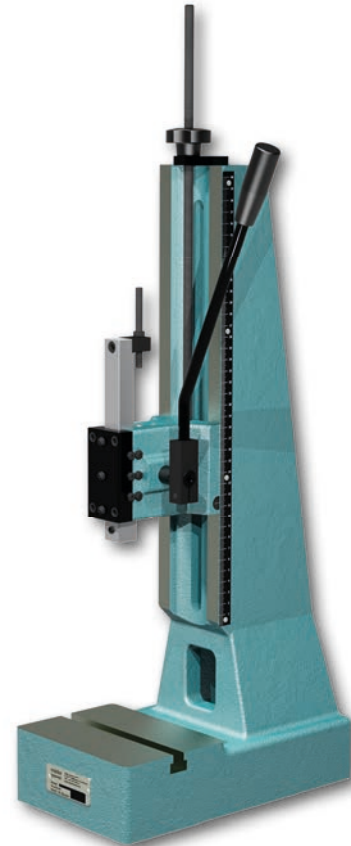

L-VZ 250-50

Rack and pinion presses

Type			VZ 150-40	VZ 150-90	VZ 250-50	VZ 250-100	L-VZ 250-50	L-VZ 250-100
Capacity		kN	1.5	1.5	2.5	2.5	2.5	2.5
Working stroke		mm	40	90	50	100	50	100
Throat	A	mm	63	63	80	80	80	80
Daylight	B	mm	35 - 235	35 - 235	42 - 290	42 - 290	55 - 390	55 - 390
Table size	CxD	mm	110 x 65	110 x 65	157 x 115	157 x 115	157 x 115	157 x 115
T-slot width similar to DIN 650		mm	10	10	12	12	12	12
Ram bore Ø x Depth	E	mm	10H7 x 25	10H7 x 25	10H7 x 25	10H7 x 25	10H7 x 25	10H7 x 25
Ram Ø	F	mm	20 x 20	20 x 20	20 x 20	20 x 20	20 x 20	20 x 20
Space requirement	CxG	mm	110 x 164	110 x 164	157 x 237	157 x 237	156 x 275	156 x 275
Stand height	K	mm	355	355	450	450	570	570
Weight		kg	ca. 8.5	ca. 8.5	ca. 21	ca. 21	ca. 29	ca. 29

Accessories (see Page 8-9)	Please specify when ordering.						
Return travel lock	HS	HS	HS	HS	HS	HS	HS
Micrometer stop	MICRO	MICRO	MICRO	MICRO	MICRO	MICRO	MICRO
Counter	Z	Z	Z	Z	Z	Z	Z
Table bore 12 ^{H7}	TB	TB	TB	TB	TB	TB	TB
Left/right-hander version*	R/L	R/L	R/L	R/L	R/L	R/L	R/L

* Can only be combined with the MICRO and TB accessories.

** Not included. Accessories must be ordered separately.

The accessories

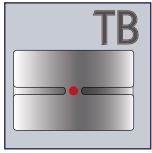

The MicroPress® rack and pinion press is particularly suitable for precise fitting work in light engineering, where the force needed is low but where the operator wants to work sensitively.

The advantages:

- ▶ Press table with T-slot as standard in scope of supply
- ▶ Alternatively, press tables with table bore TB or in flat version or to customer specification can be supplied.
- ▶ Quickly and easily converted from right-handed to left-handed operation.
- ▶ Adjustable daylight
- ▶ Precise guidance of ram
- ▶ Cushioned return stroke
- ▶ Stroke length adjustable
- ▶ Hand lever adjustable over 360°
- ▶ Lightweight design

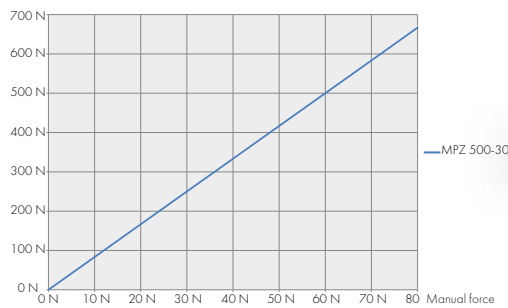

Rack and pinion press
MPZ 500-30



Manual lever can be refitted for right and left-handers

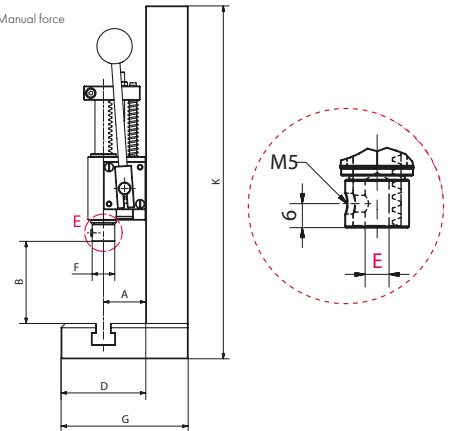

Standard

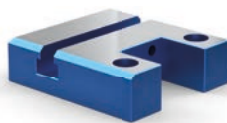
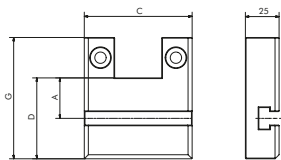

Table 1

Accessories*

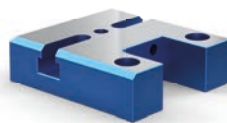
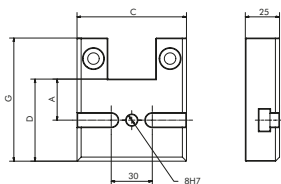

Table 2

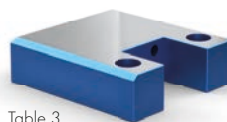
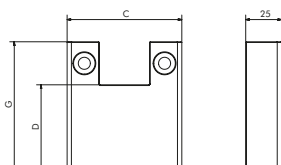

Table 3

Type			MPZ 500-30
Capacity		N	500
Working stroke		mm	25
Throat	A	mm	30
Daylight	B	mm	25 - 150
Table size	CxD	mm	80 x 60
T-slot width similar to DIN 650	E	mm	6H7 x 12
Ram Ø	F	mm	16
Space requirement	CxG	mm	80 x 90
Stand height		mm	250
Weight		kg	ca. 1.5
Tabletop			
Table 1 T-slot width similar to DIN 650		mm	10
Table 2 T-slot with TB		mm	8H7
Table 3 plan			

*Not included. Accessories must be ordered separately.

Request CAD at www.maederpressen.de or directly from Tel.+49 (0) 74 67 - 94 67 - 0

Rack and pinion press

The Micro HP 40 press represents the classic watchmaker's rack and pinion press. Its small and compact design permits precise and sensitive work in the lower force segment. The table bore is aligned with the ram bore, permitting both fast and precise tool change. This is an advantage for small runs or one-off part production.

The advantages:

- ▶ Stroke length infinitely adjustable
- ▶ Precise guidance of ram
- ▶ Hand lever freely positionable

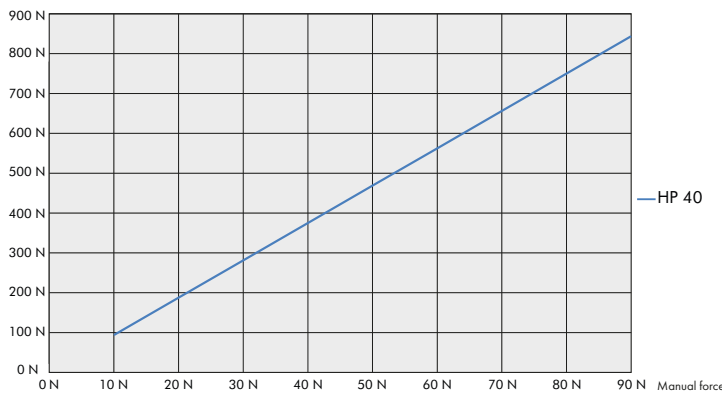

Rack and pinion press
HP 40

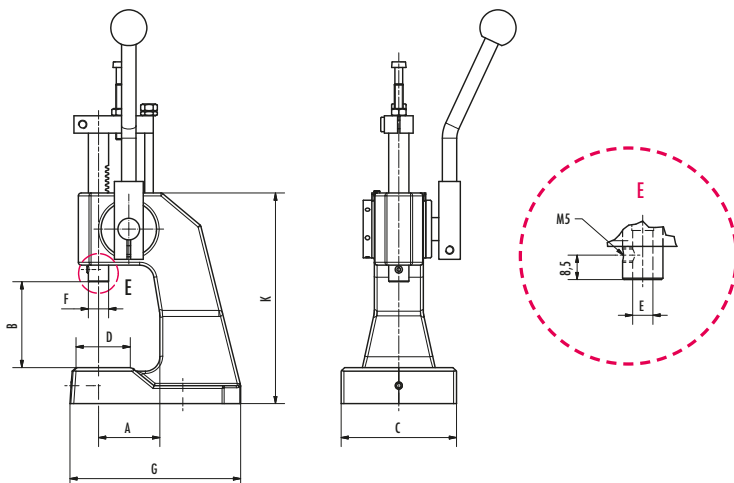

Type			HP 40
Capacity		N	750
Working stroke		mm	35
Throat	A	mm	40
Daylight	B	mm	60
Table size	CxD	mm	80 x 35
T-slot width similar to DIN 650	E	mm	7H7 x 20
Ram Ø	F	mm	14
Space requirement		mm	12H7
Thread in table		mm	2 x M6
Thread distance		mm	50
Space requirement	CxG	mm	80 x 118
Stand height	K	mm	149
Weight		kg	ca. 4,0

Rack and pinion press

Low-cost monitoring and logging of pressing processes with mäder hand presses.



- Can be fitted to all mäder hand presses
- Intelligent sensors, automatic recognition of sensor values
- Auto-configuration of the measurement program with the master-card
- Easy, one-button operation
- 2 line, easy read display
- Bright OK /NOK displays
- Adjustable alarm tone
- Diverse counter functions
- One channel measurement (force only) possible

Options:

- Measurement logging via USB interface
- Tool card for storing and setting tool-specific measurement data
- Cam PLC operation
- PLC card for storing and setting programs.



The TPC ForceMaster can be set up quickly and easily:

Sensor detection

The connectors of the force and displacement sensors are not interchangeable, and are therefore protected from false connections. The characteristics of the sensor are already stored on a printed circuit board in the connector plug. When the TPC ForceMaster is switched on, the sensors are automatically detected and the zero point determined. If the sensors are exchanged, the sensor change will be shown in the display and must be confirmed.

Auto-configuration

The TPC ForceMaster creates a process monitoring proposal, based on a one-time teach-in process of a good part. This proposal can either be accepted or modified manually on the device or with the help of the supplied software. A good part consists of parts which were checked before the pressing process as to whether they are within the manufacturing tolerances and from which it can therefore be expected that the process will in turn manufacture a good part.

Evaluation variants

Threading

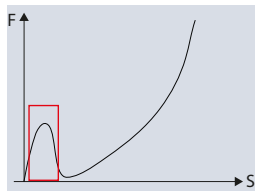

The threading area performs a check to determine whether the maximum force will be exceeded at the start of a joining process. An alarm will notify a warning that parts or the tool could possibly be damaged. The threading area must be activated.

Gates

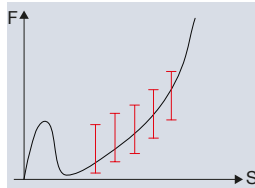

With the auto-configuration, 5 gates will be activated. A gate is defined by a path position and a minimum and maximum force. The forced-displacement curve for good parts must run through all the gates, and no gate may be circumvented. The evaluation is performed when the press stroke has exceeded the path position of all the gates.

Force thresholds

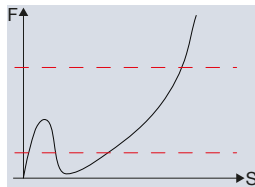

Force thresholds define a minimum force to be achieved and a maximum force threshold, within which the entire force fitting process must be performed once the minimum force has been reached.

Block area End position

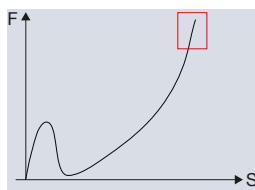

Often the force fitting process is concluded with a high force exertion at the end of the stroke: the block area. It is defined by a force and displacement range which may not be under-run or exceeded. The block area is always inactive after the auto-configuration and must be activated as required.

Press-fit stem path

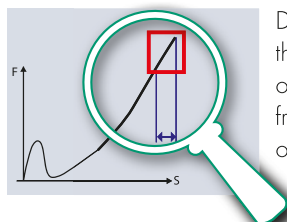

During the deformation processes which occur at the end of the stroke, the press-fit stem path can also be monitored. The press-fit stem path monitoring can only be activated with an active block area. The press-fit stem path is calculated from the path differential between the reaching of the block area and the beginning of the return stroke.

Force alarm

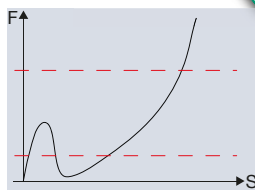

Force alarms are used to monitor the force sensor and will not lead to an NOK rating. There is a top and bottom force alarm available. Force alarms can, for example, be used to perform switching functions.

OK/NOK notifications

The ForceMaster confirms the manufacturing of an OK part with a green indicator light. A NOK part is notified with a pre-settable signal tone and a red indicator light. By default, the TPC ForceMaster is pre-set in such a manner that the NOK message can only be acknowledged with a master-card. In the manual configuration of the measurement program, this feature can be disabled.

ForceMaster structural layout

From left to right:

- ▶ Card slot
- ▶ Speaker
- ▶ OK / NOK indicator lights
- ▶ Rotary pushbutton for programming



Counter

Six different counter types can be set via the configuration menu:

- ▶ OK parts
- ▶ NOK parts
- ▶ Total of all parts
- ▶ Count down counter
- ▶ R-set (set value for countdown counter)
- ▶ Total stroke counter

Software

The software for the visualisation and correction of the auto-configuration is included in the scope of delivery.

Options:

USB interface for a USB stick

The graphical curve data can be stored on a USB stick for documentation and evaluation purposes. The cycle time should be ≥ 3 seconds.

Cam PLC

The cam PLC functions in the same manner as an electronic, path-controlled step chain controller. When a cam is reached, the movement direction of the press ram is also evaluated. This enables the programming of an action in the cam area, which is dependent on the work or return stroke. This is based on a step chain control, which sequentially performs an array of processes. Only when a condition is fulfilled will an action be executed and a jump to the next step be performed.

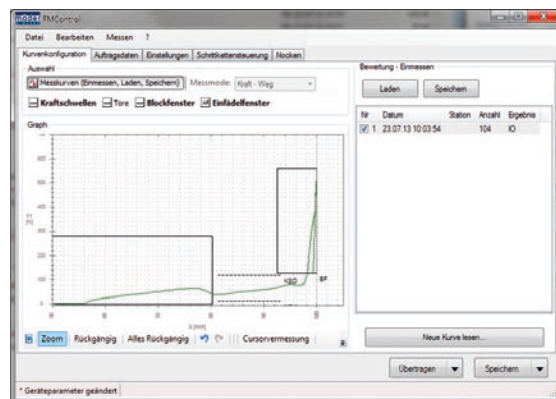

There are 8 inputs and 8 outputs available for programming. The cam PLC can not be used for press-safety purposes.

SmartCards

- Tool card
- PLC card

Single-dimensional operation

It is also possible to operate the TPC ForceMaster with the force sensor only.

TPC ForceMaster Technical Data

General device data	
Display:	2-line backlit LCD display
Warning and acknowledgement sounds:	type of signal can be set
Warning sound volume:	up to 100 dB
Measuring channels:	force/displacement or force/time
Communication interfaces:	USB - Type B slave port, on the rear side RS232 - D-SUB 9, data rate 19.2 kbps
Interface:	USB, RS232
Measurement error:	0.5% from calibration
Electrical connection:	90 ... 240 V AC / 50 ... 60 Hz
Cut-off frequency:	1 kHz
Working temperature range:	0 ... 60 °C
Humidity:	10 ... 80%, non-condensing
Housing:	aluminium profile housing
Protection class:	IP20
Connections:	coded special connectors
Sampling rate:	10 kHz
Number of I/O:	8 inputs / 8 outputs
Dimensions (W x H x D):	150 x 95 x 260 [mm]
Weight: approx.	3 kg

TPC ForceMaster sensors

Load cell for TPC ForceMaster

- The ideal, user-friendly force sensors for hand lever presses.
Cross-thread for the tool attachment.
- By means of the clamping spigot, the sensor can be inserted into the ram bore of the press can be attached.
- The tool is mounted in the mounting hole of the sensor. and fastened with an Allen screw in the transverse thread.

Overall measurement error:	<± 1% from calibration
Maximum usage force:	approx. 120% of the rated power
Protection class:	according to EN 60529: IP54
Diameter:	50 mm
Height without clamping pin:	50 mm
Clamping pin diameter:	10 ^{H7} x 21 mm
Sensor bore (diameter x depth):	10 ^{H7} x 25 mm
The sensor must not be subjected to lateral forces.	

Potentiometer

Linearity deviation:	from 0.1% from calibration
Resolution:	0.01 mm
Protection class according to EN 60529:	IP 40

Retrofit kit for potentiometer

Existing hand lever presses can be retrofitted with a potentiometer with the retrofit kit. An illustration with the drilling pattern is included.



Measurement ranges	Max. overload
0 - 100 N	1 kN
0 - 250 N	2.5 kN
0 - 0.5 kN	5 kN
0 - 1.0 kN	10 kN
0 - 2.5 kN	25 kN
0 - 5.0 kN	30 kN
0 - 10.0 kN	30 kN
0 - 25.0 kN	30 kN



Tandheugelpersen brengen gedurende de gehele slag de (hand)kracht gelijkmatig over.

De voordelen:

- Goed gevoel in verband met directe overbrenging
- Diepte-instelling slag instelbaar met schroefdraad
- Ergonomisch vanwege instelbare handel.
- Nauwkeurig gefreesd tafelbed incl. 2 bevestigingspunten t.b.v. werkstukken.
- Boring tafelbed geeft vele mogelijkheden

Ideaal geschikt voor gevoelige inpers- en buigwerkzaamheden.



CL 150 Z
1,5 kN

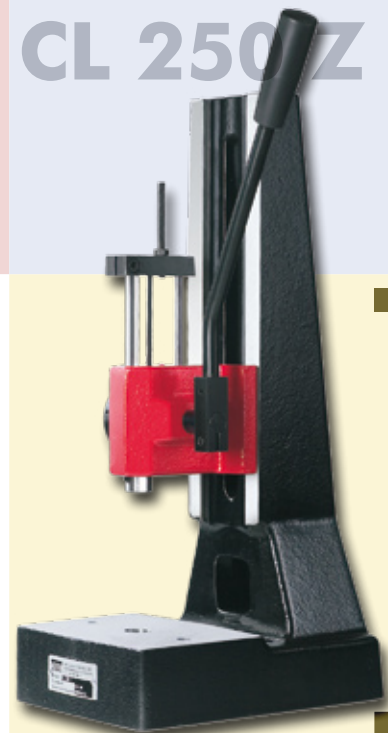

CL 250 Z
2,5 kN

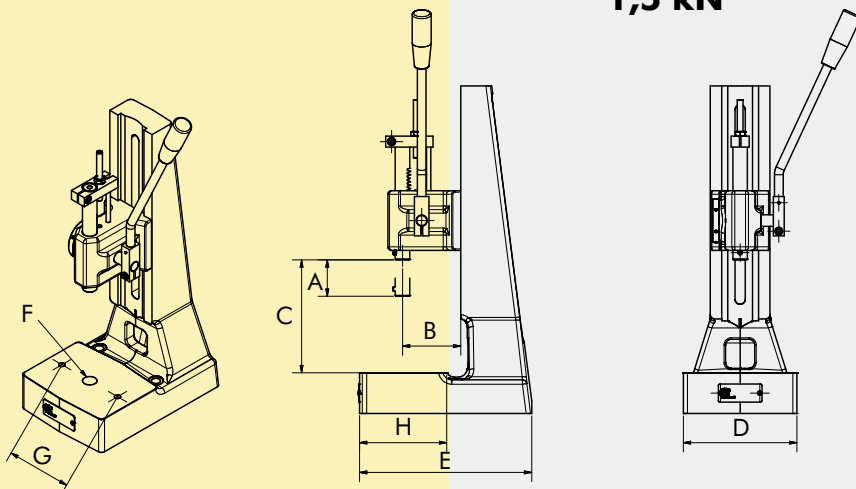

Type			CL 150 Z	CL 250 Z
Perskracht	kN		1,5	2,5
Arbeidsslag	mm	A	40	50
Uitlading	mm	B	63	80
Werkhoogte	mm	C	50-240	45-295
Afm. tafelbed	mm	DxH	110x60	157x115
Boring tafelbed Ø	mm	F	20	20
Bevestigingsgaten	mm		2 x M 8	2 x M 10
Afstand schroefdraad	mm	G	66	108
Boring ram Ø x diepte	mm		10 ^{H7} x 25	10 ^{H7} x 25
Ram Ø	mm		20	20
Benodigde ruimte	mm	DxE	110x160	157x237
Gewicht	ca. kg		7,5	20,5

CAD-bestanden zijn op aanvraag beschikbaar

