

Works. Simple.  
Reliable.

mäder  
pressen

# press workstations

Configure your workplace - individually  
according to your requirements:

## mäder press



- control
- process monitoring
- workbench + enclosure
- light curtain/safety door
- pressing tool
- sliding table

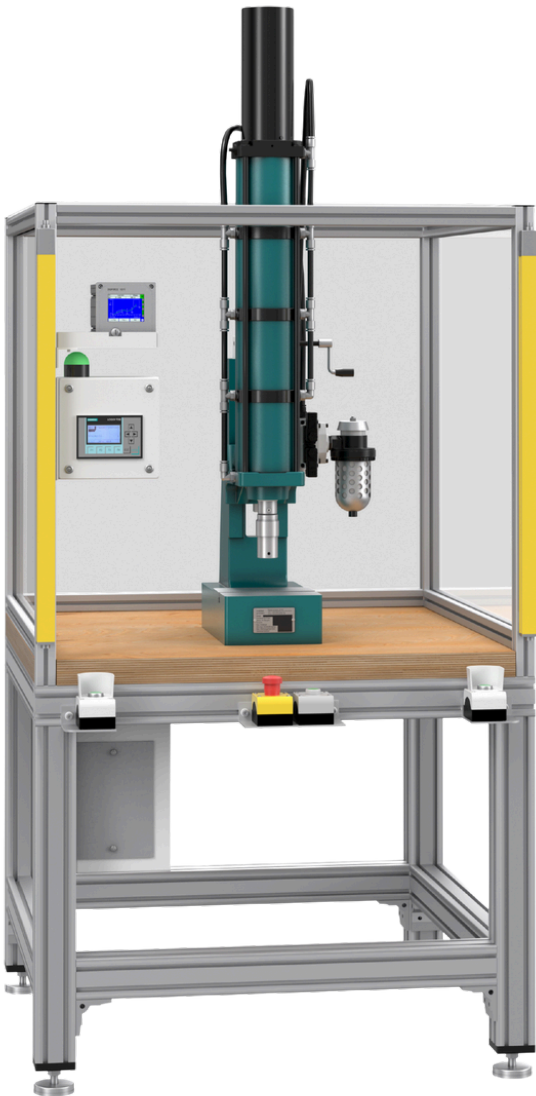

## 2-hand safety control

The **MPS-2 two-hand safety control** for pneumatic presses includes

- a press safety valve,
- maintenance unit,
- push button with protective collar,
- PLC with free interfaces,
- Ethernet interface,
- an integrated web server for remote maintenance,
- an insert for standard micro SD cards and
- an electronic stroke counter.

The control system is optionally available with the following functions:

- stop time function,
- control of a sliding table,
- process monitoring

**Customised solutions** are our strength!



## Process monitoring

The TPC-Midi **process monitoring system** enables joining and assembly processes to be monitored reliably. The system consists of a

- control unit,
- force and displacement sensors,
- an evaluation unit and
- optional software.

Sixteen different measurement programmes can be stored in the device, offering a wide range of evaluation options (e.g. windows, thresholds, envelopes, etc.).

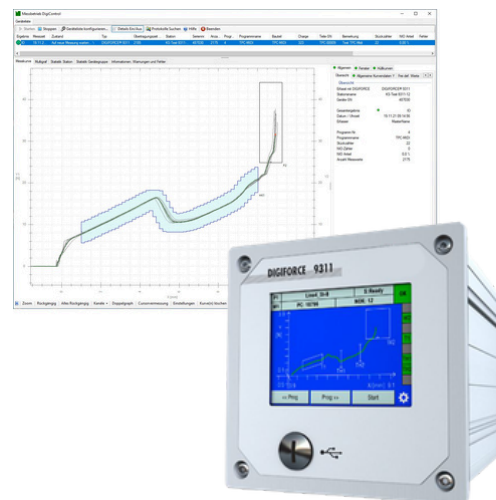

**TPC-Midi monitors the press-fit process, compares the actual progress with the specifications and then evaluates it. Rejected parts are thus reliably detected and can be sorted out.**

## workbench + enclosure

Our standard **enclosures with workbenches** are available in various widths.

The following optional features are available:

- Standing or seated workstation, height-adjustable on request
- Integrated LED lighting
- Drawers
- Foldable castors
- Enclosure made of Makrolon or metal mesh

Every workbench and enclosure can be **individually adapted to your requirements!**

## light curtain or safety door

To **protect operating personnel** from possible injuries when entering the danger zone, the press assembly area can be safely shielded using light curtains or safety doors.

- **Light curtains** are available with performance level PL e.
- The **safety doors** can be operated **manually, pneumatically or electrically**, depending on the specific process.

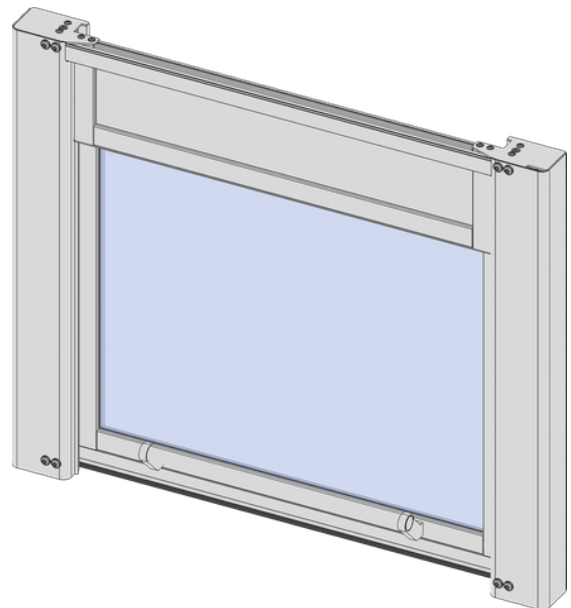

## Press tool according to drawing

**Customised pressing tools** are manufactured according to your drawings, sample parts or specific requirements. We develop solutions together in **personal discussions**, **online meetings** or directly during **practical tests** on our test presses.

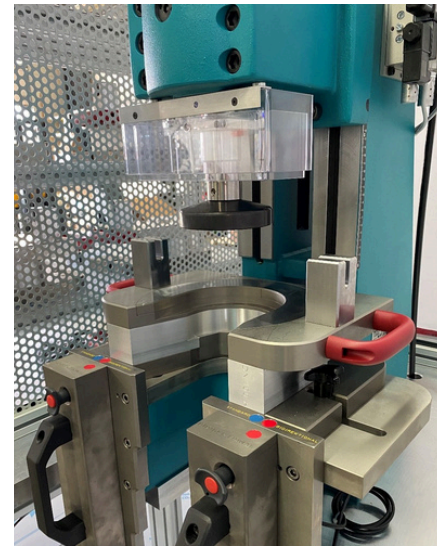
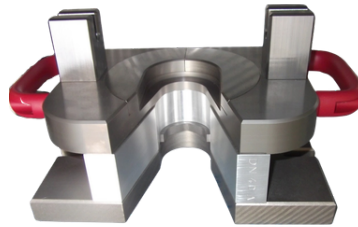
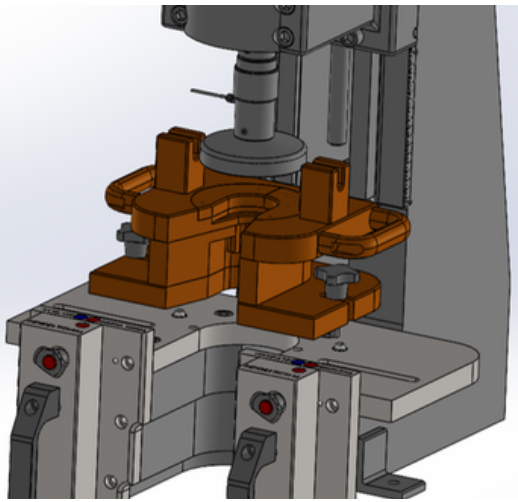

## sliding table

The following sliding tables are available as standard for precise **positioning and insertion of the workpiece** outside the danger zone:

- **Manual** sliding table MST 80 / MST 100 / MST 130 with 80, 100 or 130 mm stroke
- **Pneumatic** sliding table PST 130 with 130 mm stroke

