

DA range

DA presses are the logical implementation of modern press technology for direct-acting pneumatic presses. Due to their modular design, exactly the size needed for the application can be selected, thus optimising the price/performance ratio. Standard stroke lengths from 40 mm to 120 mm are available in 20 mm steps. Special lengths can be provided on request. Direct-acting pneumatic presses produce a constant force over the whole stroke length. All direct-acting pneumatic presses can be provided as automation components or with **mäder** controllers for individual workstations.

The processing of sheet metal, printed circuit boards and other bulky components requires presses to have a larger throat. XL-DA presses with 250 mm and 300 mm throat enable even these workpieces to be processed.

L-DA presses with up to 350 mm daylight are used for tall parts which require more vertical space. For dimensions which lie outside the standard, presses with press frames in welded design can be manufactured to your specifications.

DA presses are practically maintenance-free, as all moving parts are mounted in bearings. Cylinders are pre-greased and are therefore suitable for oil-free operation.

Quality features:

- ▶ Anti-twist, hard-chrome-plated ram guided in Teflon bushes
- ▶ Simple adjustment of the height of the press head using a threaded spindle and right-angle gearbox
- ▶ Side-mounted measuring strip for fast reproduction of settings when changing the tool
- ▶ Practically maintenance-free double-acting cylinder
- ▶ Adjustable cylinder end-position damping
- ▶ Low noise: less than 75 dB





Sensors are not included

Adjusting the stroke of DA presses

DA presses are fitted as standard with an innovative, precise and easy-to-use system which enables accurate stroke adjustment and protects the ram against twisting.

Operation:

- ▶ The press depth can be adjusted to a reading accuracy of 0.01 mm over the whole stroke length with only one scale nut (A). The stroke length can be read off using the side scale (B) and the vernier on the scale nut (A).
- ▶ The position of the ram can be checked by means of reed contacts (C) which are slid onto the standard scale.
- ▶ The sensors do not have to be readjusted when the stroke length is changed, as the stroke length control magnets always move to the same end positions.

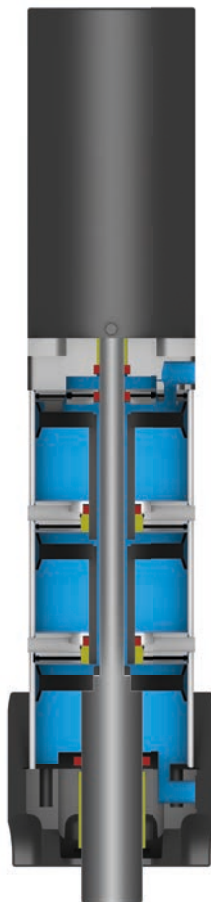

Tandem cylinders

The energy-efficient tandem cylinder design is used for larger forces. Several pneumatic cylinders are connected in tandem, thus increasing the force of the cylinder accordingly. The air consumption is optimised, as the return stroke is only via one cylinder chamber. The press can be operated using only two air connections, as the air is channelled within the pneumatic cylinder.

The accessories

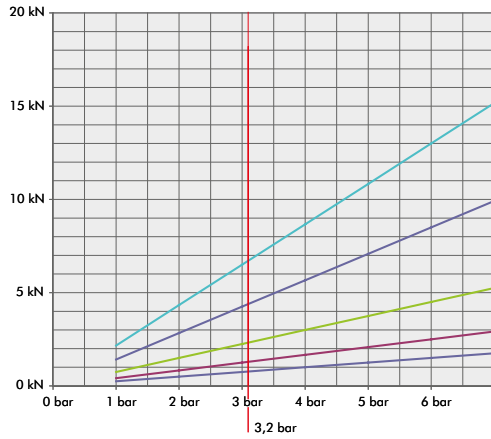
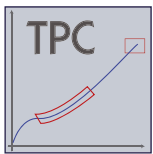
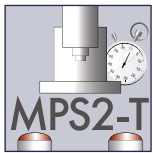
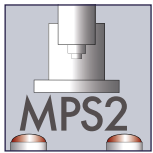
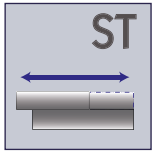
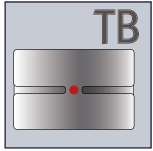

- DA 1300-*-80
- DA 850-*-80
- DA 450-*-80
- DA 250-80-80
- DA 150-80-63

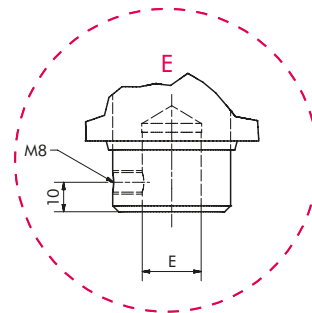
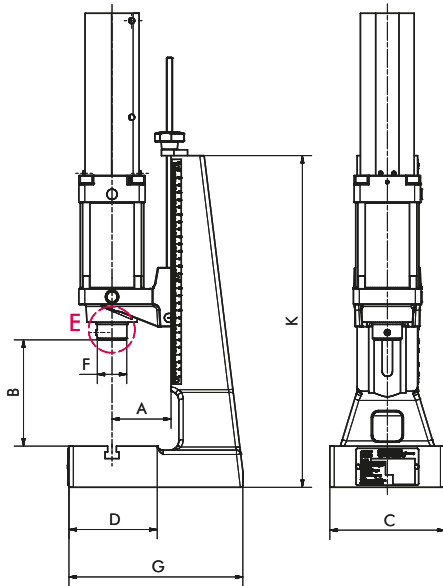

For details of fine stroke adjustment see page 37.

DA Series with round ram
L-DA Series with round ram, daylight 350 mm

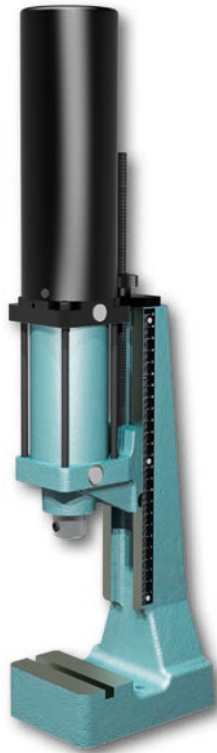

DA 150-80-63

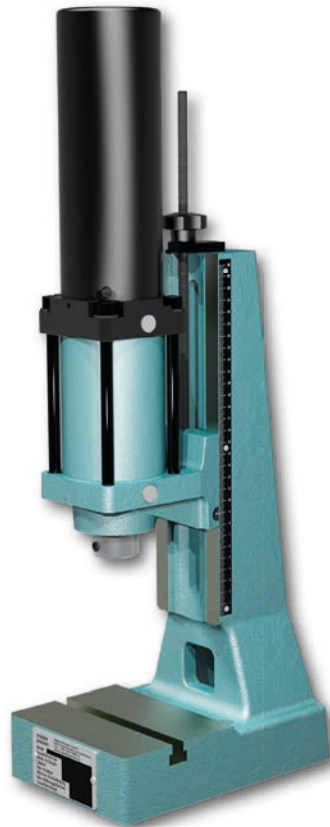

DA 250-80-80

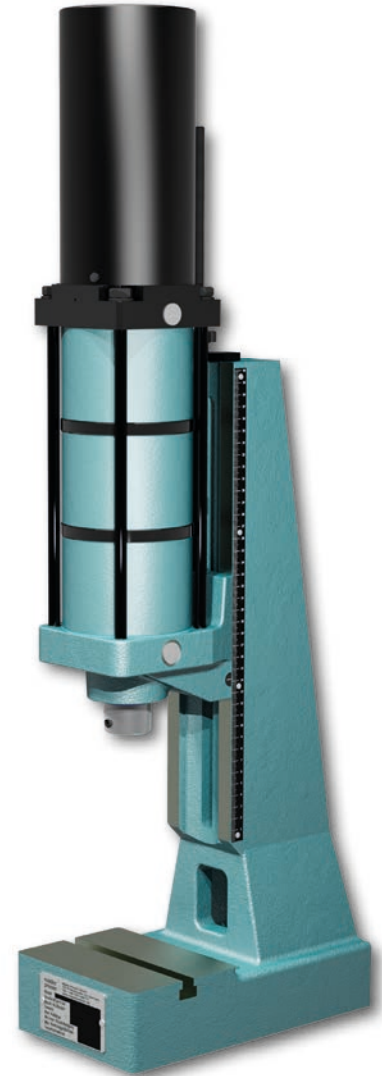

L-DA 1300-40-80

Direct-acting pneumatic presses

Type			DA 150-80-63	DA 250-80-80	L-DA 250-80-80	DA 450- [*] -80	L-DA 450- [*] -80	DA 850- [*] -80	L-DA 850- [*] -80	L-DA 1300- [*] -80
Capacity at 6 bar		kN	1.5	2.5	2.5	4.5	4.5	8.5	8.5	13
Working stroke max. *		mm	80	80	80	40/60/80/ 100/120	40/60/80/ 100/120	40/60/80/ 100/120	40/60/80/ 100/120	40/60/80/ 100/120
Throat	A	mm	63	80	80	80	80	80	80	80
Daylight	B	mm	40 - 215	70 - 280	65 - 390	58 - 243	65 - 350	58 - 243	65 - 350	65 - 350
Table size	CxD	mm	100 x 65	157 x 115	157 x 115	157 x 115	157 x 115	157 x 115	157 x 115	157 x 115
T-slot width similar to DIN 650		mm	10	12	12	12	12	12	12	12
Ram bore Ø x Depth	E	mm	16H7 x 25	20H7 x 25	20H7 x 25	20H7 x 25	20H7 x 25	20H7 x 25	20H7 x 25	20H7 x 25
Ram Ø	F	mm	30	40	40	40	40	40	40	40
Air connection			G 1/4"	G 1/4"	G 1/4"	G 3/8"	G 3/8"	G 3/8"	G 3/8"	G 3/8"
Air consumption/cm cyl. stroke		l	0.2	0.3	0.3	1.0	1.0	1.5	1.5	2.1
Space requirement	CxG	mm	110 x 164	157 x 237	155 x 280	155 x 237	156 x 275	155 x 237	156 x 275	156 x 275
Stand height	K	mm	355	450	570	450	570	450	570	570
Weight		kg	ca. 11.5	ca. 25	ca. 31	ca. 28	ca. 34	ca. 31	ca. 37	ca. 40

Extras (siehe Seite 8)	Please specify when ordering.									
Table bore 12 ^{H7}	TB	TB	TB	TB	TB	TB	TB	TB	TB	TB

* Specify the stroke length when ordering.

Valve and service unit only included with controller. Design may vary.

The accessories

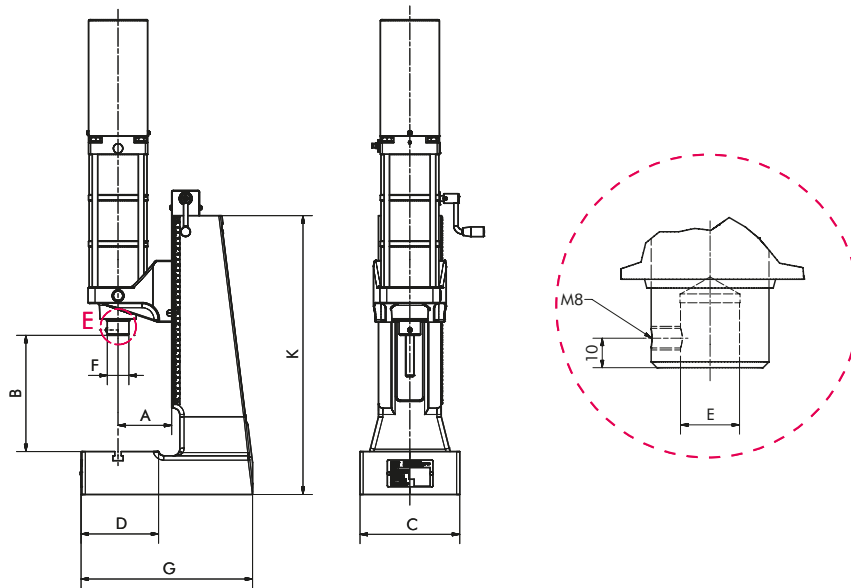
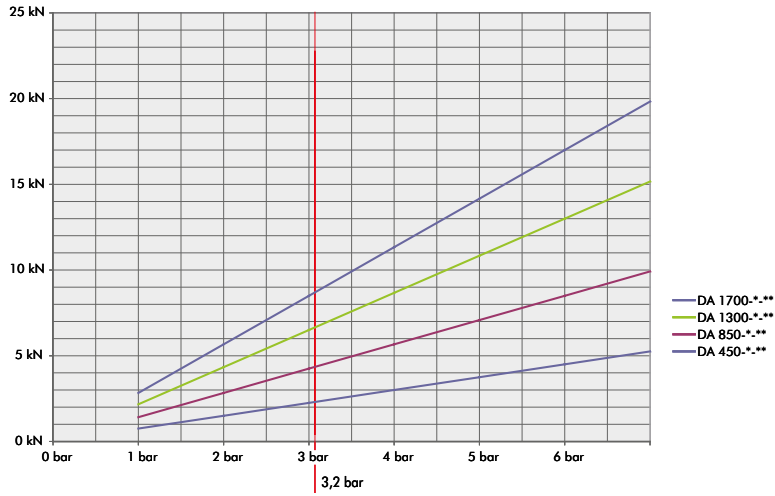
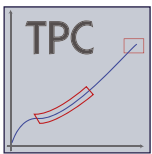
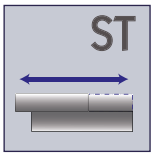
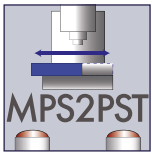
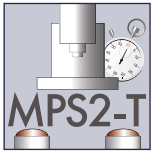
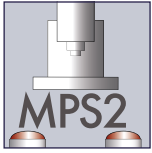

For details of fine stroke adjustment see page 37

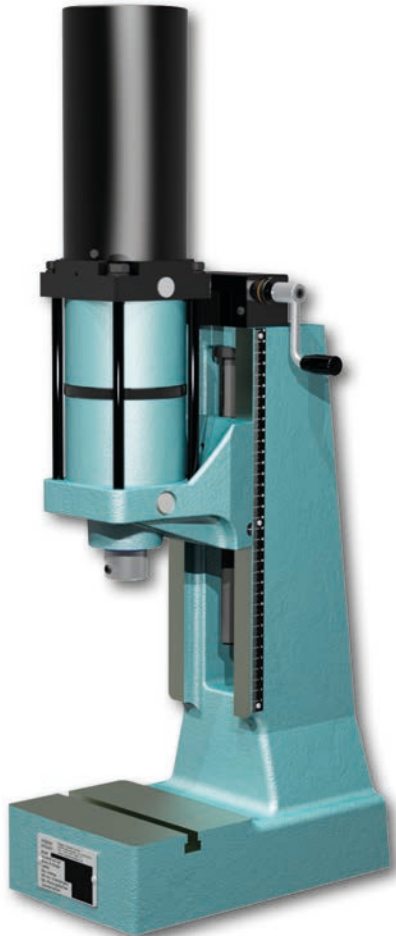

DA 850-40-100

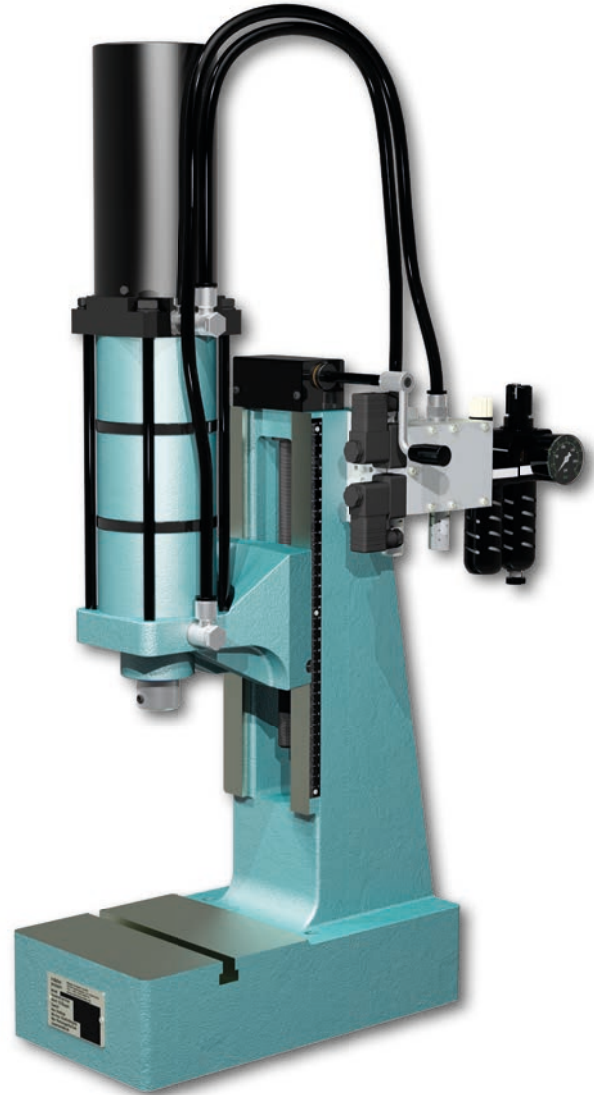

DA 1300-40-130

Direct-acting pneumatic presses

Type			DA 450-*.100	DA 850-*.100	DA 1300-*.100	DA 1700-*.100
Capacity at 6 bar		kN	4.5	8.5	13.0	17.0
Working stroke max. *		mm	40/60/80/ 100/120	40/60/80/ 100/120	40/60/80/ 100/120	40/60/80/ 100/120
Throat	A	mm	100	100	100	100
Daylight	B	mm	60 - 285	60 - 285	60 - 285	60 - 285
Table size	CxD	mm	185 x 145	185 x 145	185 x 145	185 x 145
T-slot width similar to DIN 650		mm	12	12	12	12
Ram bore Ø x Depth	E	mm	20H7 x 25	20H7 x 25	20H7 x 25	20H7 x 25
Ram Ø	F	mm	40	40	40	40
Air connection			G 3/8"	G 3/8"	G 3/8"	G 3/8"
Air consumption/cm Cyl. stroke		l	1.0	1.5	2.1	2.6
Space requirement	CxG	mm	185 x 320	185 x 320	185 x 320	185 x 320
Stand height	K	mm	520	520	520	520
Weight		kg	ca. 62	ca. 65	ca. 68	ca. 71

	DA 450-*.130	DA 850-*.130	DA 1300-*.130	DA 1700-*.130
Capacity at 6 bar	4.5	8.5	13.0	17.0
Working stroke max. *	40/60/80/ 100/120	40/60/80/ 100/120	40/60/80/ 100/120	40/60/80/ 100/120
Throat	130	130	130	130
Daylight	70 - 325	70 - 325	70 - 325	70 - 325
Table size	200 x 190	200 x 190	200 x 190	200 x 190
T-slot width similar to DIN 650	14	14	14	14
Ram bore Ø x Depth	20H7 x 25	20H7 x 25	20H7 x 25	20H7 x 25
Ram Ø	40	40	40	40
Air connection	G 3/8"	G 3/8"	G 3/8"	G 3/8"
Air consumption/cm Cyl. stroke	1.0	1.5	2.1	2.6
Space requirement	200 x 385	200 x 385	200 x 385	200 x 385
Stand height	580	580	580	580
Weight	ca. 77	ca. 80	ca. 83	ca. 86

* Specify the stroke length when ordering.

Valve and service unit only included with controller. Design may vary.

The accessories

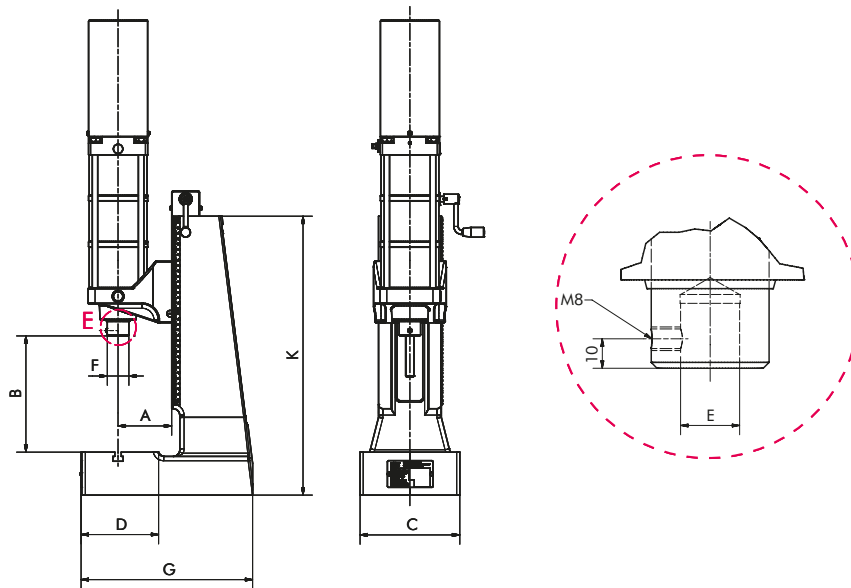
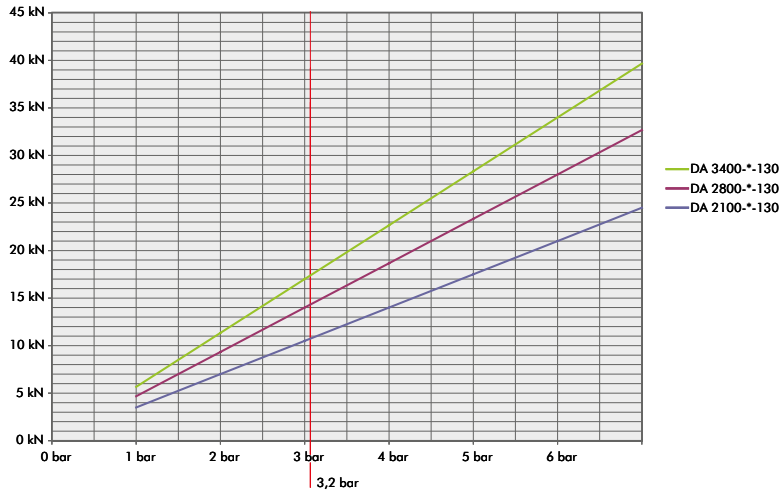
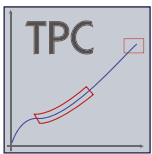
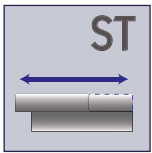
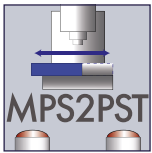
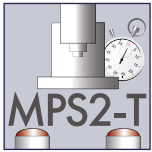
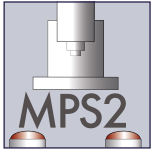

For details of fine stroke adjustment see page 37



DA 3400-40-130

Direct-acting pneumatic presses

Type			DA 2100- *-130	DA 2800- *-130	DA 3400- *-130
Capacity at 6 bar		kN	21.0	28.0	34.0
Working stroke max. *		mm	40/60/80/100/120	40/60/80/100/120	40/60/80/100/120
Throat	A	mm	130	130	130
Daylight	B	mm	75 - 330	75 - 330	75 - 330
Table size	CxD	mm	200 x 190	200 x 190	200 x 190
T-slot width similar to DIN 650		mm	14	14	14
Ram bore Ø x Depth	E	mm	20H7 x 25	20H7 x 25	20H7 x 25
Ram Ø	F	mm	40	40	40
Air connection			G 3/8"	G 3/8"	G 3/8"
Air consumption/cm cyl. stroke		l	3.0	3.7	4.5
Space requirement	CxG	mm	200 x 385	200 x 385	200 x 385
Stand height	K	mm	580	580	580
Weight		kg	ca. 92	ca. 99	ca. 105

* Specify the stroke length when ordering.

Valve and service unit only included with controller. Design may vary.

The accessories

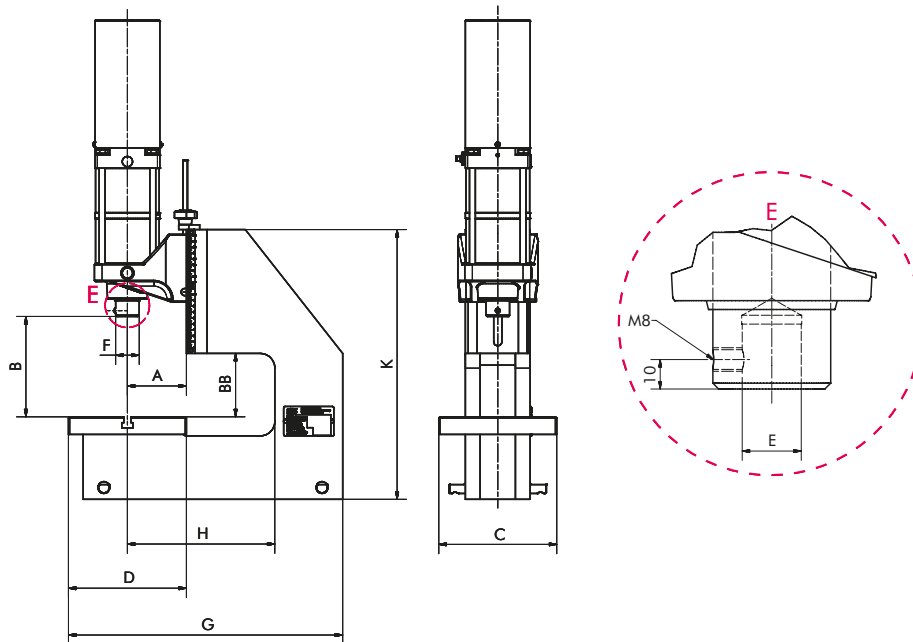
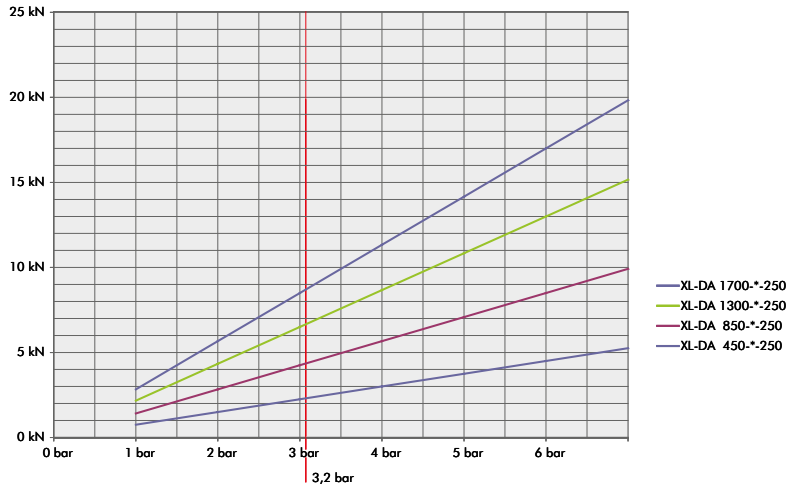
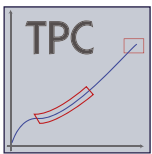
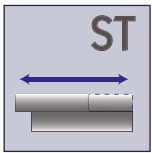
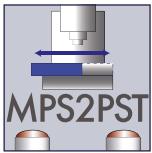
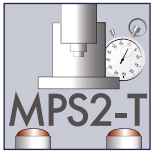
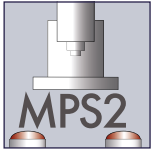

For details of fine stroke adjustment see page 37

XL- Direct-acting pneumatic presses
DA-Serie with round ram, with 250 mm throat



XL-DA 1300-40-250

Type			XL-DA 450*-250	XL-DA 850*-250	XL-DA 1300*-250	XL-DA 1700*-250
Capacity at 6 bar		kN	4.5	8.5	13.0	17.0
Working stroke max. *		mm	40/60/80/100/120	40/60/80/100/120	40/60/80/100/120	40/60/80/100/120
Throat	A	mm	100	100	100	100
Throat C-frame	H	mm	250	250	250	250
Daylight	B	mm	75 - 175	75 - 175	75 - 175	75 - 175
Daylight C-frame	BB	mm	100	100	100	100
Table size	CxD	mm	200 x 200	200 x 200	200 x 200	200 x 200
T-slot width similar to DIN 650		mm	12	12	12	12
Ram bore Ø x Depth	E	mm	20H7 x 25	20H7 x 25	20H7 x 25	20H7 x 25
Ram Ø	F	mm	40	40	40	40
Air connection			G 3/8"	G 3/8"	G 3/8"	G 3/8"
Air consumption/cm cyl. stroke		l	1.0	1.5	2.1	2.6
Space requirement	CxG	mm	200 x 465	200 x 465	200 x 465	200 x 465
Stand height	K	mm	465	465	465	465
Weight		kg	ca. 57	ca. 60	ca. 63	ca. 66

* Specify the stroke length when ordering.

Valve and service unit only included with controller. Design may vary.

The accessories

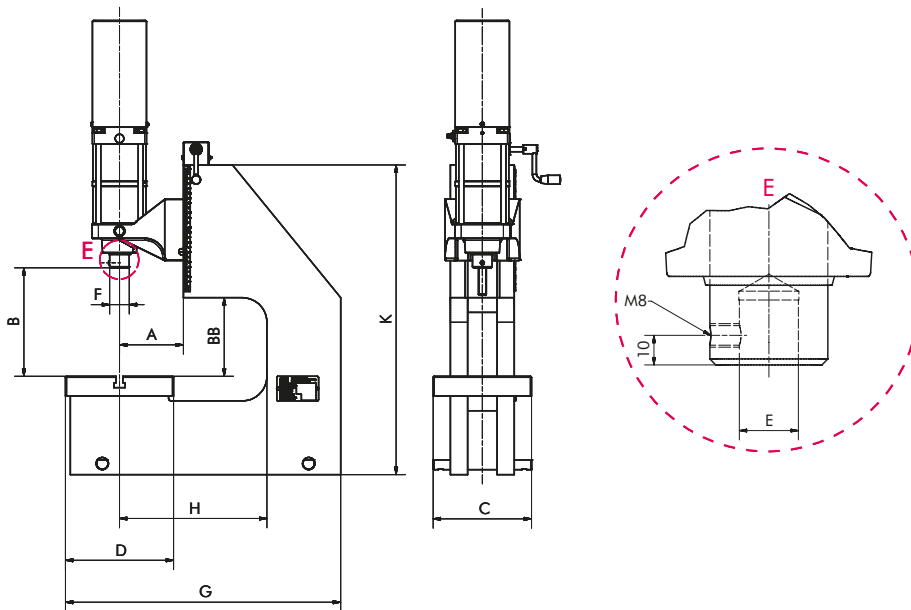
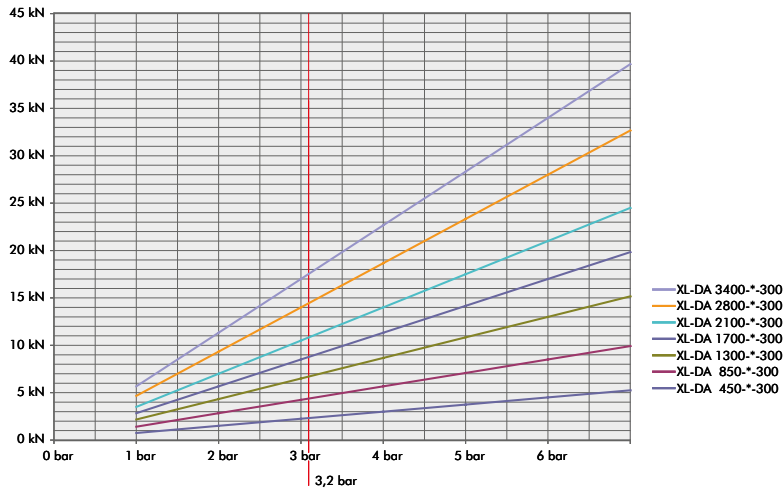
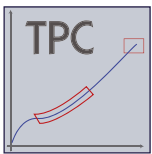
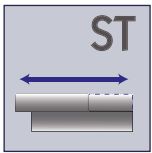
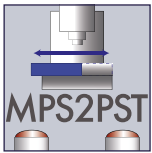
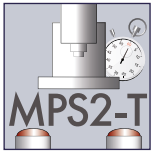
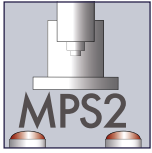

For details of fine stroke adjustment see page 37.

XL- Direct-acting pneumatic presses
DA-Series with round ram, with 300 mm throat



XL-DA 2800-40-300

Direct-acting pneumatic presses

Type			XL-DA 450*-300	XL-DA 850*-300	XL-DA 1300*-300	XL-DA 1700*-300	XL-DA 2100*-300	XL-DA 2800*-300	XL-DA 3400*-300
Capacity at 6 bar		kN	4.5	8.5	13.0	17.0	21.0	28.0	34.0
Working stroke max.*		mm	40/60/80/100/120	40/60/80/100/120	40/60/80/100/120	40/60/80/100/120	40/60/80/100/120	40/60/80/100/120	40/60/80/100/120
Throat	A	mm	130	130	130	130	130	130	130
Throat C-frame	H	mm	300	300	300	300	300	300	300
Daylight	B	mm	140 - 275	140 - 275	140 - 275	140 - 275	130 - 275	130 - 275	130 - 275
Daylight C-frame	BB	mm	158	158	158	158	158	158	158
Table size	CxD	mm	200 x 220	200 x 220	200 x 220	200 x 220	200 x 220	200 x 220	200 x 220
T-slot width similar to DIN 650		mm	14	14	14	14	14	14	14
Ram bore Ø x Depth	E	mm	20H7 x 25	20H7 x 25	20H7 x 25	20H7 x 25	20H7 x 25	20H7 x 25	20H7 x 25
Ram Ø	F	mm	40	40	40	40	40	40	40
Air connection			G 3/8"	G 3/8"	G 3/8"	G 3/8"	G 3/8"	G 3/8"	G 3/8"
Air consumption/cm Cyl. stroke		l	1.0	1.5	2.1	2.6	3.0	3.7	4.5
Space requirement	CxG	mm	200 x 560	200 x 560	200 x 560	200 x 560	200 x 560	200 x 560	200 x 560
Stand height	K	mm	630	630	630	630	630	630	630
Weight		kg	ca. 135	ca. 138	ca. 141	ca. 144	ca. 141	ca. 158	ca. 164

* Specify the stroke length when ordering.

Valve and service unit only included with controller. Design may vary.

The accessories

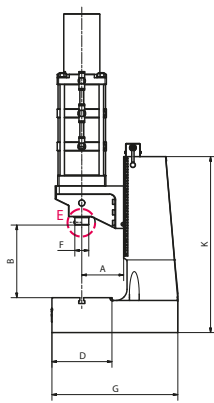
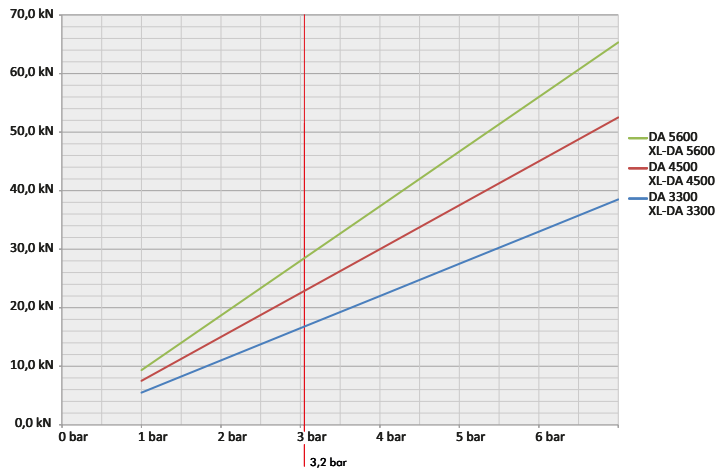
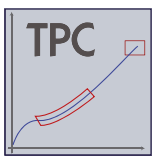
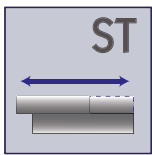
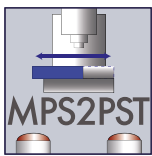
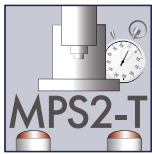
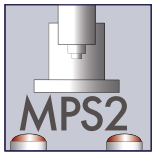

DA Type

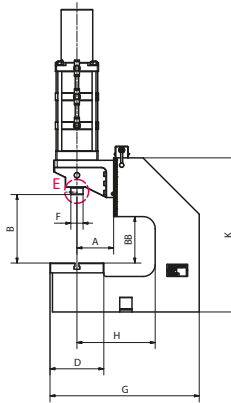
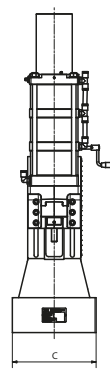

XL-DA Type

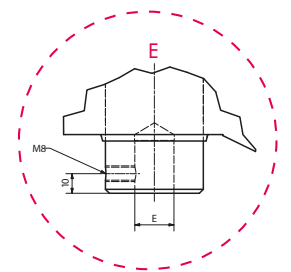
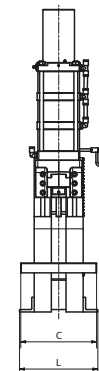

For details of fine stroke adjustment see page 37.

DA Series with round ram and 150 mm throat
 XL-DA Series with round ram and 300 mm throat

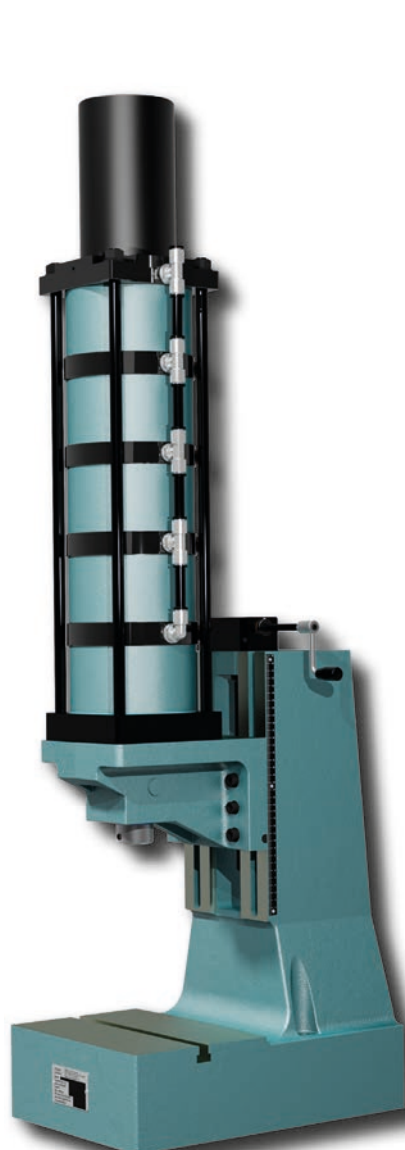

DA 5600-40-150

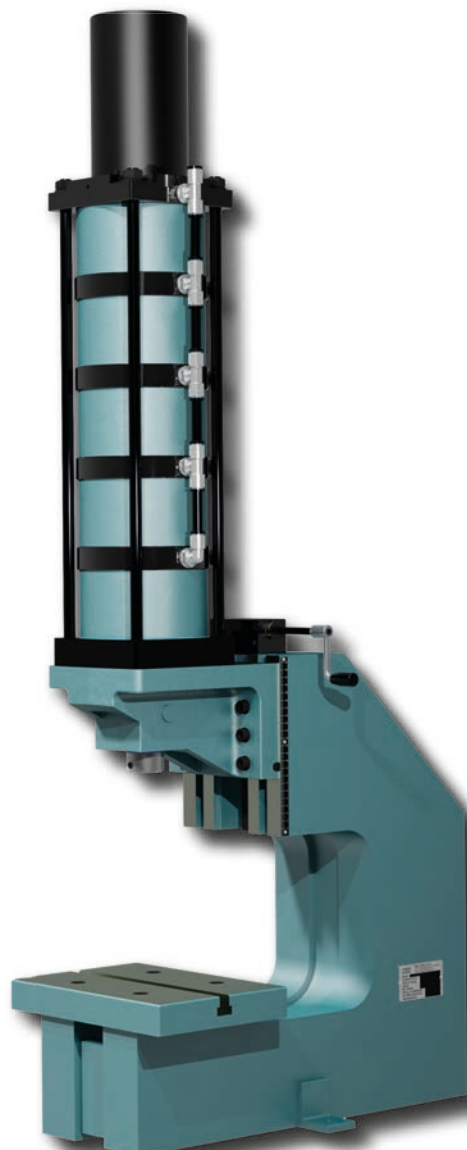

XL-DA 5600-40-300

Direct-acting pneumatic presses

Type			DA 3300-*-150	DA 4500-*-150	DA 5600-*-150	XL-DA 3300-*-300	XL-DA 4500-*-300	XL-DA 5600-*-300
Capacity at 6 bar		kN	33	45	56	33	45	56
Working stroke max. *		mm	40/60/80/100/120	40/60/80/100/120	40/60/80/100/120	40/60/80/100/120	40/60/80/100/120	40/60/80/100/120
Throat	A	mm	150	150	150	150	150	150
Throat C-frame	H	mm				300	300	300
Daylight	B	mm	155 -365	155 -365	155 -365	195 - 290	195 - 290	195 - 290
Daylight C-frame	BB	mm				190	190	190
Table size	CxD	mm	300 x 210	300 x 210	300 x 210	310 x 220	310 x 220	310 x 220
T-slot width similar to DIN 650		mm	14	14	14	16	16	16
Ram bore Ø x Depth	E	mm	20H7 x 25	20H7 x 25	20H7 x 25	20H7 x 25	20H7 x 25	20H7 x 25
Ram Ø	F	mm	50	50	50	50	50	50
Air connection			G 1/2"	G 1/2"	G 1/2"	G 1/2"	G 1/2"	G 1/2"
Air consumption/cm cyl. stroke		l	5.2	6.5	7.9	5.2	6.5	7.9
Space requirement	CxG	mm	300 x 455	300 x 455	300 x 455	320 x 610	320 x 610	320 x 610
Stand height	K	mm	630	630	630	630	630	630
Weight		kg	227	233	239	300	306	312

* Specify the stroke length when ordering.

Valve and service unit only included with controller. Design may vary.

The controller model MPS-2 conforms to the safety requirements which must be applied according to the EC Machinery Directive 2006/42/EC and to the standards for the safety of pneumatic presses. MPS-2 two-hand controls fulfil all requirements of type III C according to DIN EN ISO 13851. mäder presses can therefore be used at workstations with manual loading and open tools. Safety is provided here by the controller, which is designed to be both electrically and pneumatically redundant.

MPS-2 controls include a press safety valve, maintenance unit, push button with protective collar, PLC with free interfaces, Ethernet interface and an integrated web server for remote maintenance, as well as an insert for standard micro SD cards and an electronic piece counter.

A key switch can be used to select between 2-hand operation or external control.

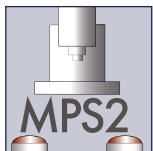

MPS-2
Basic version for two-hand operation.

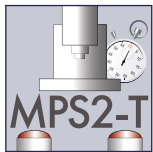

MPS-2 T
MPS-2 controller with additional stop time function. When the press has reached its end position, a timer can be used to determine when the return stroke should take place.

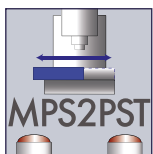

MPS-2 PST
This type of MPS-2 controller is used to control a pneumatic slide table in addition to the press. The scope of supply also includes the stop time function (see MPS-2 T)

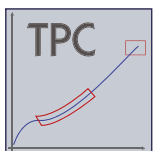

MPS-2 TPC
MPS-2 controller with an additional module TPC-MIDI for force/ displacement monitoring.



Applications:

Joining and assembly processes using presses must today be carried out safely and if possible without retrospective checking. Specified parameters which define the press process must be maintained during production. Only in this way can the quality and safety of the manufactured product be guaranteed. For this reason, TPC-MIDI is used wherever consistent joining processes are required, the progress of which has to be checked and if applicable documented by means of software.

TPC-MIDI monitors the press operation, compares the actual progress with the requirements and subsequently evaluates it. In this way, reject parts can be reliably detected and separated out.

TPC-MIDI can be used both with hand-operated presses and with pneumatic presses. However, the TPC-MIDI is also available as a pure system component if a PLC environment already exists, e.g. in an automation system.

The advantages:

- ▶ TPC-MIDI can be programmed via the membrane keyboard or conveniently using the PC software.
- ▶ TPC-MIDI stores 16 different measuring programs
- ▶ Modern curve evaluation via freely parameterisable windows
- ▶ Evaluation options: Window, trapezoid window, block window, envelop curve, thresholds on the x or y axis.
- ▶ Interfaces: Ethernet and USB. Optional fieldbus integration with PROFIBUS, PROFINET or EtherNet/IP.
- ▶ Force measurement directly in the force characteristic with DMS sensor developed especially for presses.
- ▶ Software for programming and saving monitoring programmes, as well as for documentation of the individual press-fit processes

Clear OK / NOK message

With OK parts, the indicator light is green and the press is ready for the next working stroke.

NOK parts are reliably reported by the TPC-MIDI as an audible signal and by a red indicator light.

The next press stroke cannot be initiated until the error has been acknowledged.



DA 2800-40-130 with MPS-2 TPC

System structure

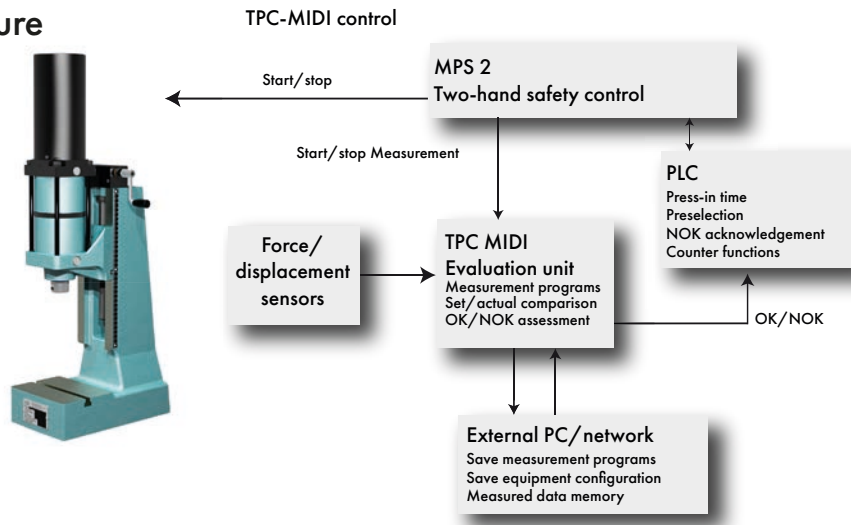

Load cell force sensors for TPC-MIDI

The load cell force sensor is fixed inside the ram bore. The tool holder can be fixed in the hole at the other end of the sensor. The force sensor is therefore always directly in the force flow between the press ram and the tool.

Measurement range	Measured value divergence	Tool holder
0 – 500 N	≤ ± 0.5% of EV	10H7 x 24 mm
0 – 1 kN	≤ ± 0.5% of EV	10H7 x 24 mm
0 – 2 kN	≤ ± 0.5% of EV	10H7 x 24 mm
0 – 5 kN	≤ ± 2.0% of EV	10H7 x 24 mm
0 – 10 kN	≤ ± 2.0% of EV	10H7 x 24 mm
0 – 20 kN	≤ ± 1.0% of EV	10H7 x 24 mm
0 – 50 kN	≤ ± 1.0% of EV	20H7 x 24 mm
0 – 100 kN	≤ ± 1.0% of EV	20H7 x 24 mm

Unless expressly required to the contrary, the load cell force sensor is selected to match the maximum capacity of the press used



Potentiometric travel meter

Travel is measured potentiometrically. The service life of the sensors is 10⁸ movements

Press stroke	Resolution	Linearity error
40 mm	0.025 mm	0.42%
60/80 mm	0.038 mm	0.41%
100 mm	0.050 mm	0.40%
120 mm	0.075 mm	0.40%

Monitoring windows

Pass-through window

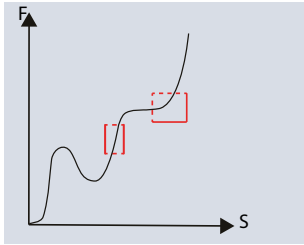

The force/displacement curve must pass through the window from the entry to the exit side as defined without one of the other window boundaries being infringed. The entry and exit sides can be freely selected.

Block window

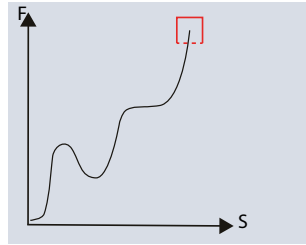

The block window monitors the final values of the press operation. With this type of window, the force/displacement curve must enter the specified entry side and must not leave the window again.

Envelope curve

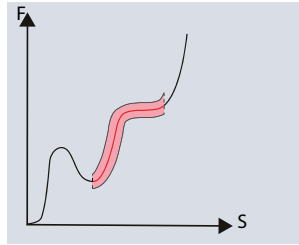

The measuring curve must pass continuously through the envelope curve and must not infringe it. The envelope curve is taught by means of a teach-in process. Its X-axis parameters and the delta-Y, i.e. the force tolerance range, are then defined.

Monitoring window

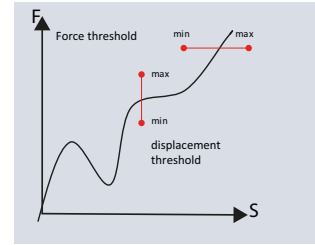

Thresholds define minimum values that must be reached within a certain range and may no longer be undershot. A force threshold (Y-axis) and alternatively a displacement threshold (X-axis) are available.

The reference points of the monitoring windows

The reference points of the monitoring windows on the X-axis can be defined both rigidly and dynamically.

Absolute

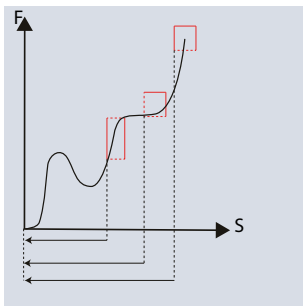

In the case of assembled parts with high repeat accuracy, the calibrated zero point of the displacement sensor on the X-axis is used as the reference point.

Trigger

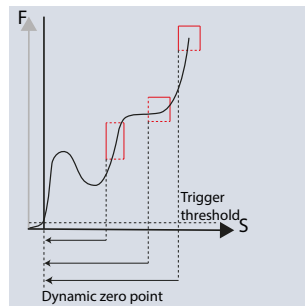

If the assembly sequence is identical as such, but the start of assembly has a major deviation on the X-axis, the beginning of the measurement can be defined by setting a trigger threshold on the Y-axis.

End force

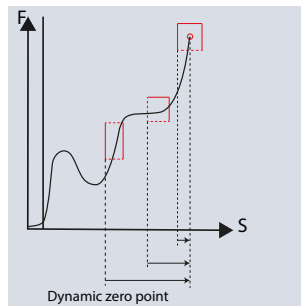

If a measurement with an absolute or a trigger reference point is not useful, the position of the end force (Fmax) on the x-axis can be selected as the reference point. The position of the evaluation window on the X-axis then relates in reverse to this dynamic zero point.

Block window

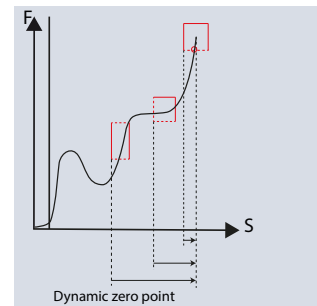

If the end force shows a wide spread, the reference point of the evaluation windows can also be defined using the entry of the curve into the block window. Any values after the block window has been reached are no longer taken into account. The position of the evaluation windows on the X-axis then relates in reverse to this dynamic zero point.

PC Software

TPC-MIDI is supplied as standard with the basic version of the software, with which the configuration of TPC-Midi and measurement programs can be set up and saved.

Equipment configuration

- ▶ Settings or teach-in of the force and displacement sensors (X/Y axes)
- ▶ Stipulation of measurement method and reference points
- ▶ Backup of complete unit configurations (up/download)

Measurement programs

- ▶ Creation and internal saving of 16 measuring programs. Further measurement programs can be created, saved and reloaded when required.
- ▶ Input of sets of curves
- ▶ Creation of monitoring windows and envelope curve
- ▶ Test runs with OK or NOK assessment

With the licensed full version, the production data per press-in operation can be recorded in addition.

- ▶ Production mode
- ▶ Measured data recording
- ▶ Clear-cut part reference
- ▶ Besides the programme's own format automatic print and export to ACII and Excel

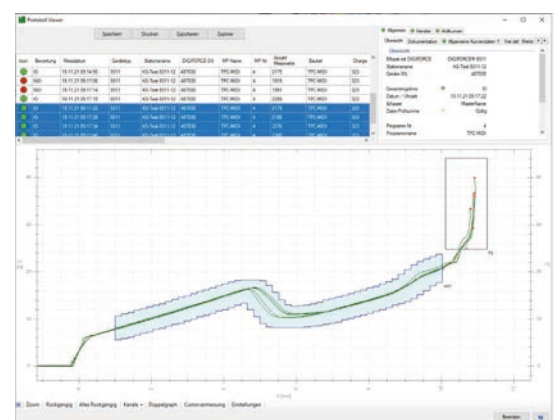
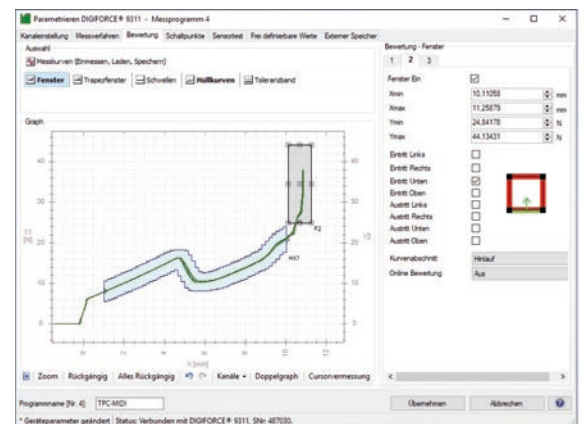
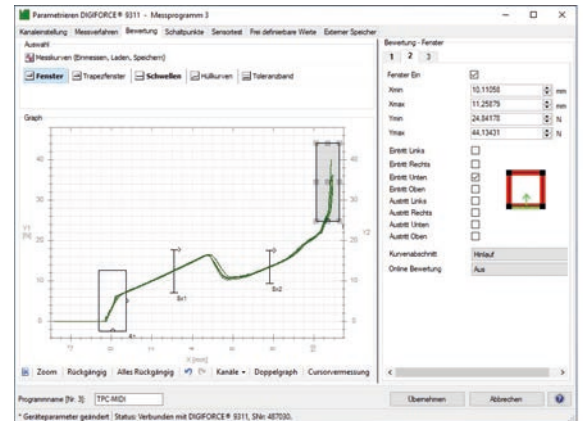

grihtoinom 22e0017 ibiM-09TTPC-Midi Process monitoring