

## The accessories

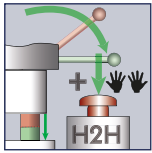
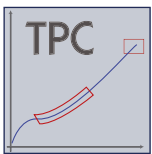
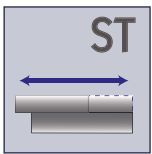
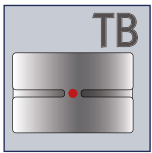
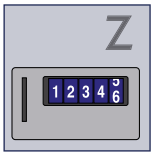
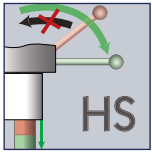
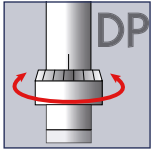

Für  
EP 500-40  
EP 750-40  
VK 500-40  
VK 750-40

## Manual toggle presses with round ram EP range

EP Type toggle presses in 5 kN, 7.5 kN and 12 kN sizes are designed for serial or individual manufacture in manual workstations. As the nominal end force is produced at the end of the stroke, a large force can be exerted at the exact point it is required. The manual force of 120 N to be applied is user-friendly. As many applications require less force, fatigue-free working is possible even with serial production.

## ERGOPRESS® hand lever

- ▶ Ergonomic user comfort.
- ▶ 360° stepless adjustment
- ▶ Lever angled to the side: free view of work area and ergonomically comfortable position.
- ▶ Simple and easy conversion for left-handers (except HS and Z option) without losing the tool setting. Ideal for job sharing on one press.

EP-type presses are modern production tools with high precision. The user-friendly design increases productivity and prevents forced and abnormal postures of the operator due to the workplace.



Manual lever can be refitted for right and left-handers

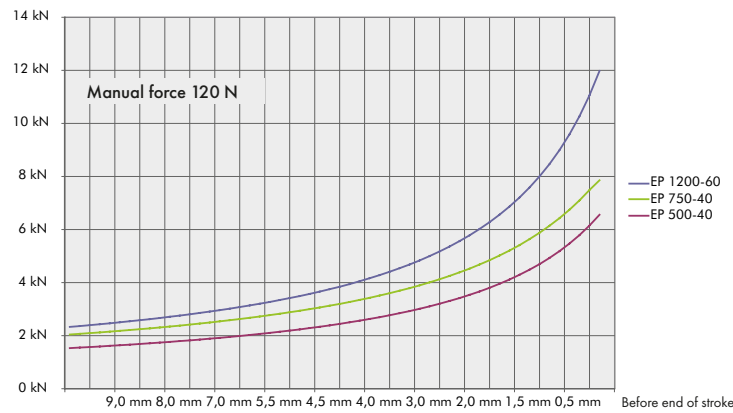

## Standard

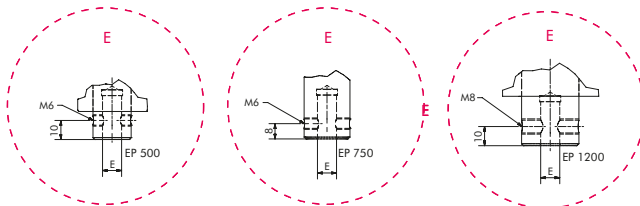

## With DP

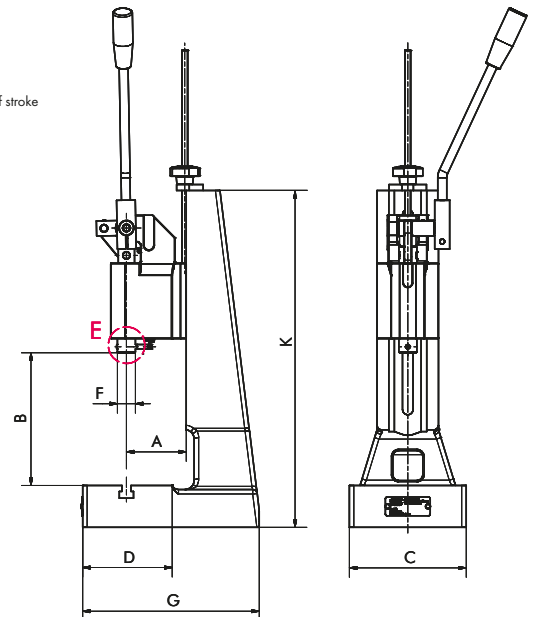
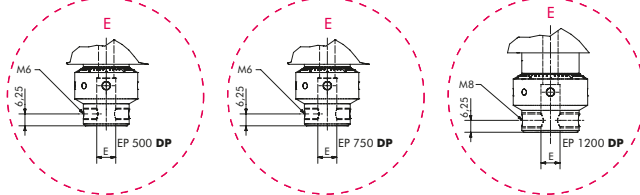

EP range  
L-EP range with extra large daylight

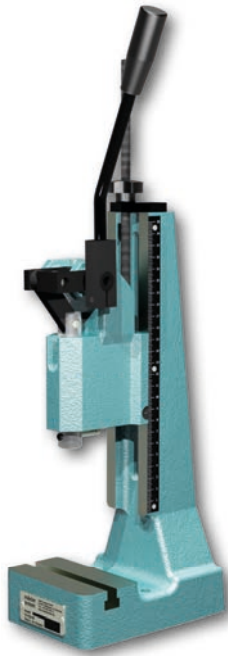

EP 500-40

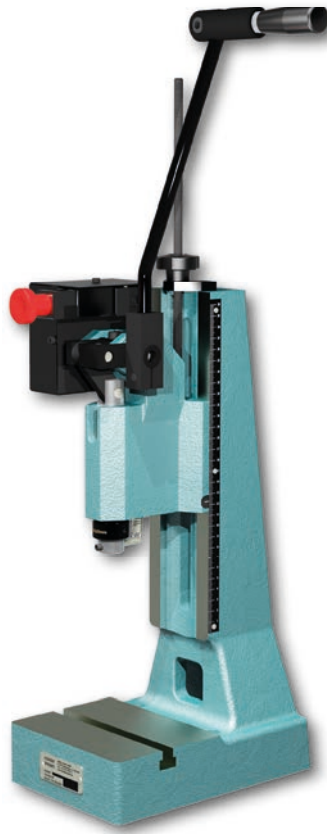

EP 750-40

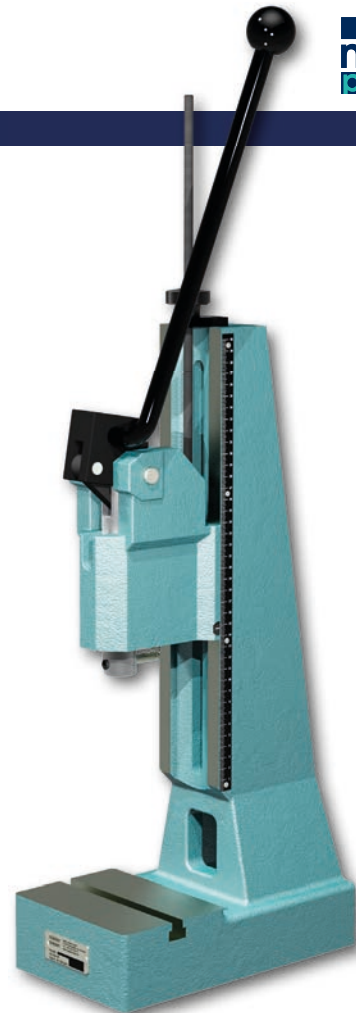

L-EP 1200-60

with accessories  
DP - Precision ram adjustment  
HS - Return travel lock  
equipped with ERGO hand lever\*

toggle presses

Type			EP 500-40	EP 750-40	L-EP 750-40	EP 1200-60	L-EP 1200-60
Capacity		kN	5.0	7.5	7.5	12.0	12.0
Working stroke		mm	40	40	40	60	60
Throat	A	mm	63	80	80	80	80
Daylight	B	mm	40 - 213	58 - 265	55 - 375	62 - 240	75 - 338
Daylight with DP	B	mm	20 - 197	38 - 250	39 - 359	48 - 231	53 - 328
Table size	CxD	mm	110 x 65	157 x 115	156 x 115	157 x 115	157 x 115
T-slot width similar to DIN 650		mm	10	12	12	12	12
Ram bore Ø x Depth	E	mm	10H7 x 25	10H7 x 25	10H7 x 25	10H7 x 30	10H7 x 30
Ram bore Ø x Depth with DP	E	mm	10H7 x 25	10H7 x 25	10H7 x 25	10H7 x 25	10H7 x 25
Ram Ø	F	mm	20	24	24	30	30
Space requirement	CxG	mm	110 x 164	157 x 237	156 x 275	157 x 237	156 x 275
Stand height	K	mm	355	450	570	450	570
Weight		kg	ca. 10	ca. 20	ca. 28	ca. 24	ca. 32

Accessories (see Page 8-9)	Please specify when ordering.				
Precision ram adjustment	DP	DP	DP	DP	DP
Return travel lock	HS	HS	HS	HS	HS
Counter	Z	Z	Z	Z	Z
Table bore 12H7	TB	TB	TB	TB	TB

\*Not included. Accessories must be ordered separately.

## The accessories

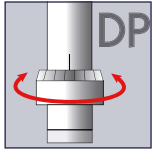

## APK T range

The extra-powerful hand-operated toggle presses of the APK T 3 and APK T 4 ranges are especially suitable for the frequently changing applications in modelmaking and in the workshop. Their high forces of up to 30 kN enable them to be flexibly used for widely differing applications.

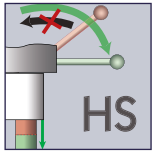

## The advantages:

- ▶ Choice of different stroke lengths
- ▶ Extra-stable press base design
- ▶ Daylight easily adjustable by means of the standard press head threaded spindle height adjustment
- ▶ The nominal force of the press can be achieved with moderate applied force

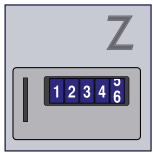

## XL-APK T range with 250 mm throat

A larger throat is required wherever bulky parts are processed, e.g. the processing of printed circuit boards, sheet metal and similar parts. **mäder** XL presses with 250 mm throat are employed in such cases. The base is a stable welded structure to which different standard press heads can be fitted.

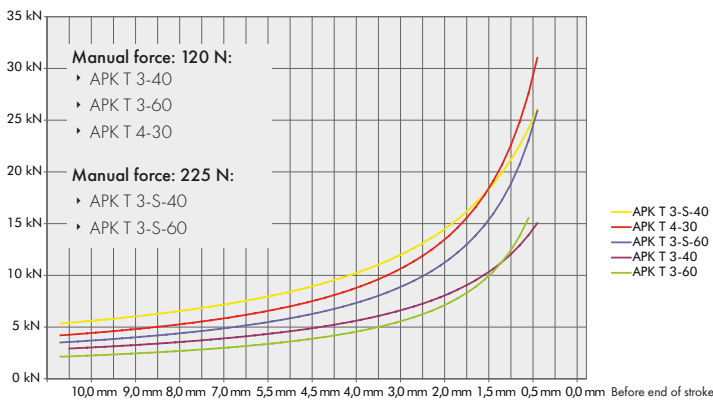
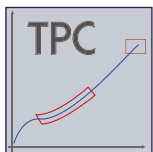
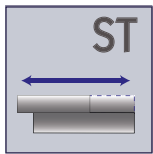
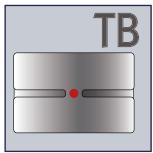

Standard

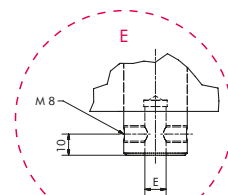

With DP

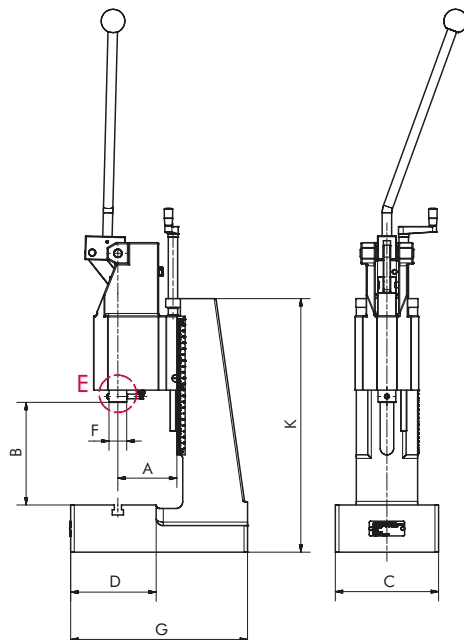
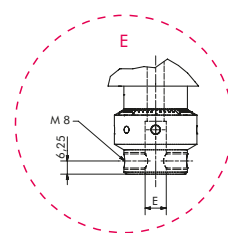

XL models

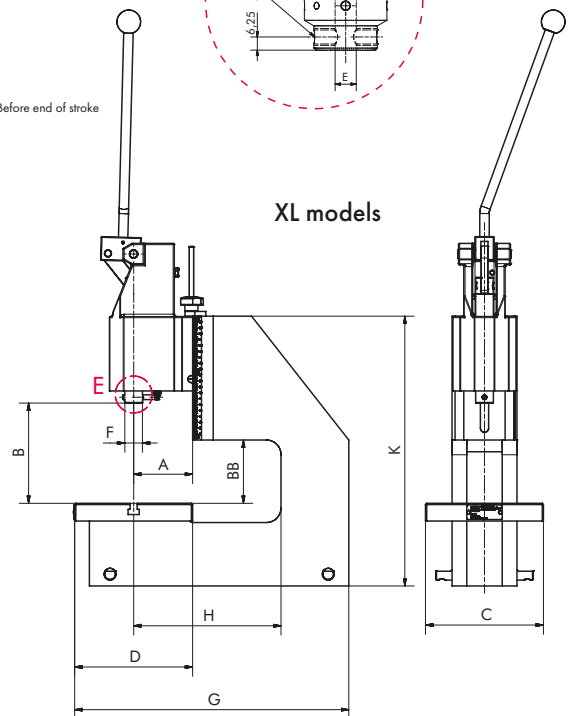

APK T range  
XL-APK T range with 250 mm throat



toggle presses

**APK T 3-40**  
equipped with ERGO hand lever\*

**APK T 3-S-60**

**XL-APK T 3-40**

Type			APK T3-40	APK T3-60	APK T3-S-40	APK T3-S-60	APK T4-30	XL-APK T3-40	XL-APK T3-60
Capacity		kN	15.0	15.0	25.0	25.0	30.0	15.0	15.0
Working stroke		mm	40	60	40	60	30	40	60
Throat	A	mm	100	100	100	100	100	100	100
Throat C-frame	H	mm	-	-	-	-	-	250	250
Daylight	B	mm	49 - 168	51 - 172	60 - 290	65 - 295	55 - 285	88 - 166	90 - 168
Daylight with DP	B	mm	35 - 154	30 - 151	46 - 274	44 - 274	34 - 264	72 - 150	69 - 147
Daylight C-frame	BB	mm	-	-	-	-	-	100	100
Table size	CxD	mm	175 x 140	175 x 140	185 x 145	185 x 145	185 x 145	200 x 200	200 x 200
T-slot width similar to DIN 650		mm	12	12	12	12	12	12	12
Ram bore Ø x Depth	E	mm	10H7 x 30	10H7 x 30	10H7 x 30	10H7 x 30	10H7 x 30	10H7 x 30	10H7 x 30
Ram bore Ø x Depth with DP			10H7 x 25	10H7 x 25	10H7 x 25	10H7 x 25	10H7 x 25	10H7 x 25	10H7 x 25
Ram Ø	F	mm	30	30	30	30	30	30	30
Space requirement	CxG	mm	175 x 300	175 x 300	185 x 320	185 x 320	185 x 320	200 x 465	200 x 465
Stand height	K	mm	425	425	520	520	520	465	465
Weight		kg	ca. 39	ca. 43	ca. 58	ca. 63	ca. 63	ca. 54	ca. 58

Accessories (see Page 8-9)	Please specify when ordering.							
Precision ram adjustment	DP	DP	DP	DP	DP	DP	DP	DP
Return travel lock	HS	HS	HS	HS	HS	HS	HS	HS
Counter	Z	Z	Z	Z	Z	Z	Z	Z
Table bore 12H7	TB	TB	TB	TB	TB	TB	TB	TB

\*Not included. Accessories must be ordered separately.

## The accessories

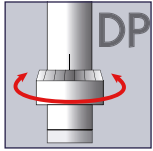

### VK range

The square ram has significant advantages compared with the round ram:

- ▶ Absolute protection against twisting
- ▶ Hardened and precisely ground ram
- ▶ Press ram guide free from play
- ▶ Readjustable jib strips for square ram
- ▶ Large tool locating surface
- ▶ Guides in tool therefore usually unnecessary
- ▶ Practically maintenance-free operation

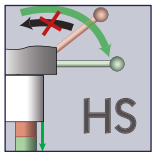

maeder hand-operated toggle presses with square ram are ideal tools for manufacturing small precision parts with tight tolerances in small and medium-sized batches where automation would be too cost-intensive.

### ERGOPRESS® hand lever

- ▶ Ergonomic user comfort.
- ▶ 360° stepless adjustment
- ▶ Lever angled to the side: free view of work area and ergonomically comfortable position.
- ▶ Simple and easy conversion for left-handers (except HS and Z option) without losing the tool setting. Ideal for job sharing on one press.

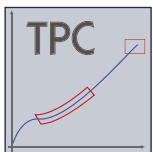
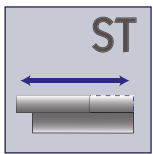
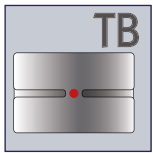
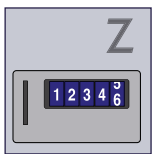

Manual lever can be refitted for right and left-handers

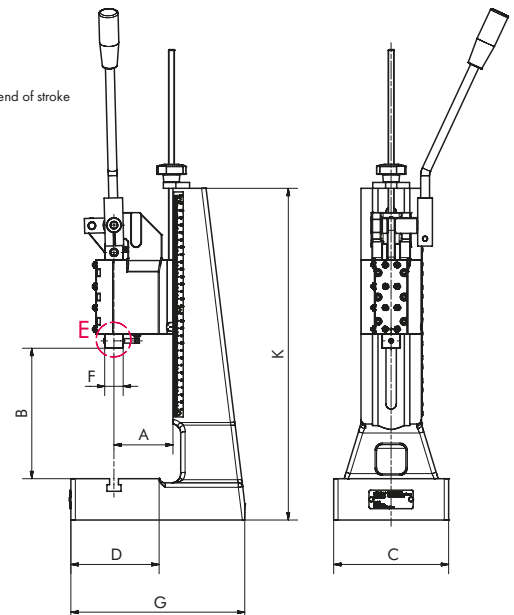
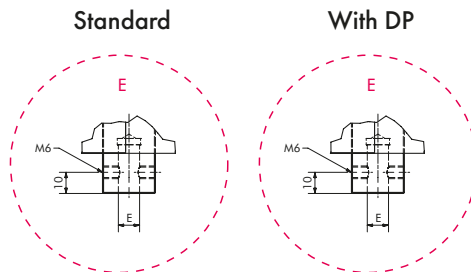
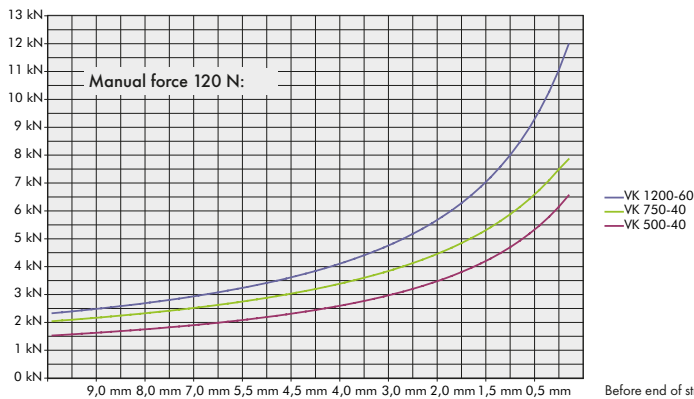

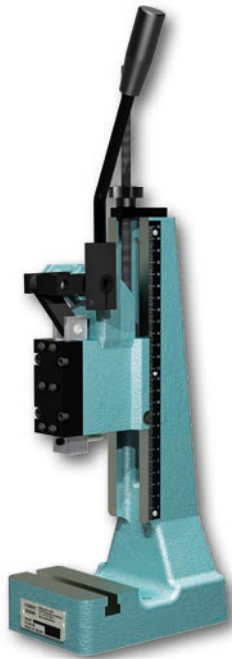

VK 500-40

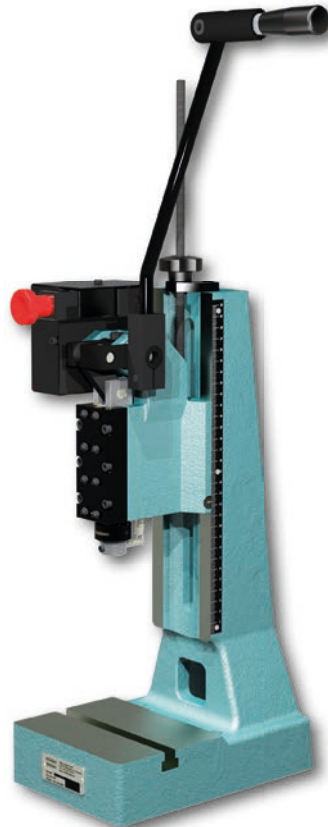

VK 750-40

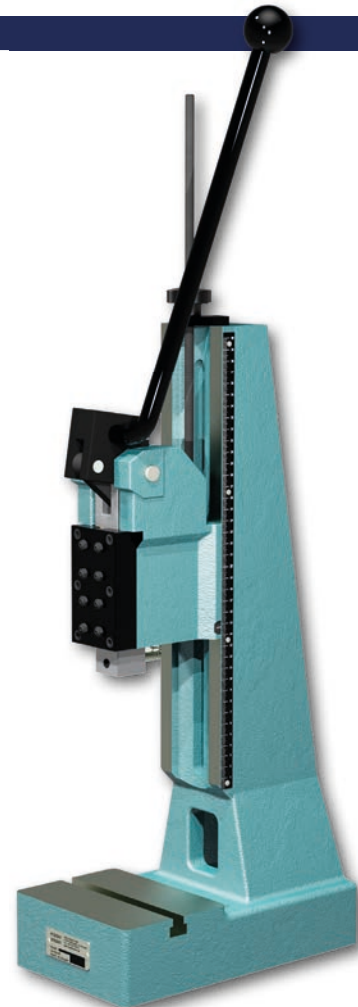

L-VK 1200

with accessories  
DP - Precision ram adjustment  
HS - Return travel lock  
equipped with ERGO hand lever\*

Toggle presses

Type			VK 500-40	VK 750-40	L-VK 750-40	VK 1200-60	L-VK 1200-60
Capacity		kN	5.0	7.5	7.5	12.0	12.0
Working stroke		mm	40	40	40	60	60
Throat	A	mm	63	80	80	80	80
Daylight	B	mm	40 - 213	53 - 265	55 - 375	45 - 245	52 - 338
Daylight with DP	B	mm	25 - 197	38 - 250	39 - 359	31 - 231	38 - 328
Table size	CxD	mm	110 x 65	157 x 115	157 x 115	157 x 115	157 x 115
T-slot width similar to DIN 650		mm	10	12	12	12	12
Ram bore Ø x Depth	E	mm	10H7 x 25	10H7 x 25	10H7 x 25	10H7 x 30	10H7 x 30
Ram bore Ø x Depth with DP	E	mm	10H7 x 25	10H7 x 25	10H7 x 25	10H7 x 25	10H7 x 25
Ram area	F	mm	21 x 21	25 x 25	25 x 25	31 x 31	31 x 31
Space requirement	CxG	mm	110 x 164	155 x 237	156 x 275	155 x 237	156 x 275
Stand height		mm	355	450	570	450	570
Weight		kg	ca. 10	ca. 20	ca. 28	ca. 24	ca. 32

Accessories (see Page 8-9)	Please specify when ordering.				
Precision ram adjustment	DP	DP	DP	DP	DP
Return travel lock	HS	HS	HS	HS	HS
Counter	Z	Z	Z	Z	Z
Table bore 12 <sup>H7</sup>	TB	TB	TB	TB	TB

\*Not included. Accessories must be ordered separately.

## The accessories

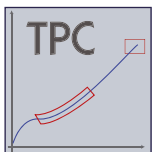
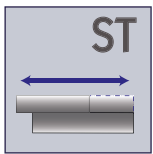
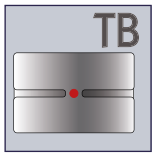
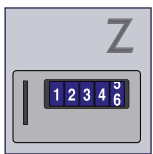
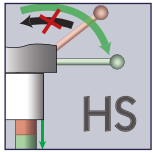
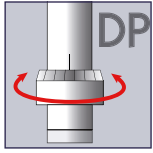

## VK range

The extra-powerful hand-operated toggle presses of the VK range are especially suitable for the frequently changing applications in modelmaking and in the workshop. Their high forces of up to 30 kN enable them to be flexibly used for widely differing applications.

## The advantages:

- ▶ Choice of different stroke lengths
- ▶ Extra-stable press base design
- ▶ Daylight easily adjustable by means of the standard press head threaded spindle height adjustment
- ▶ The nominal force of the press can be achieved with moderate applied force

## XL-VK range with 250 mm throat

A larger throat is required wherever bulky parts are processed, e.g. the processing of printed circuit boards, sheet metal and similar parts. mäder XL presses with 250 mm throat are employed in such cases. The base is a stable welded structure to which different standard press heads can be fitted.

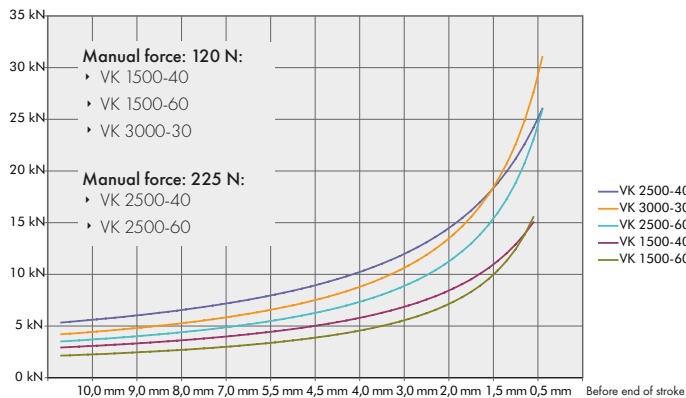

## XL models

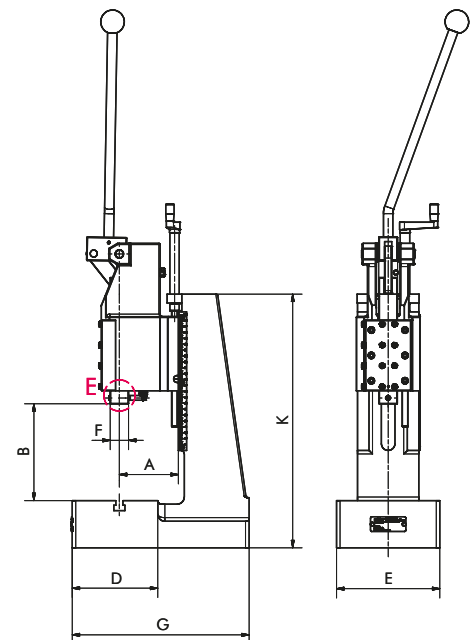
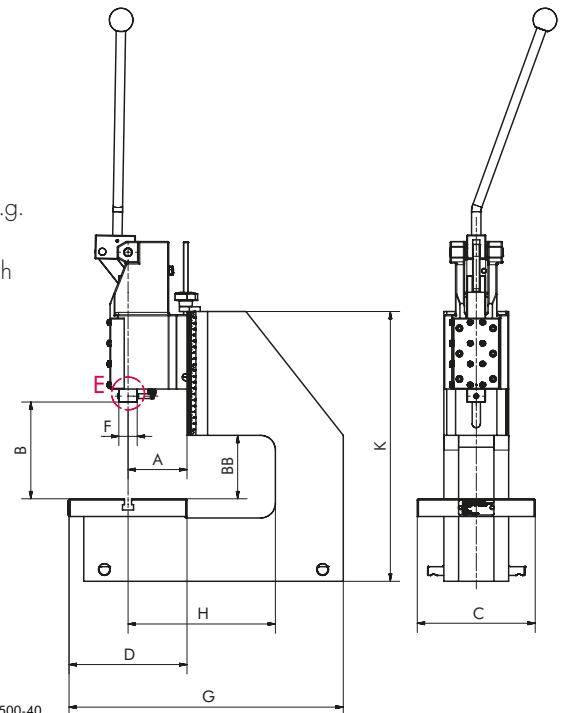

## Standard

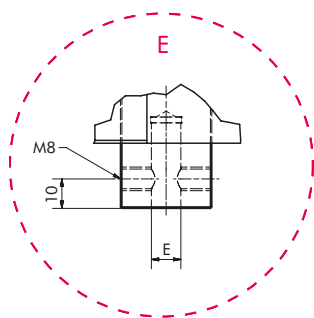

## With DP

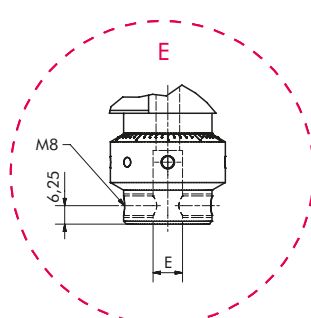

VK range  
XL-VK range with 250 mm throat



Toggle presses

VK 1500-40  
equipped with ERGO hand lever\*

VK 2500-60

XL-VK 1500-40

Type			VK 1500-40	VK 1500-60	VK 2500-40	VK 2500-60	VK 3000-30	XL-VK 1500-40	XL-VK 1500-60
Capacity		kN	15.0	15.0	25.0	25.0	30.0	15.0	15.0
Working stroke		mm	40	60	40	60	30	40	60
Throat	A	mm	100	100	100	100	100	100	100
Throat C-frame	H	mm	-	-	-	-	-	250	250
Daylight	B	mm	49 - 168	49 - 168	60 - 290	65 - 295	65 - 295	80 - 166	88 - 166
Daylight with DP	B	mm	35 - 154	35 - 154	46 - 274	44 - 274	44 - 274	72 - 150	72 - 150
Daylight C-frame	BB	mm	-	-	-	-	-	100	100
Table size	CxD	mm	175 x 140	175 x 140	185 x 145	185 x 145	185 x 145	200 x 200	200 x 200
T-slot width similar to DIN 650		mm	12	12	12	12	12	12	12
Ram bore Ø x Depth	E	mm	10H7 x 30	10H7 x 30	10H7 x 30	10H7 x 30	10H7 x 30	10H7 x 30	10H7 x 30
Ram bore Ø x Depth with DP	E	mm	10H7 x 25	10H7 x 25	10H7 x 25	10H7 x 25	10H7 x 25	10H7 x 25	10H7 x 25
Ram area	F	mm	31 x 31	31 x 31	31 x 31	31 x 31	31 x 31	31 x 31	31 x 31
Space requirement	CxG	mm	175 x 300	175 x 300	185 x 320	185 x 320	185 x 320	200 x 465	200 x 465
Stand height	K	mm	425	425	520	520	520	465	465
Weight		kg	ca. 39	ca. 43	ca. 58	ca. 63	ca. 63	ca. 55	ca. 59

Accessories (see Page 8-9)	Please specify when ordering.							
Precision ram adjustment	DP	DP	DP	DP	DP	DP	DP	DP
Return travel lock	HS	HS	HS	HS	HS	HS	HS	HS
Counter	Z	Z	Z	Z	Z	Z	Z	Z
Table bore 12H7	TB	TB	TB	TB	TB	TB	TB	TB

\*Not included. Accessories must be ordered separately.



## The accessories

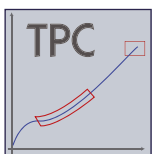
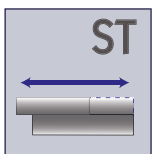
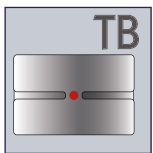
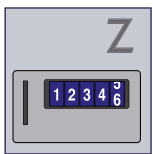
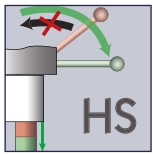

## APZ range

mäder rack and pinion presses transmit their force constantly over the whole stroke length. The direct transmission of force via the manual lever allows fine control. Rack and pinion presses are therefore used where a constant force characteristic over a longer stroke is required.

## Manual lever with ergonomic user comfort

- ▶ Can be turned through 360°: adaptable for any body size and application.
- ▶ Lever angled to the side: free view of work area and ergonomically comfortable position.
- ▶ **R/L Version:** simple and easy conversion for left-handers without losing the tool setting. Ideal for job sharing on one press.



Manual lever can be refitted for right and left-handers

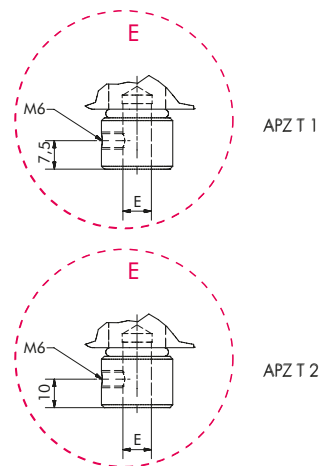
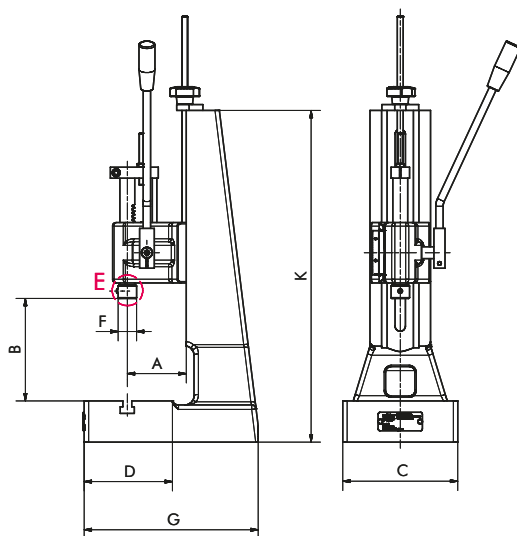
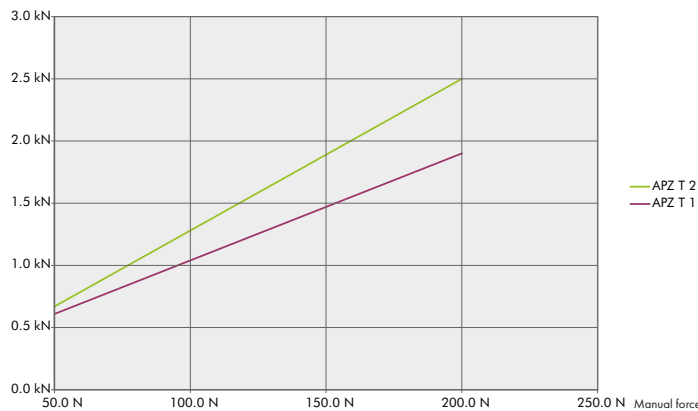

APZ range  
L-APZ range with extra large daylight



APZ T 1-40

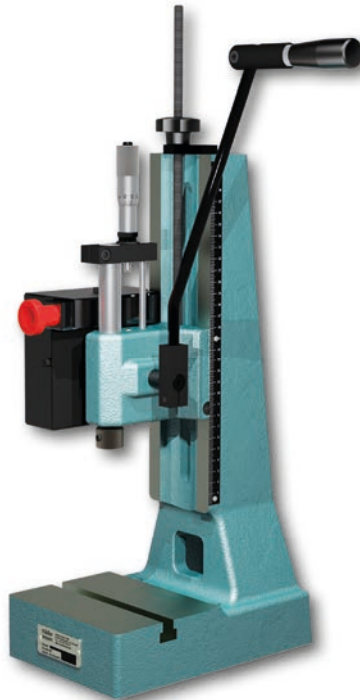

APZ T 2-50

with accessories  
HS – Return travel lock  
MICRO – Micrometer stop  
Equipped with ERGO hand lever\*\*

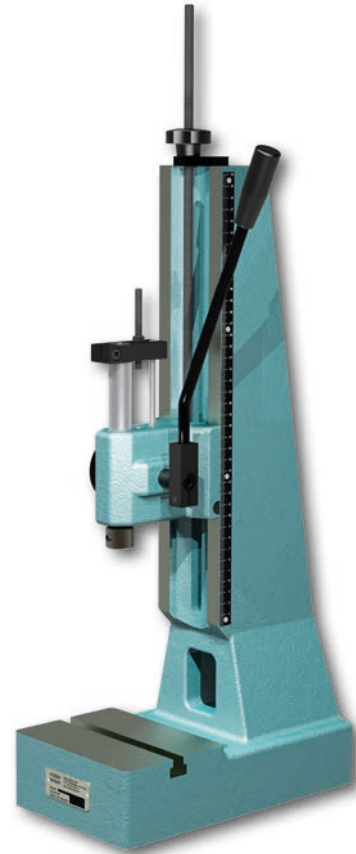

L-APZ T 2-50

Rack and pinion presses

Type			APZ T1-40	APZ T1-90	APZ T2-50	APZ T2-100	L-APZ T2-50	L-APZ T2-100
Capacity		kN	1.5	1.5	2.5	2.5	2.5	2.5
Working stroke		mm	40	90	50	100	50	100
Throat	A	mm	63	63	80	80	80	80
Daylight	B	mm	40 - 235	40 - 235	42 - 290	42 - 290	55 - 390	55 - 390
Table size	CxD	mm	110 x 65	110 x 65	157 x 115	157 x 115	157 x 115	157 x 115
T-slot width similar to DIN 650		mm	10	10	12	12	12	12
Ram bore Ø x Depth	E	mm	10H7 x 25	10H7 x 25	10H7 x 25	10H7 x 25	10H7 x 25	10H7 x 25
Ram Ø	F	mm	25	25	25	25	25	25
Space requirement	CxG	mm	110 x 164	110 x 164	157 x 237	157 x 237	156 x 275	156 x 275
Stand height	K	mm	355	355	450	450	570	570
Weight		kg	ca. 8.5	ca. 8.5	ca. 21	ca. 21	ca. 29	ca. 29

Accessories (see Page 8-9)	Please specify when ordering.						
Return travel lock	HS	HS	HS	HS	HS	HS	HS
Micrometer stop	MICRO	MICRO	MICRO	MICRO	MICRO	MICRO	MICRO
Counter	Z	Z	Z	Z	Z	Z	Z
Table bore 12 <sup>H7</sup>	TB	TB	TB	TB	TB	TB	TB
Left/right-hander version*	R/L	R/L	R/L	R/L	R/L	R/L	R/L

\* Can only be combined with the MICRO and TB accessories.

\*\*Not included. Accessories must be ordered separately.

Low-cost monitoring and logging of pressing processes with mäder hand presses.

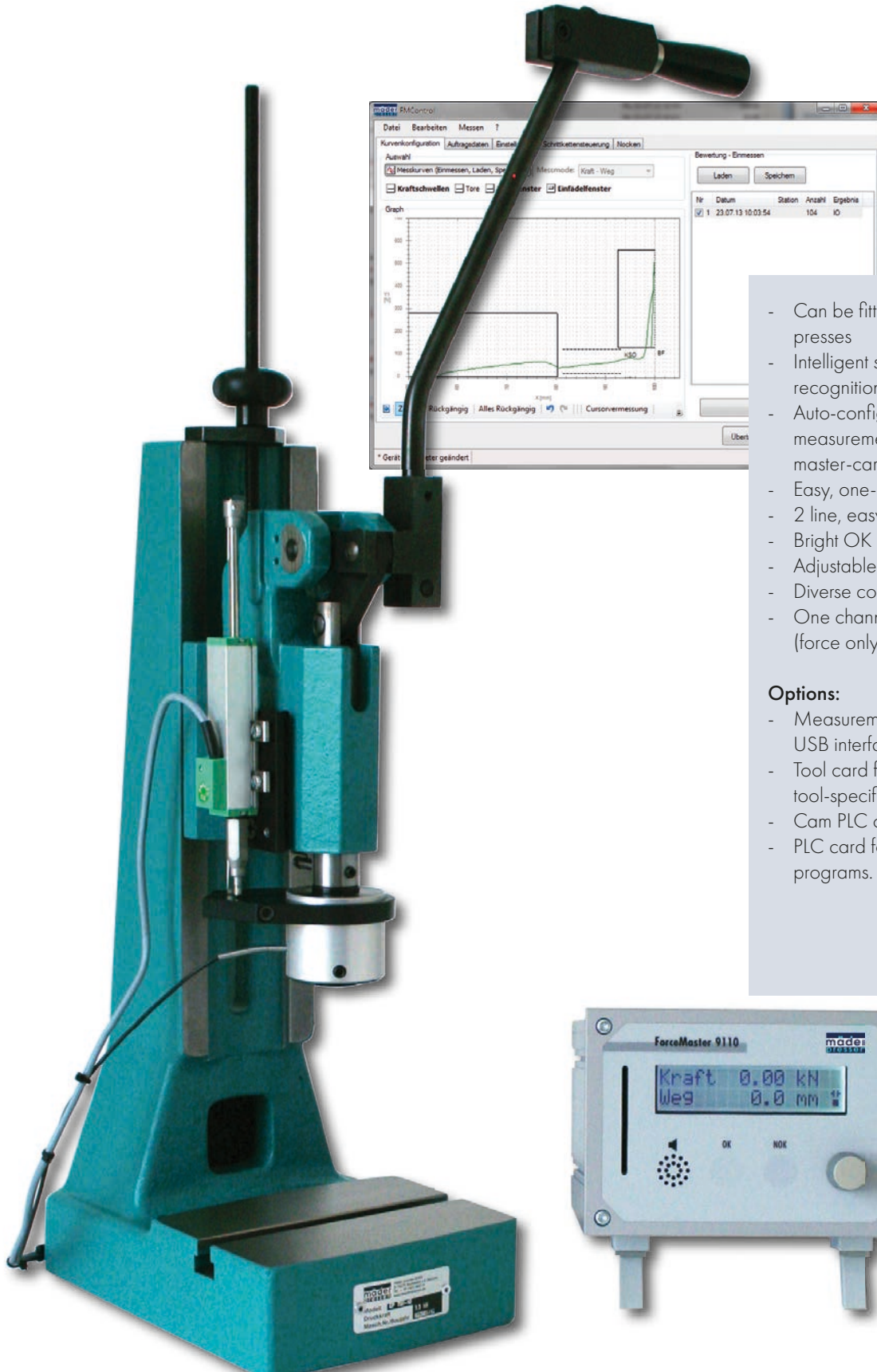

- Can be fitted to all mäder hand presses
- Intelligent sensors, automatic recognition of sensor values
- Auto-configuration of the measurement program with the master-card
- Easy, one-button operation
- 2 line, easy read display
- Bright OK /NOK displays
- Adjustable alarm tone
- Diverse counter functions
- One channel measurement (force only) possible

**Options:**

- Measurement logging via USB interface
- Tool card for storing and setting tool-specific measurement data
- Cam PLC operation
- PLC card for storing and setting programs.



The TPC ForceMaster can be set up quickly and easily:

### Sensor detection

The connectors of the force and displacement sensors are not interchangeable, and are therefore protected from false connections. The characteristics of the sensor are already stored on a printed circuit board in the connector plug. When the TPC ForceMaster is switched on, the sensors are automatically detected and the zero point determined. If the sensors are exchanged, the sensor change will be shown in the display and must be confirmed.

### Auto-configuration

The TPC ForceMaster creates a process monitoring proposal, based on a one-time teach-in process of a good part. This proposal can either be accepted or modified manually on the device or with the help of the supplied software. A good part consists of parts which were checked before the pressing process as to whether they are within the manufacturing tolerances and from which it can therefore be expected that the process will in turn manufacture a good part.

### Evaluation variants

#### Threading

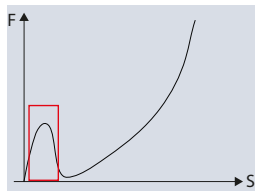

The threading area performs a check to determine whether the maximum force will be exceeded at the start of a joining process. An alarm will notify a warning that parts or the tool could possibly be damaged. The threading area must be activated.

#### Gates

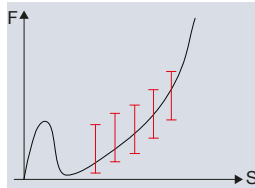

With the auto-configuration, 5 gates will be activated. A gate is defined by a path position and a minimum and maximum force. The forced-displacement curve for good parts must run through all the gates, and no gate may be circumvented. The evaluation is performed when the press stroke has exceeded the path position of all the gates.

#### Force thresholds

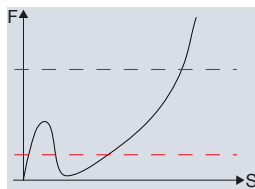

Force thresholds define a minimum force to be achieved and a maximum force threshold, within which the entire force fitting process must be performed once the minimum force has been reached.

#### Block area End position

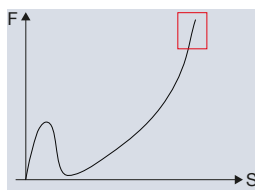

Often the force fitting process is concluded with a high force exertion at the end of the stroke: the block area. It is defined by a force and displacement range which may not be under-run or exceeded. The block area is always inactive after the auto-configuration and must be activated as required.

#### Press-fit stem path

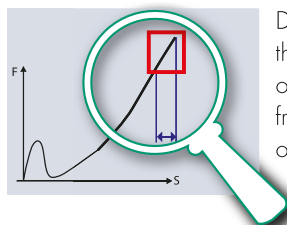

During the deformation processes which occur at the end of the stroke, the press-fit stem path can also be monitored. The press-fit stem path monitoring can only be activated with an active block area. The press-fit stem path is calculated from the path differential between the reaching of the block area and the beginning of the return stroke.

#### Force alarm

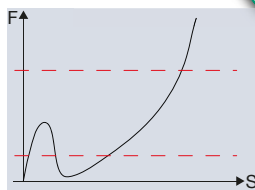

Force alarms are used to monitor the force sensor and will not lead to an NOK rating. There is a top and bottom force alarm available. Force alarms can, for example, be used to perform switching functions.

## OK/NOK notifications

The ForceMaster confirms the manufacturing of an OK part with a green indicator light. A NOK part is notified with a pre-settable signal tone and a red indicator light. By default, the TPC ForceMaster is pre-set in such a manner that the NOK message can only be acknowledged with a master-card. In the manual configuration of the measurement program, this feature can be disabled.

## ForceMaster structural layout

From left to right:

- ▶ Card slot
- ▶ Speaker
- ▶ OK / NOK indicator lights
- ▶ Rotary pushbutton for programming



## Counter

Six different counter types can be set via the configuration menu:

- ▶ OK parts
- ▶ NOK parts
- ▶ Total of all parts
- ▶ Count down counter
- ▶ R-set (set value for countdown counter)
- ▶ Total stroke counter

## Software

The software for the visualisation and correction of the auto-configuration is included in the scope of delivery.

## Options:

### USB interface for a USB stick

The graphical curve data can be stored on a USB stick for documentation and evaluation purposes. The cycle time should be  $\geq 3$  seconds.

### Cam PLC

The cam PLC functions in the same manner as an electronic, path-controlled step chain controller. When a cam is reached, the movement direction of the press ram is also evaluated. This enables the programming of an action in the cam area, which is dependent on the work or return stroke. This is based on a step chain control, which sequentially performs an array of processes. Only when a condition is fulfilled will an action be executed and a jump to the next step be performed.

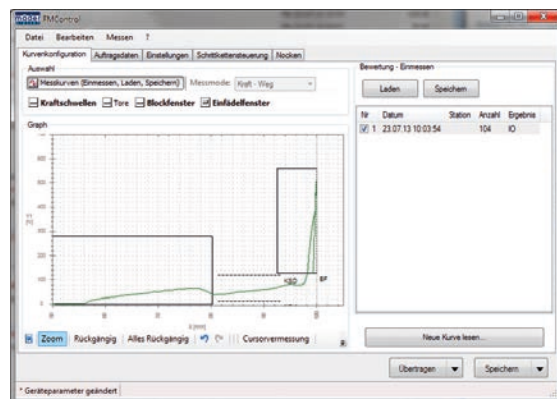

There are 8 inputs and 8 outputs available for programming. The cam PLC can not be used for press-safety purposes.

## SmartCards

- Tool card
- PLC card

## Single-dimensional operation

It is also possible to operate the TPC ForceMaster with the force sensor only.

## TPC ForceMaster Technical Data

General device data	
Display:	2-line backlit LCD display
Warning and acknowledgement sounds:	type of signal can be set
Warning sound volume:	up to 100 dB
Measuring channels:	force/displacement or force/time
Communication interfaces:	USB - Type B slave port, on the rear side RS232 - D-SUB 9, data rate 19.2 kbps
Interface:	USB, RS232
Measurement error:	0.5% from calibration
Electrical connection:	90 ... 240 V AC / 50 ... 60 Hz
Cut-off frequency:	1 kHz
Working temperature range:	0 ... 60 °C
Humidity:	10 ... 80%, non-condensing
Housing:	aluminium profile housing
Protection class:	IP20
Connections:	coded special connectors
Sampling rate:	10 kHz
Number of I/O:	8 inputs / 8 outputs
Dimensions (W x H x D):	150 x 95 x 260 [mm]
Weight: approx.	3 kg

## TPC ForceMaster sensors

### Load cell for TPC ForceMaster

- The ideal, user-friendly force sensors for hand lever presses.  
Cross-thread for the tool attachment.
- By means of the clamping spigot, the sensor can be inserted into the ram bore of the press can be attached.
- The tool is mounted in the mounting hole of the sensor. and fastened with an Allen screw in the transverse thread.

Overall measurement error:	<± 1% from calibration
Maximum usage force:	approx. 120% of the rated power
Protection class:	according to EN 60529: IP54
Diameter:	50 mm
Height without clamping pin:	50 mm
Clamping pin diameter:	10 <sup>H7</sup> x 21 mm
Sensor bore (diameter x depth):	10 <sup>H7</sup> x 25 mm
The sensor must not be subjected to lateral forces.	

### Potentiometer

Linearity deviation:	from 0.1% from calibration
Resolution:	0.01 mm
Protection class according to EN 60529:	IP 40

### Retrofit kit for potentiometer

Existing hand lever presses can be retrofitted with a potentiometer with the retrofit kit. An illustration with the drilling pattern is included.



Measurement ranges	Max. overload
0 - 100 N	1 kN
0 - 250 N	2.5 kN
0 - 0.5 kN	5 kN
0 - 1.0 kN	10 kN
0 - 2.5 kN	25 kN
0 - 5.0 kN	30 kN
0 - 10.0 kN	30 kN
0 - 25.0 kN	30 kN



# Knie hefboom persen

COLOUR LINE®

**5 jaar** garantie\*  
Typische Mader lange termijn garantie

CL 500 K



**CL 500 K**  
5,0 kN

CL 750 K



**CL 750 K**  
7,5 kN

CL 1200 K



**CL 1200 K**  
12,0 kN

Knie hefboom persen bereiken de max. kracht 1mm voor het einde van de slag

## De voordelen

- Hoge kracht bij minimale input
- Ergonomisch vanwege instelbare handel
- Nauwkeurigheid vanwege ram geleiding
- Nauwkeurig gefreesd tafelbed incl. 2 bevestigingspunten t.b.v. werkstukken.
- Boring tafelbed geeft vele mogelijkheden

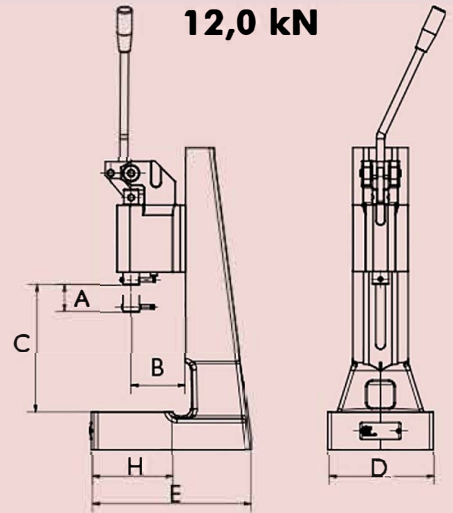
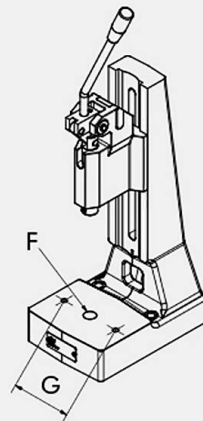

Ideaal geschikt voor assemblagewerkzaamheden, afbramen, ponsen, klinken, zetten, inpers- en buigwerkzaamheden



Type			CL 500 K	CL 750 K	CL 1200 K
Perskracht	kN		5,0	7,5	12,0
Arbeidsslag	mm	A	40	40	44
Uitlading	mm	B	63	80	80
Werkhoogte	mm	C	45-220	50-260	53-230
Afm. tafelbed	mm	DxH	110x60	157x115	157x115
Boring tafelbed Ø	mm	F	20	20	20
Bevestigingsgaten			2 x M 8	2 x M 10	2 x M 10
Afstand schroefdraad	mm	G	66	108	108
Boring ram Ø x diepte	mm		10 <sup>H7</sup> x 25	10 <sup>H7</sup> x 25	10 <sup>H7</sup> x 30
Ram Ø			20	24	30
Benodigde ruimte	mm	DxE	110x160	157x237	157x237
Gewicht	ca. kg		8,5	21	24

CAD-bestanden zijn op aanvraag beschikbaar

\* \*Indien correct gebruikt  
(excl. slijtgedelen)

www.bibus.nl