

# BJD-HL

## FEATURES

- High/Low Pressure Alarm
- Quick & Easy Installation
- Retrofit on Existing Application
- Compact Design
- IP45 rated Beacon

## Dimensions

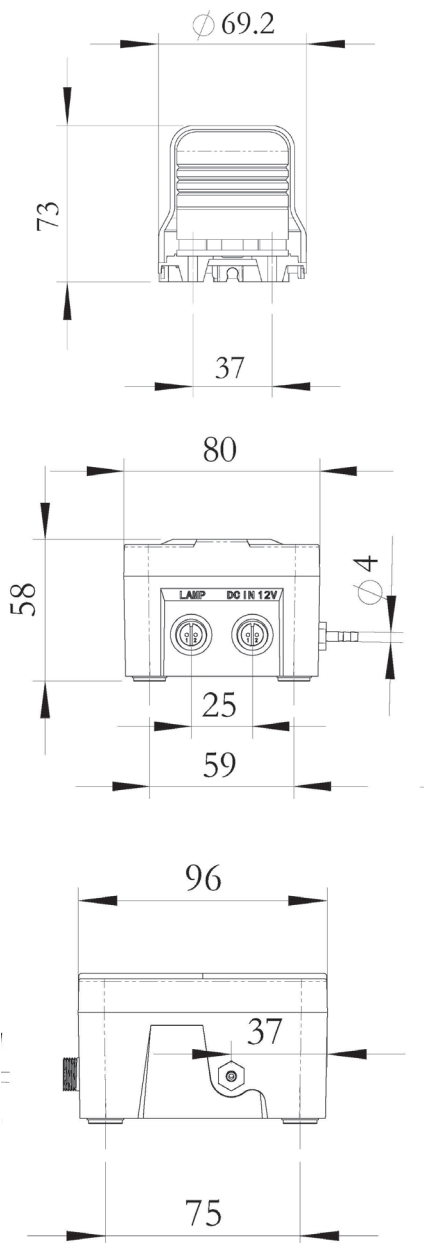

## Technical Data

MODEL		BJD-HL
Frequency	Hz	50/60
Alarm Pressure HIGH	kPa	>25
Alarm Pressure LOW	kPa	<7
Voltage	VAC	100-240
Power Consumption	W	3
Noise Level	dB(A)	70
Net Weight	kg	0.9

All specification values are for reference only, and are not guaranteed values.

## Design Idea

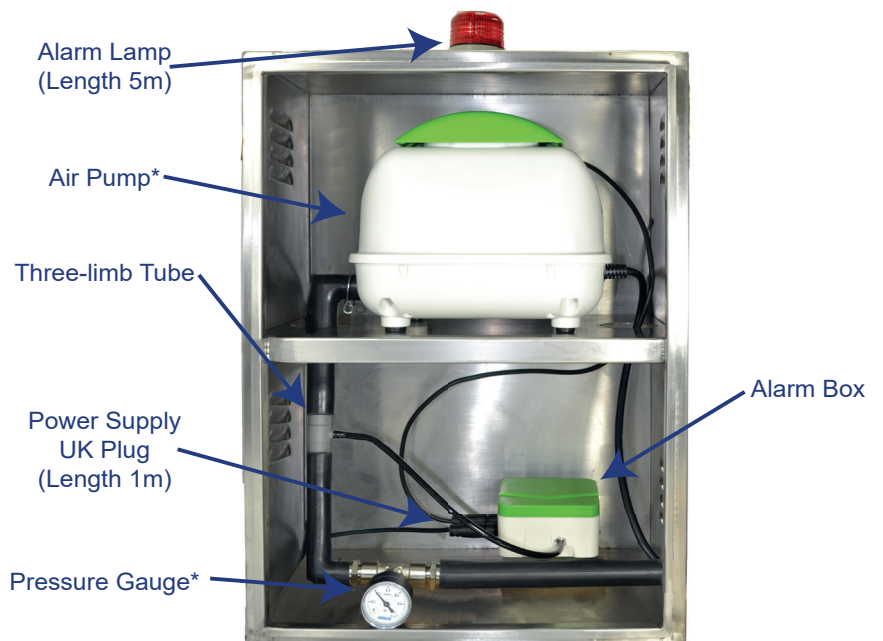

\*not included