

# Flat rods ver. D

## Grip handle 1C.904

### FLAT ROD ver. D

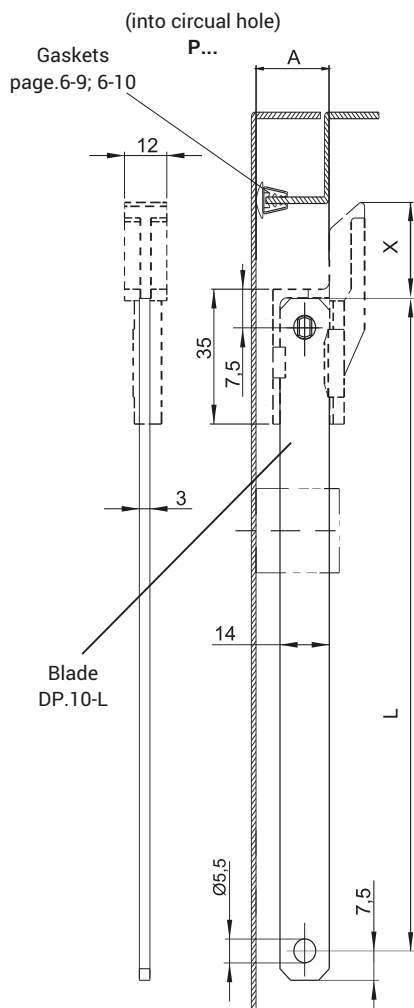

(into square hole)  
PK...

Grip handle  
904.053; X=24,4  
904.054; X=14,4

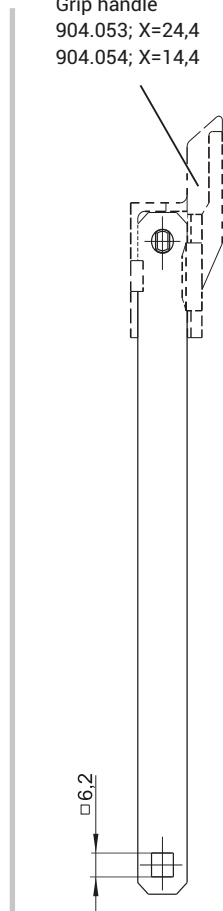

(into shape hole)  
PP...

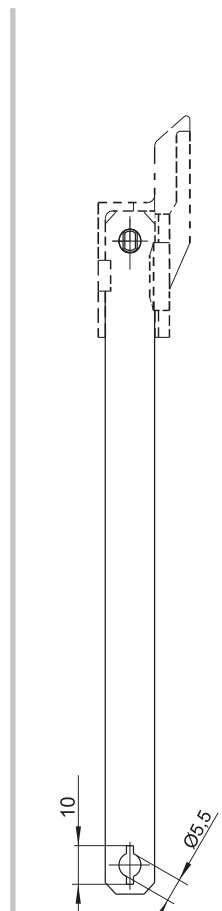

**GRIP HANDLE**  
1C.904.053

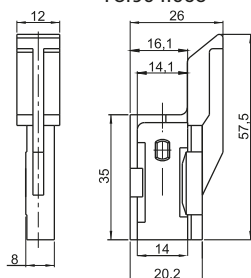

**GRIP HANDLE**  
1C.904.054

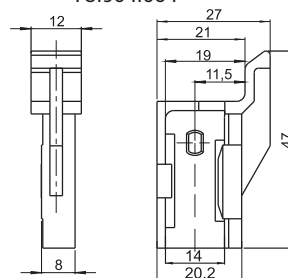

CAT. NUMBER		NAME	DIMENSION		MATERIAL
Steel zinc plated	Steel 1.4301		L		
DP.01 - L	DP.02 - L	Band pressing into circular hole	400	Other dimensions to be agreed	Band pressing - steel zinc plated, stainless steel
DPK.01 - L	DPK.02 - L	Band pressing into square hole	500		
			600		
			700		
			800		
DPP.01 - L	DPP.02 - L	Band pressing into shaped hole	900		
			1000		
			A		
1C.904.053		Grip handle	17,5		PA-6 RAL9005
1C.904.054			22,5		

• **Order example:** A23K-300 means band pressing 3x14mm, dimension A=23, length of L=300mm into square

• **Capability** of execution flat according to individual orders