

# COVAL

vacuum managers

---

## FPC

FlowPack Suction Cups



## ADVANCED VACUUM SOLUTIONS

Focusing on the needs of its customers in the food industry, COVAL has developed a series of particularly innovative silicone cups, dedicated to the high-speed handling of flexible packaging.

Combining great flexibility and food compatibility, the new **FPC Series** suction cups have been specially designed to optimize the handling of packed bags **from 100 g to 5 kg**. E.g. - **FlowPack, DoyPack**, etc.



Industry-specific applications



Types of use



### A Collection of Innovations

The shape of the lip has been designed to match the deformation of flexible packaging and ensure the best possible seal during positioning; which, as an additional advantage, allows for a reduction in power of the vacuum generator. The FPC suction cups are also equipped with cleats that stiffen the lip and reinforce the clamping effect.

- ❶ **Thin and wavy flower-shaped lips** that perfectly mold to the packaging, whatever the shape.
- ❷ **Internal cleats** that allow for optimized vacuum while preventing any crushing and also strengthen the hold on the product being handled.
- ❸ **Fittings featuring a lateral vacuum distributor** that prevent any loss in efficiency when the product is held.
- ❹ **Materials: Food-grade** silicone and plastic insert meets FDA and CE standards.

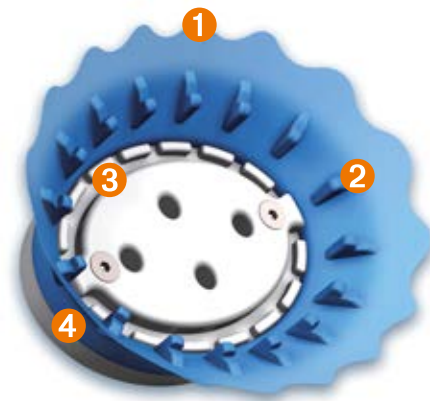

### Advantages

#### WITHSTANDS HIGH PRODUCTION RATES:

- Its gripping ability allows for high production rates.
- No interruption in the packaging line due to faulty gripping.

#### SAFETY:

- The FPC Series suction cup is made of silicone, a material that is recommended for its temperature resistance and food safety. The plastic fittings also conform to food standards.

#### ENERGY SAVINGS:

- The airtightness of FPC Series suction cups avoids the need for an oversized vacuum generator, allowing for considerable energy savings.

#### SUITABLE FOR ALL FLOWPACKS:

- Different forms and dimensions for a suitable solution.

### A Complete Range

#### AVAILABLE IN FOUR SIZES:

- Round, Ø 35 mm, 1.5 bellows.
- Round, Ø 45 and 60 mm.
- Elliptical, 120 x 100 mm.

#### TWO LEVELS OF FLEXIBILITY:

- 35 and 50 Shore.

#### MATERIALS:

FPC suction cups are compatible with FDA food standards (FDA 21 CFR 177.2600.) and meet the European regulation (EC) 1935/2004.

- **Suction cups:** Silicone.
- **Fittings:** Plastic POM-C and PETP.
- **Flat Seal:** Silicone.
- **Screw:** Stainless Steel.







#### FPC VIDEO

Discover the FPC suction cups in action!





	Dim. (mm)	 (cm <sup>3</sup> )	 (N) <sup>(1)</sup>	Shore Hard- ness	 (g)	ØA (mm)	ØD (mm)	L (mm)	I (mm)	f <sup>(2)</sup> (mm)	H (mm)	H1 (mm)	ØG (mm)	E 
FPC351.5SIBL3IF14PC	Ø 35	7.2	5	35	9.9	35	23	/	/	10	29	36	G1/4"-F	19
FPC351.5SIBL5IF14PC	Ø 35	7.2	5	50	9.9	35	23	/	/	10	29	36	G1/4"-F	19
FPC45SIBL3IF38PC	Ø 45	13	10	35	20	45	39	/	/	7	23	30	G3/8"-F	26
FPC45SIBL5IF38PC	Ø 45	13	10	50	20	45	39	/	/	7	23	30	G3/8"-F	26
FPC60SIBL3IF38PC	Ø 60	24.5	15	35	21.5	60	40	/	/	10	26	33	G3/8"-F	26
FPC60SIBL5IF38PC	Ø 60	24.5	15	50	21.5	60	40	/	/	10	26	33	G3/8"-F	26
FPC120100SIBL3IF38P1V	120x100	167	50	35	92.1	/	/	120	100	15	32.5	42.5	G3/8"-F	/
FPC120100SIBL5IF38P1V	120x100	167	50	50	92.1	/	/	120	100	15	32.5	42.5	G3/8"-F	/

(1) Force measured at 65% vacuum, without safety factor.  
(2) f = deflection of the suction cup.

### Dimensions "Suction Cup + Fitting"

#### FPC351.5...IF14PC

Round, Ø 35 mm, 1.5 bellows

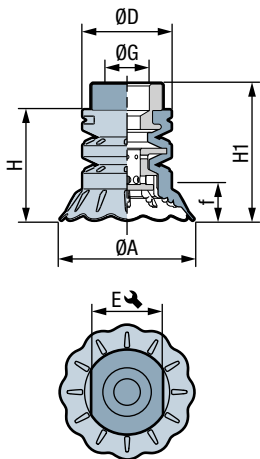

#### FPC45...IF38PC

Round, Ø 45 and 60 mm

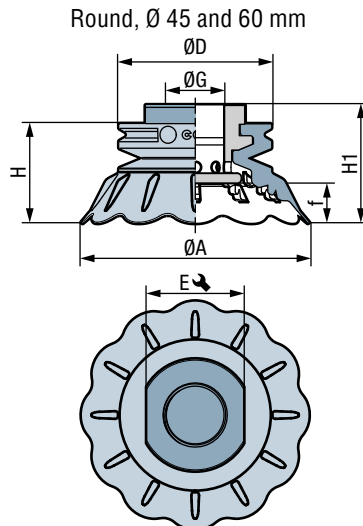

#### FPC120100...IF38P1V

Elliptical, 120 x 100 mm

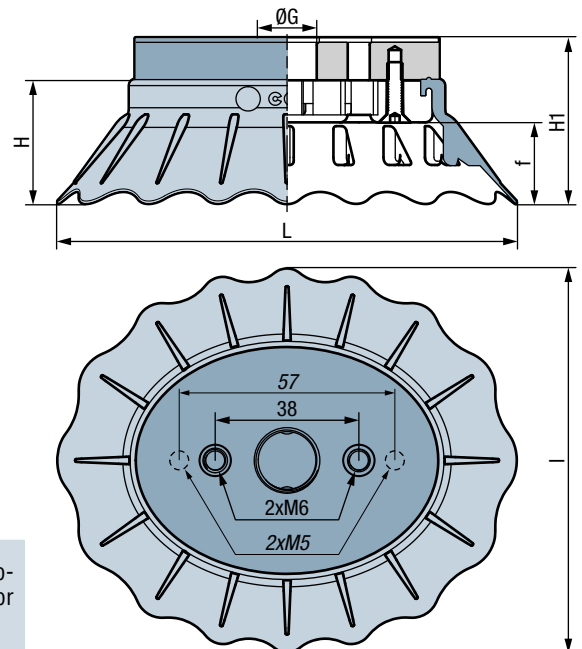

**3D**  
**COVAL Data**

On our site [www.coval.com](http://www.coval.com) you will find 3D models of all our products, in formats suitable for the principal CAD software.

### Mounting Configurations

#### FPC351.5/FPC45/FPC60

Via connection:

- FPC351.5: G 1/4"-F
- FPC45/FPC60: G 3/8"-F



#### FPC120100

From below:

- 2 M5x20 screws (not included).



From above:

- 2 M6x16 screws (not included).



## Universal FlowPack Suction Cups

To Order



### FPC351.5 Round, Ø 35 mm, 1.5 bellows

#### COMPLETE PART CONFIGURATION

- SUCTION CUP
- + UPPER G1/4"-F FITTING
- + LOWER PLATE:

- Hardness 35 Shore  
**FPC351.5SIBL3IF14PC**
- Hardness 50 Shore  
**FPC351.5SIBL5IF14PC**



#### INDIVIDUAL PART REFERENCE

UPPER G1/4"-F FITTING ONLY:  
**IF14PFPC35**

SUCTION CUP ONLY:  
▪ Hardness 35 Shore  
**FPC351.5SIBL3**  
▪ Hardness 50 Shore  
**FPC351.5SIBL5**

LOWER PLATE ONLY:  
**IL1PFPC35**

### FPC45/FPC60 Round, Ø 45 and 60 mm

#### COMPLETE PART CONFIGURATION

- SUCTION CUP
- + G3/8"-F FITTING:

#### FPC45

- Hardness 35 Shore  
**FPC45SIBL3IF38PC**
- Hardness 50 Shore  
**FPC45SIBL5IF38PC**

#### FPC60

- Hardness 35 Shore  
**FPC60SIBL3IF38PC**
- Hardness 50 Shore  
**FPC60SIBL5IF38PC**



#### INDIVIDUAL PART REFERENCE

INSERT G3/8"-F SEUL :  
**IF38PFPC60**

**FPC45**  
SUCTION CUP ONLY:  
▪ Hardness 35 Shore  
**FPC45SIBL3**  
▪ Hardness 50 Shore  
**FPC45SIBL5**

**FPC60**  
SUCTION CUP ONLY:  
▪ Hardness 35 Shore  
**FPC60SIBL3**  
▪ Hardness 50 Shore  
**FPC60SIBL5**

### FPC120100 Elliptical, 120 x 100 mm

#### COMPLETE PART CONFIGURATION

- SUCTION CUP
- + LOWER PLATE
- + UPPER PLATE G3/8"-F
- + FLAT SEAL:

- Hardness 35 Shore  
**FPC120100SIBL3IF38P1V**
- Hardness 50 Shore  
**FPC120100SIBL5IF38P1V**



#### INDIVIDUAL PART REFERENCE

UPPER PLATE G3/8"-F + FLAT SEAL:  
**IF38PFPC120**

SUCTION CUP ONLY:  
▪ Hardness 35 Shore  
**FPC120100SIBL3**  
▪ Hardness 50 Shore  
**FPC120100SIBL5**

LOWER PLATE + 2 STAINLESS SCREWS  
M4x16: **IL1PFPC120**

Standard configurations (suction cup + fitting) are delivered unassembled.



# FPC

## Universal FlowPack Suction Cups

### Applications



The FPC series suction cups are dedicated to the handling of flexible packaging such as FlowPack, Doypack, etc.

- FlowPack < 0.5 kg: suction cup Ø 35 mm, FPC351.5.
- FlowPack < 1 kg: suction cup Ø 45 mm, FPC45.
- FlowPack < 1.5 kg: suction cup Ø 60 mm, FPC60.
- FlowPack ≤ 5 kg: oval suction cup 120x100 mm, FPC120100.





**COVAL**  
vacuum managers

vacuum  
**components**



**A TECHNOLOGICAL PARTNER ON A GLOBAL SCALE**

Located in the southeast region of France, COVAL conceives, manufactures and globally distributes high performance, advanced vacuum automation components and systems for industrial applications in all branches.

COVAL is an ISO 9001: V2015 certified company which offers innovative solutions integrating reliable and optimized components with intelligent functionalities. The focus is to provide the most personalized and economic solution to a given application while assuring a significant improvement in the productivity and the safety for the vacuum users around the world.

COVAL has an ambition for technical excellence and innovation. As a specialist in vacuum automation, COVAL is reputed for offering reliable, personalized, cost effective and productive solutions.

The references of COVAL can be found in several industrial sectors (Packaging, Automotive Industry, Plastic, Graphic, Aeronautic...) where vacuum handling is important for high efficiency and productivity.

COVAL markets its products and services all over Europe, in the United States and South America through its subsidiaries and authorized distribution network. COVAL strives to provide customer driven solutions and gives the best possible treatment to satisfy all its clients.

*For all enquiries from Australia, Africa and Asia kindly contact COVAL head office in France.*



**COVAL S.A.S.**  
Head Office



**COVAL INC.**



**COVAL IBERICA**



**COVAL GERMANY**



**COVAL ITALIA**



**COVAL CHINA**

Distributed by:



certified quality  
management system

COVAL S.A.S.  
Head Office  
ZA Les Petits Champs  
10 allée Jean-Baptiste Venturi  
26120 Montélier France  
Tel : +33 (0)4 75 59 91 91  
Fax : +33 (0)4 75 59 91 05

[www.coval.com](http://www.coval.com)