

VPR

Suction Cups for Mailing Applications

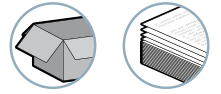

Industry-specific applications



Types of use



The COVAL range of mailing application suction cups is designed to meet the requirements of the mailing industry. The improved characteristics mean you can optimize production equipment in your branch, such as:

- Envelope stuffing
- Film wrapping
- Envelope insertion
- Mailing (picking).

Material

NR Natural rubber

3

VPR

Advantages

- Longer life expectancy
- Optimized for high throughput rates
- Excellent resistance to abrasion and slipping
- 100% compatible with machines currently on the market

Suction Cup Characteristics

	ØA	H	Ød	Ød1	ØD	B	Color	NR
VPR 001	24.4	15	5.9	7.8	13.8	8	green	VPR001NR
VPR 002	25.7	14.5	5.9	7.8	14	9	brown	VPR002NR
VPR 003	20	14.2	5.7	4	13.8	6	red	VPR003NR
VPR 004	20	14.2	5.7	5	14.8	6	black	VPR004NR

VPR 001 - 002

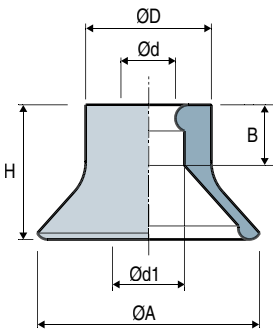

VPR 003 - 004

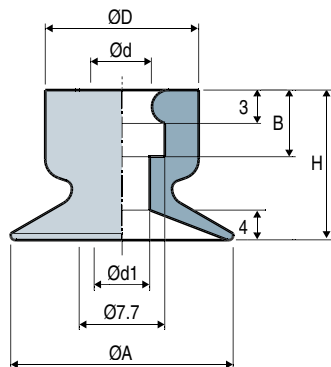

The values represent the average characteristics of our products.
Note: All dimensions are in mm



Specify the part number e.g.: VPR003NR
Please refer to the characteristics table above