

LOCK TYPE	VERSION	COMPONENTS	MATERIAL				
RS715.N	Cap 1C.902.001	Body, Handle	Polyamide				
RS715.M	Cogwheel mechanism MZ		Polyamide				
KEY CODE					FINISH [c]		
1333	405E	455E	1242E	2342E	RK	RAL 9005 07	RAL 7035 08

**How to order :**

Lock type  
Key code  
Finish

RS715.M — 1333 — [C]

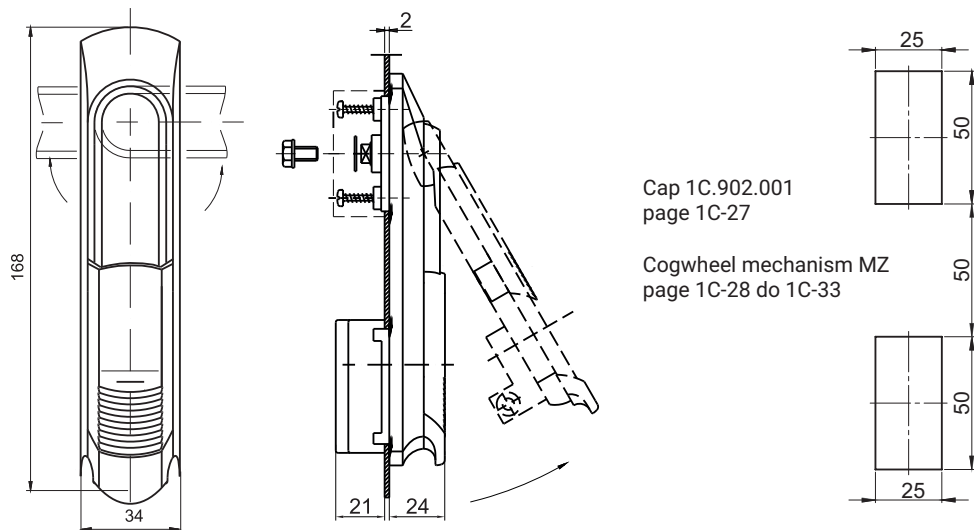

Cap 1C.902.001  
page 1C-27

Cogwheel mechanism MZ  
page 1C-28 do 1C-33

LOCK TYPE	VERSION	COMPONENTS	MATERIAL					
RS716.N	Cap 1C.902.001	Body, Handle	Polyamide					
RS716.M	Cogwheel mechanism MZ		Polyamide					
PIN					FINISH [c]			
							RAL 9005 07	RAL 7035 08

**How to order :**

Lock type  
Pin type  
Finish

RS716.N — T9 — [C]

\*possibility to make company logo on handle