

**Wörner**

# Stopping and positioning modules for automation technology

Product overview – 2022

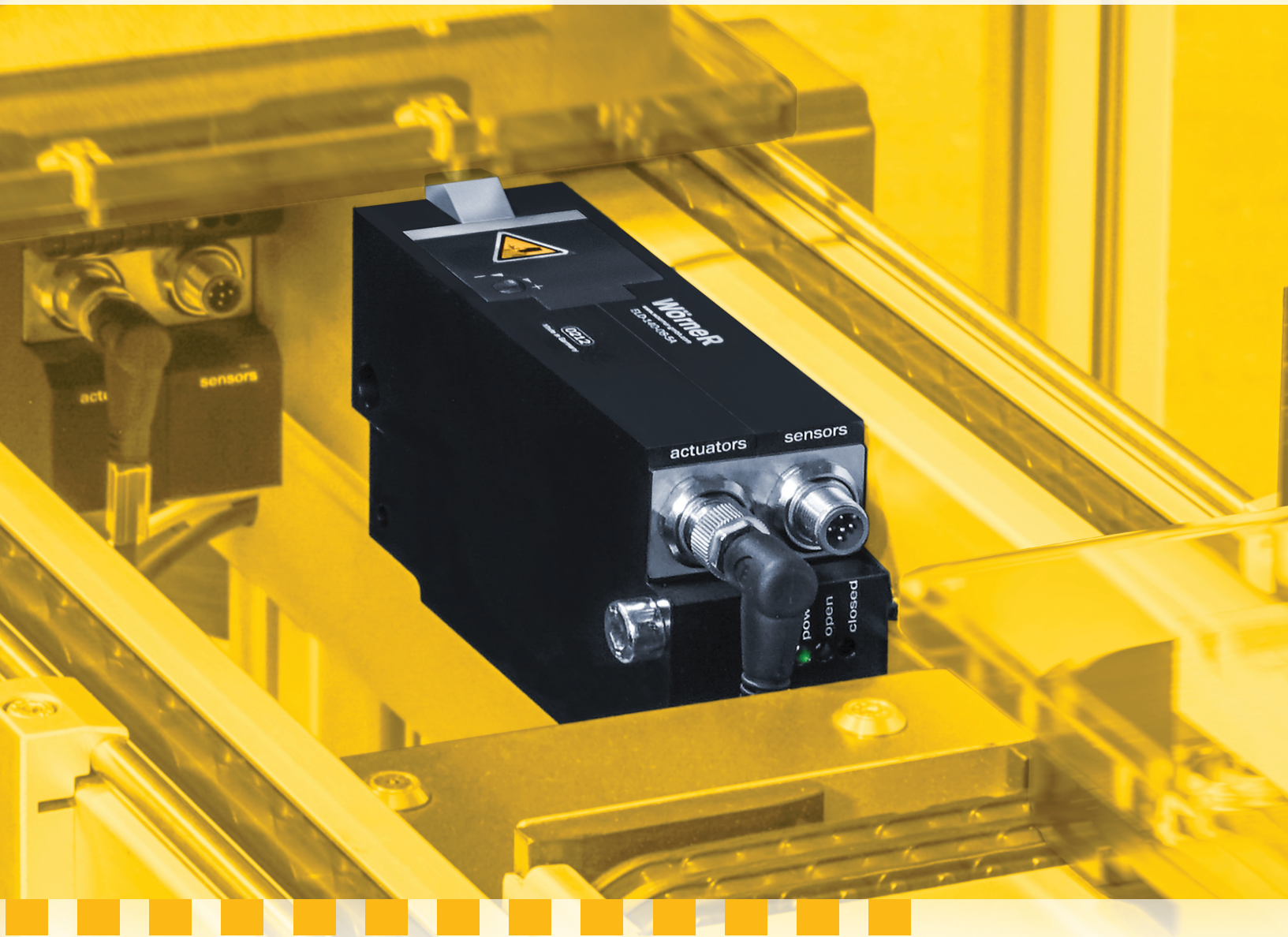

**Der Wörner-Stopper. Das Original.**

# Electric stoppers for every requirement

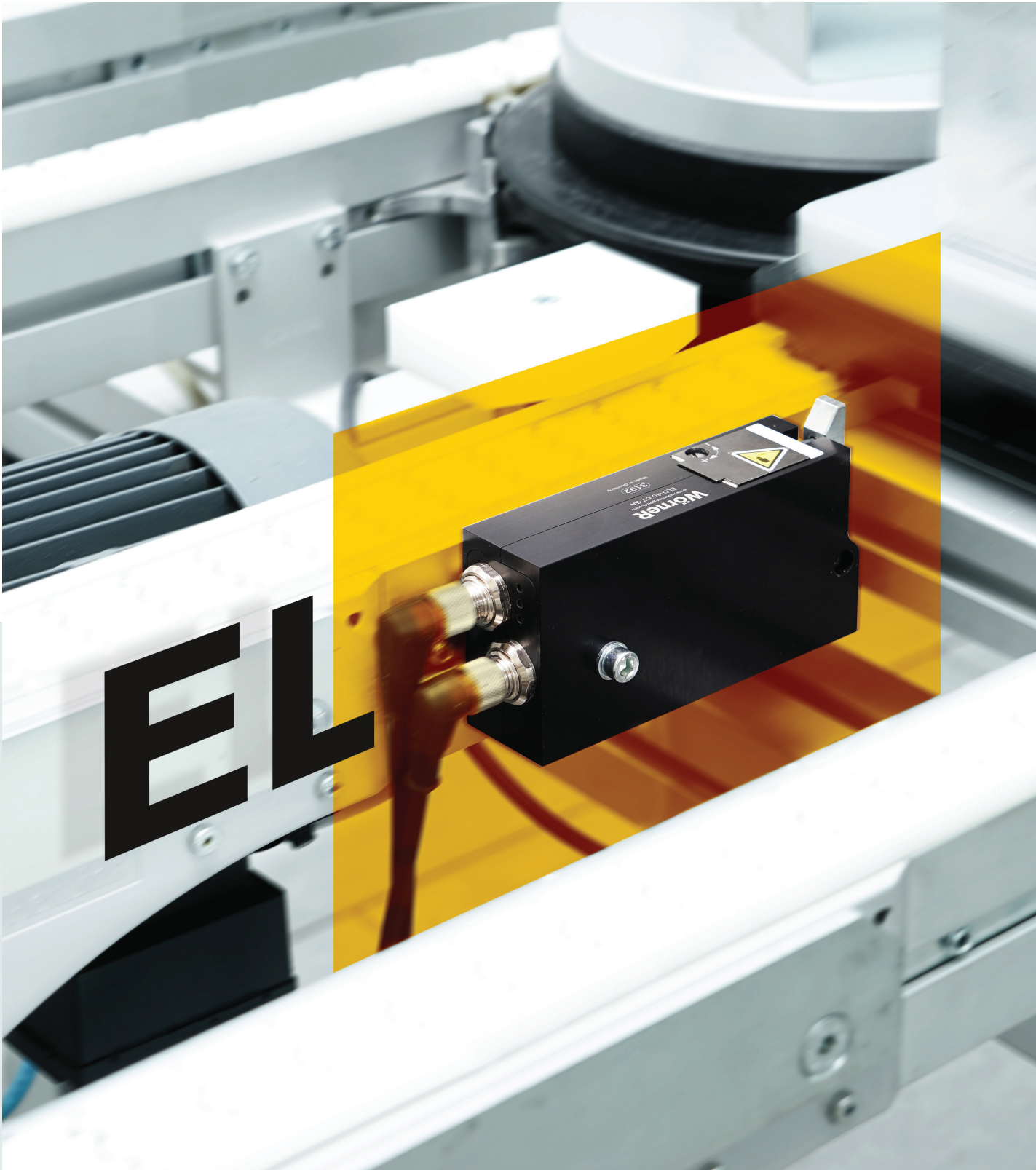

## Extensive product family: Electric stoppers with highest efficiency

Electrically driven stoppers provide numerous advantages:

- more than 70 % higher efficiency (compared to pneumatic systems)
- low operating costs
- minimal installation expenditure
- integrated sensors
- simple control of material flow
- low noise

Wörner electric stoppers are engineered to meet the requirements of a vast range of industries, with a proven track record in countless industrial automation applications.

Transport speed, pallet weight and robustness parameters determine the selection of the suitable Wörner component.

 You will find the stoppers of the proven ELD line starting on page 18.

## Electric stoppers in a new variety



ELD-40



ELD-140

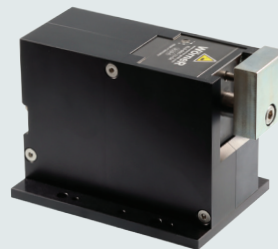

ELD-660



ELD-70



ELD-195



ELD-430



# Damping, stopping, positioning: The right solution for every requirement

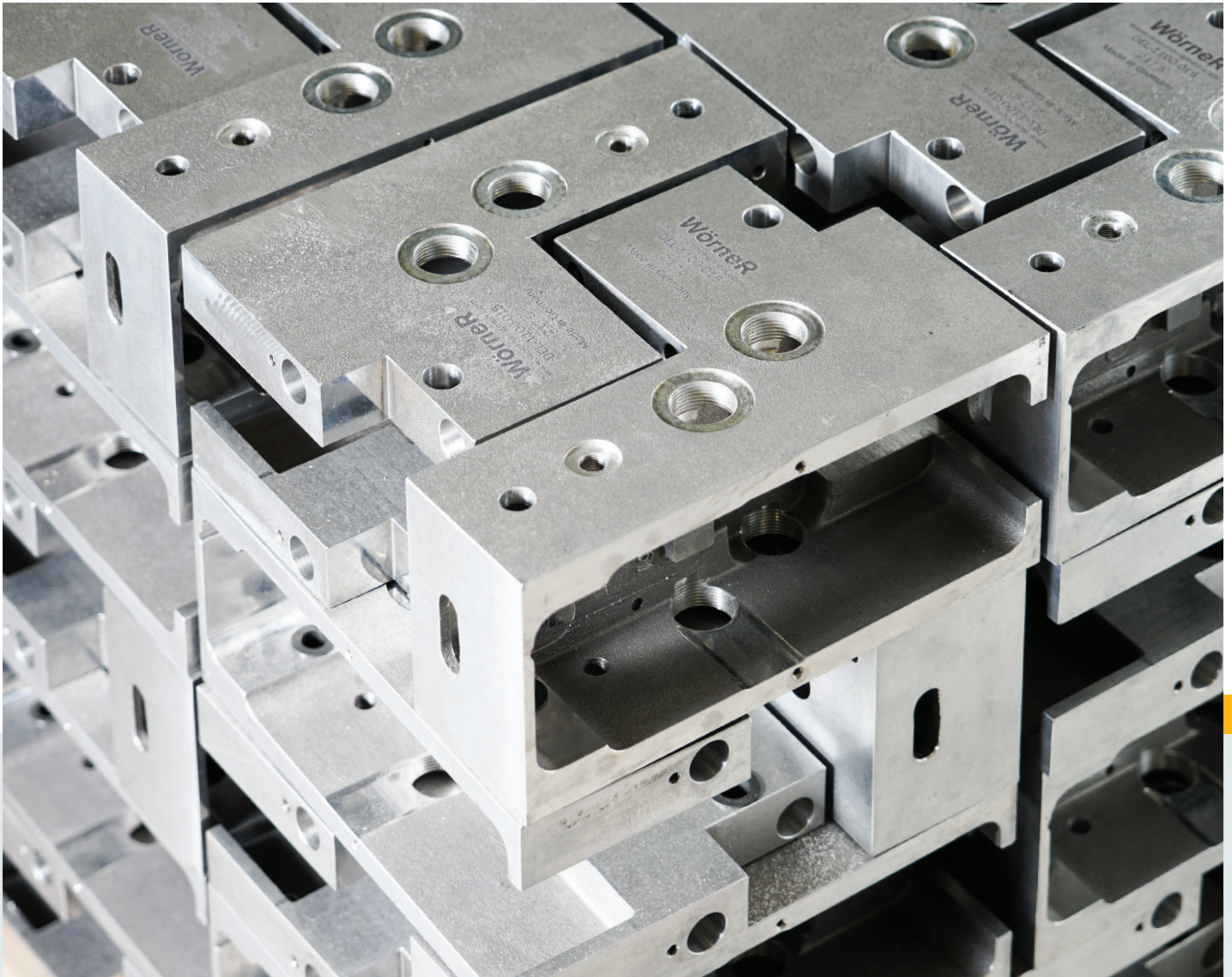

## From a simple workshop ...

The success story of our stoppers is based on the brilliant idea of the creative mind Helmut Wörner. The technology was patented in Germany 1990, from there the triumph takes its course: Within Europe and soon also internationally.

Today, Wörner stoppers are well-known around the globe. They are in fact a synonym for precision, durability and a safe investment.

*The first industrial stopper, the  
Wörner Delta „SDEH-5000“ (1986)*



## ... to an international specialist for leading-edge stoppers

Wörner's product portfolio covers more than 2.500 components: stoppers, angle dampers, index cylinders and anti-bounce stops are successfully applied in all conventional assembly and conveyor systems in a large variety of industrial sectors.

Experience grown over decades, excellent industry know-how and a modern, highly specialized machine park guarantee that even unusual customer demands can be satisfied.

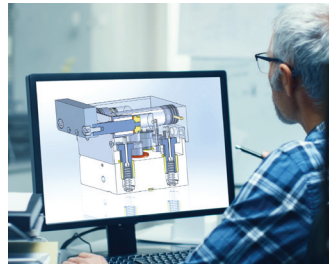

## New, custom solutions through close collaboration

We welcome the chance to put our skills to the test with special tasks: The Wörner expert team generates solutions for any requirement – either from the existing product range of standard products or by designing a tailor-made solution in close cooperation with the customer.



# Uncompromising quality and performance

## Wörner products “Made in Germany” ...

Wörner has always been committed to an effective quality management system.

The entire Wörner staff is dedicated to achieve our most important goals: providing top performance for the highest quality of all products and services, achieving greatest customer satisfaction and ensuring competitiveness.



*Component coordinate-measuring*

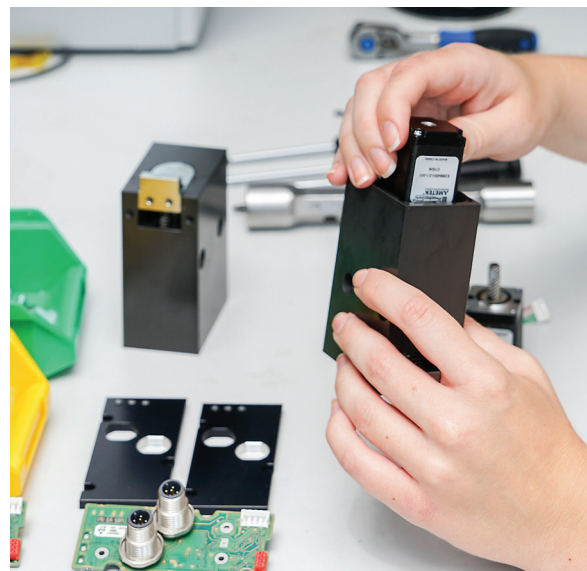

*Electrical stopper assembly*

### Wörner components for automated assembly, handling and manufacturing

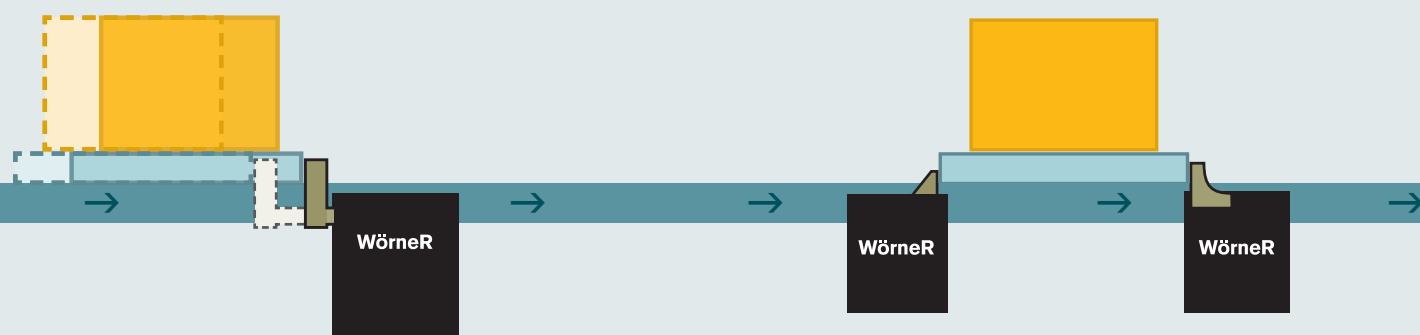

#### **Damped stoppers**

For shock-sensitive, fragile parts. Pallets are gently decelerated as they arrive so that workpieces reach their final position without rebound.

#### **Anti-bounce stops**

Anti-bounce stops hold the pallet loaded with individual parts in position with absolute precision to prevent any rebound.

#### **Undamped stoppers**

The tough, economical basic design. Suitable for use wherever one or more pallets are to be accumulated at a defined position.

## ... successfully applied all over the world

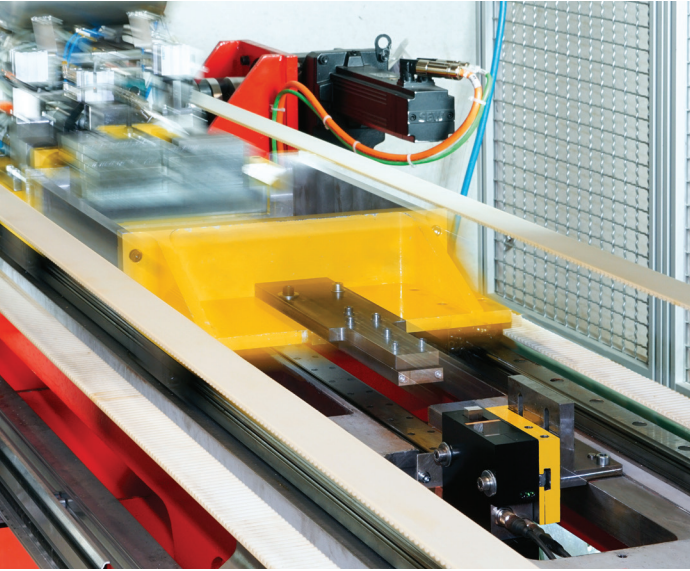

Endurance testing

Wörner's quality and environmental management systems are successfully certified in accordance to the international standards DIN ISO 9001 and ISO 14001. When developing new products, they have to pass extensive endurance tests. After assembly, every single unit goes through a final inspection.



Packaging and shipping

Before any component leaves the factory, it is carefully packed. Through the international distribution network, Wörner products and services are available world wide.

Before any component leaves the factory, it is carefully packed. Through the international distribution network, Wörner products and services are available world wide.

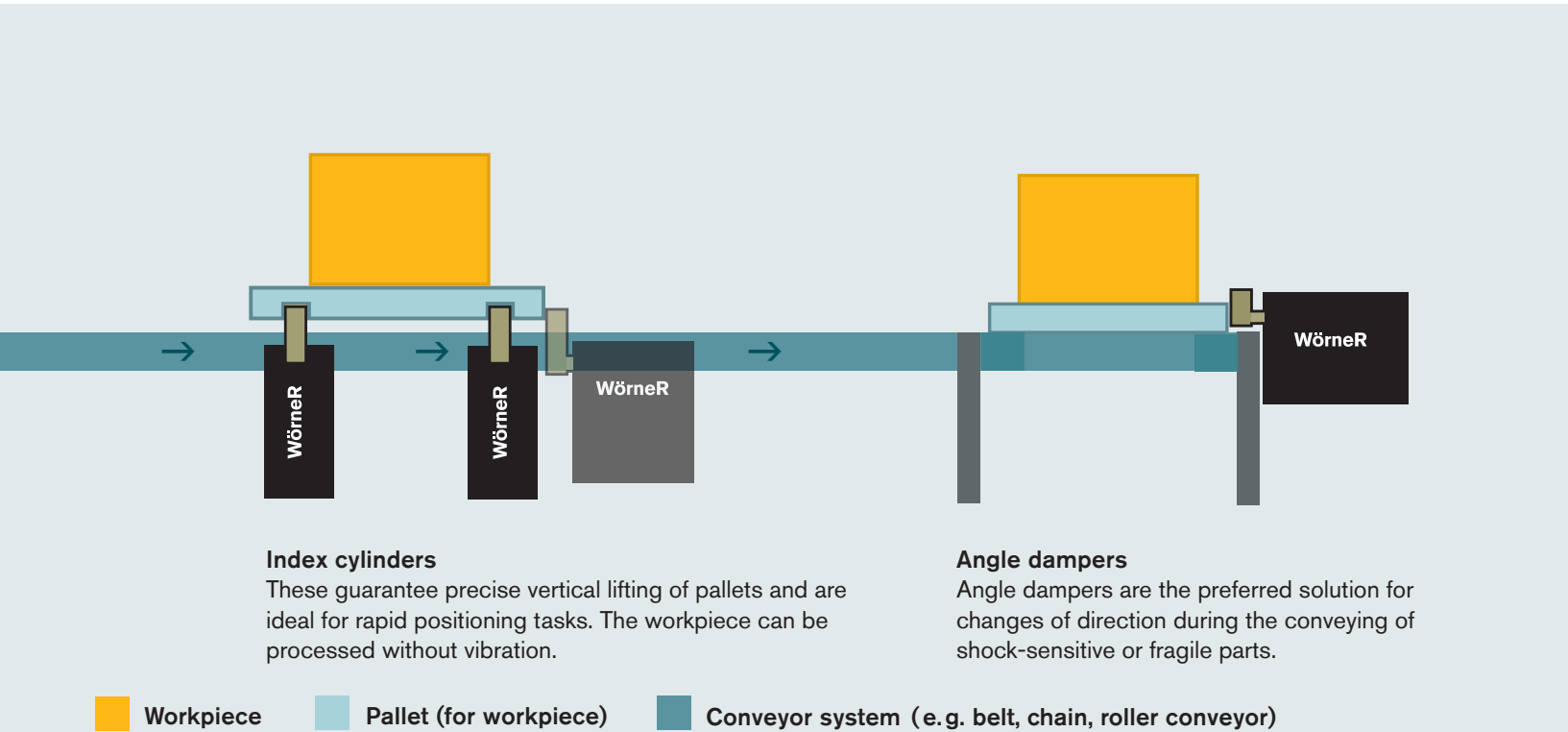

# Product overview



## The easy way to find the right product:

First of all, choose the **product family** and **product group**.

Then look for the corresponding **basic product** in the relevant table.

You can find the right **product variant** for your system using the data sheet associated with each basic product.

Please also refer to the technical explanations on pages 32/33.

The name of the product variant also serves as its order code (see notes on page 34).

If you need help identifying the variant you need, just get in touch with our service hotline:

Phone: +49 711 601 609 0

E-mail: [sales@woerner-gmbh.com](mailto:sales@woerner-gmbh.com)

### A Wörner core competence:

## Custom solutions based on customer requirements

In addition to our proven standard products, we offer a variety of custom-built special solutions. You will find examples of these on the following pages under “**Custom-built ...**”.

Just contact us if your project involves special requirements and requires a specific solution!

## Product family

### Stoppers

Stopping and clearing

### Angle dampers

Stopping with change of direction

### Index cylinders

Raising and positioning

### Anti-bounce stops

Preventing rebound

### Accessories

Adapting products and extending their functionality



## Product group

Page

<b>Pneumatic undamped stoppers</b>	<b>D0 / PNU</b>	10
<b>Pneumatic damped stoppers</b>	<b>DBS / PND</b>	13
<b>Electric undamped stoppers</b>	<b>DEL0 / ELU</b>	18
<b>Electric damped stoppers</b>	<b>DEL / ELD</b>	19
<b>Pneumatic damped stoppers for roller systems</b>	<b>DBSR</b>	22
<b>Accelleration Units</b>	<b>DAU</b>	24
<b>Displacement Stops</b>	<b>DDU/DDS</b>	25
<b>Pneumatic /electric angle dampers</b>	<b>DBSQ/ELDQ</b>	26
<b>Pneumatic index cylinders</b>	<b>DI / DIA</b>	28
<b>Pneumatic /electric anti-bounce stops</b>	<b>DR / DRP / DRE</b>	29

# Pneumatic undamped stoppers

	<i>Basic product</i>	<i>Lowering stroke</i>	<i>Damping stroke</i>	<i>max. propelling force</i>	<i>Scope of application*</i>		<i>Variants</i>
					at	Weight	
	<b>D0-70</b>	7 mm	n/a	48 N	06 m/min 09 12 18 24 30 36	70 kg 50 25 12 7 4 3	EW/DW H/K I/E cust.-spec. solutions var. access.
	<b>D0-120</b>	9 mm	n/a	82 N	06 m/min 09 12 18 24 30 36	120 kg 100 100 100 50 30 20	EW/DW H/K I/E cust.-spec. solutions var. access.
	<b>D0-140</b>	8 mm	n/a	96 N	06 m/min 09 12 18 24 30 36	140 kg 120 100 100 50 30 25	EW/DW H/K I cust.-spec. solutions var. access.
	<b>D0-200</b>	13 mm	n/a	206 N**	06 m/min 09 12 18 24	200 kg** 150** 120** 100** 60**	EW/DW H/K E W50/W90 cust.-spec. solutions var. access.
	<b>D0-300</b>	50 mm	n/a	206 N	06 m/min 09 12 18 24 30 36	300 kg 225 125 60 35 20 15	DW H/K cust.-spec. solutions var. access.

EW single-acting  
DW double-acting  
H/H2 heat-resistant  
K cold-resistant

I prepared for inductive  
position sensor  
E prepared for electronic  
position sensor

G/KE stop plate with thread  
/Elastomer stop plate  
V extended stop plate  
W50 tilted stop plate 50°  
W90 tilted stop plate 90°

\* All specifications given for a  
coefficient of friction of  $\mu = 0.07$   
\*\* Scope of application depends on  
operating mode (EW/DW) and stop plate  
design (W50/W90), see data sheet

		<u>Basic product</u>	<u>Lowering stroke</u>	<u>Damping stroke</u>	<u>max. propelling force</u>	<u>Scope of application*</u>		<u>Variants</u>
						at	Weight	
		<b>PNU-395</b>	9 mm	n/a	275 N	06 m/min	400 kg	-
						09	300	
		<b>D0-400</b>	9 mm 15 mm 25 mm 40 mm	n/a	275 N	06 m/min	400 kg	EW/DW H/H2/K E G/V/KE cust.-spec. solutions var. access.
						09	300	
						12	250	
						18	200	
						24	110	
						30	65	
						36	50	
								
09	300							
12	250							
18	200							
24	110							
30	65							
36	50							
		<b>D0-810</b>	10 mm 20 mm	n/a	549 N			06 m/min
						09	810	
						12	810	
						18	810	
						24	450	
						30	250	
						36	250	

Note: The scope of application for undamped stoppers is highly dependent on the conditions of use, in particular on the coefficient of friction between the conveyor equipment and pallet and on the rigidity of the conveyor. We can provide you with detailed technical advice when making your choice - just ask us!

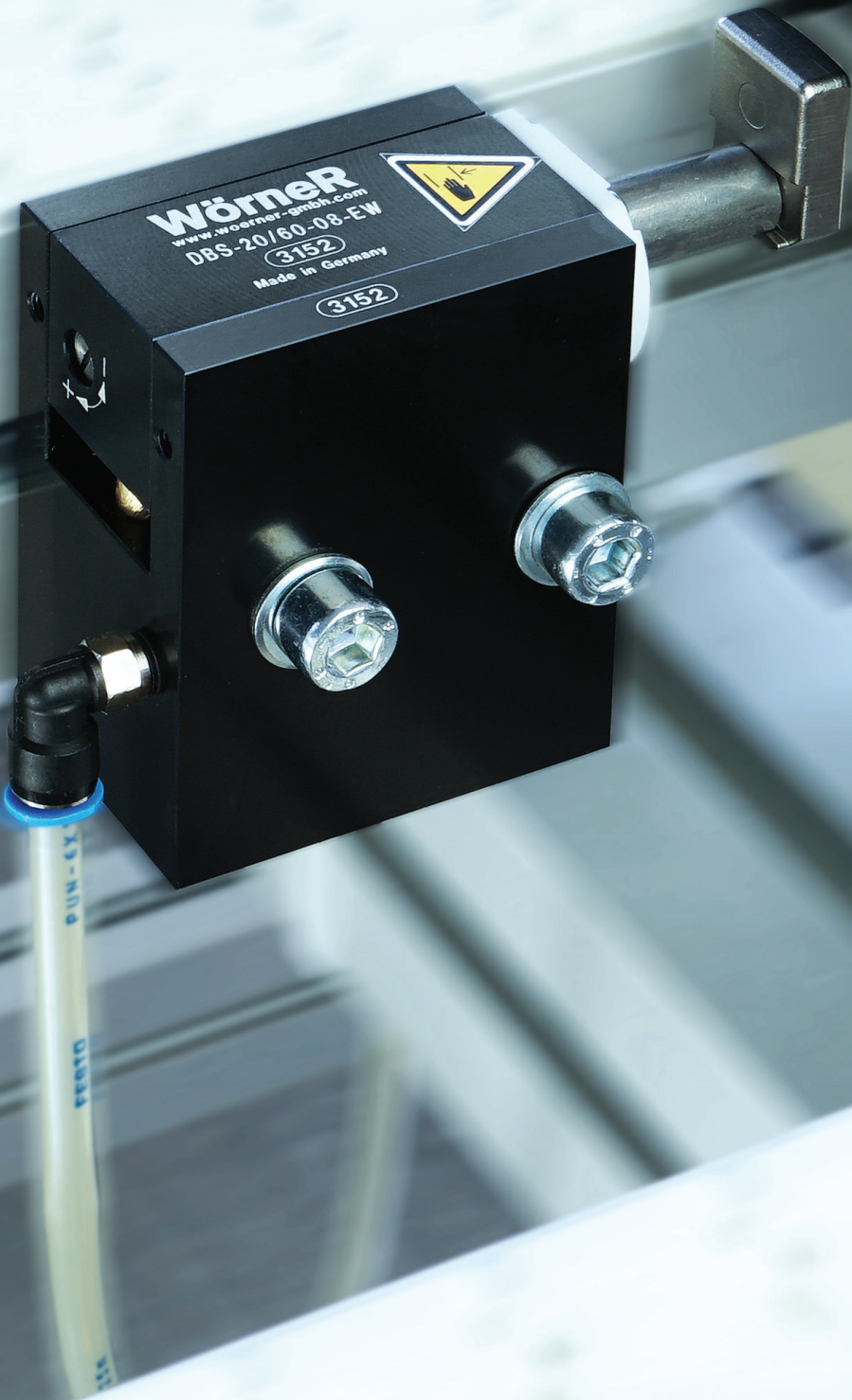





**Würmer**  
www.wuermer-gmbh.com  
DBS-20/60-08-EW  
3152  
Made in Germany  
3152



PUN-CY  
DBS20

## Pneumatic damped stoppers

	<u>Basic product</u>	Lowering stroke	Damping stroke	min./max. propelling	Scope of application*		<u>Variants</u>
					at	Weight	
	<b>DBS-18</b>	7 mm	10 mm	0,5 N/ 15 N	06 m/min 09 12 18 24 30 36	0,25-22 kg 0,25-20 0,25-13 0,25-7 0,25-4 0,25-3 0,25-2	EW/DW H/K I/E KU cust.-spec. solutions var. access.
	<b>DBS-20/60</b>	8 mm 13 mm	21.5 mm	2,5 N/ 100 N	06 m/min 09 12 18 24 30 36	3,5-60 kg 3,5-40 3,5-35 3,5-30 3,5-24 3,5-18 3,5-10	EW/DW H/H2/K E KI/KU/KA/V S cust.-spec. solutions var. access.
	<b>PND-67</b>	8 mm	24 mm	2,5 N/ 100 N	06 m/min 09 12 18 24 30 36	65 kg 3,5-44 3,5-38 3,5-33 3,5-26 3,5-19 3,5-11	KI
	<b>DBS-90</b>	8 mm 13 mm	30 mm	2,5 N/ 100 N	06 m/min 09 12 18 24 30 36	5-90 kg 5-70 5-60 5-50 5-40 5-30 5-22	EW/DW RD H/K E/I KI/KU/KA/V S
	<b>DBS-140</b>	8 mm	30 mm	2,5 N/ 160 N	06 m/min 09 12 18 24 30 36	5-150 kg 5-140 5-100 5- 80 5- 50 5- 40 5- 30	EW/DW H/K E cust.-spec. solutions var. access.

EW single-acting  
 DW double-acting  
 RD reduced damping stroke  
 H/H2 heat-resistant  
 K cold-resistant

I prepared for inductive position sensor  
 E prepared for electronic position sensor  
 KI tilt stop  
 KU plastic stop

KA plastic stop antistatic  
 V extended stop plate  
 S prepared for stop position sensing

\* All specifications given for a coefficient of friction of  $\mu = 0.07$

# Pneumatic damped stoppers

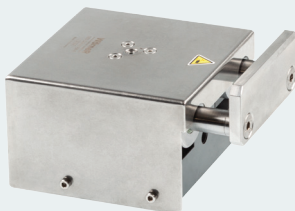
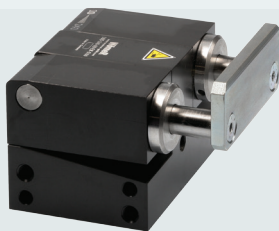
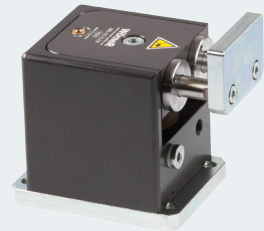





	<u>Basic product</u>	Lowering stroke	Damping stroke	min./max. propelling	Scope of application*		<u>Variants</u>
					at	Weight	
	<b>DBS-150</b>	15 mm	20 mm	3,5 N/ 180 N	06 m/min 09 12 18 24 30 36	5-170 kg 5-140 5-100 5- 80 5- 50 5- 40 5- 25	EW/DW H/K KI cust.-spec. solutions var. access.
	<b>DBS-150-T4</b>	11.5 mm	20 mm	3,5 N/ 130 N	06 m/min 09 12 18 24 30 36	150 kg 100 100 90 55 35 25	EW/DW H/K cust.-spec. solutions var. access.
	<b>DBS-170</b>	8 mm	27.5 mm	4 N/ 200 N	06 m/min 09 12 18 24 30 36	5-200 kg 5-160 5-145 5- 90 5- 55 5- 40 5- 30	EW/DW H/H2/K E KI/S19/S50 cust.-spec. solutions var. access.
	<b>DBS-240</b>	9 mm	24 mm	8 N/ 165 N	06 m/min 09 12 18 24 30 36	10-240 kg 10-220 10-200 10-180 10-110 10- 70 10- 50	EW/DW H/K KI/S20/S50/ S100 cust.-spec. solutions var. access.
	<b>DBS-240-R</b>	9 mm	24 mm	30 N/ 165 N	06 m/min 09 12 18 24 30 36	10-240 kg 10-220 10-200 10-180 10-110 10- 70 10- 50	EW/DW K rustproof cust.-spec. solutions var. access.

EW single-acting  
 DW double-acting  
 RD reduced damping stroke  
 H/H2 heat-resistant  
 K cold-resistant

I prepared for inductive  
 position sensor  
 E prepared for electronic  
 position sensor

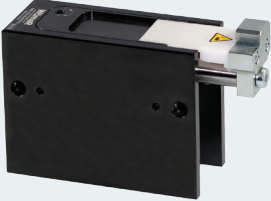
KI tilt stop  
 KU plastic stop  
 S prepared for stop  
 position sensing

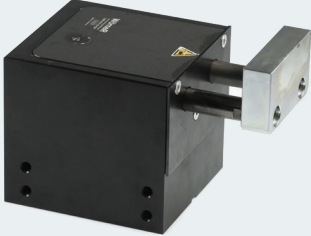
S19 steel stop, 19 mm wide  
 S20 steel stop, 20 mm wide  
 S21 steel stop, 21 mm wide

	<u>Basic product</u>	Lowering stroke	Damping stroke	min./max. propelling	Scope of application*		<u>Variants</u>
					at	Weight	
	<b>DBS-255</b>	9 mm	38 mm	3,5 N/ 300 N	06 m/min 09 12 18 24 30	270 kg 220 160 110 60 40	EW/DW H/K E S19/S35 cust.-spec. solutions var. access.
	<b>DBS-300</b>	11 mm	24 mm	8,3 N/ 206 N	06 m/min 09 12 18 24 30	12-300 kg 12-270 12-250 12-225 12-140 12- 95	EW/DW H/K I S cust.-spec. solutions var. access.
	<b>DBS-900</b>	15 mm	45,7 mm	6 N/ 700 N	06 m/min 09 12 18 24 30 36	900 kg 800 730 410 250 180 90	EW/DW RD H/K KI/KU S cust.-spec. solutions var. access.
	<b>DBS-1150</b>	15 mm	21 mm	30 N/ 700 N	09 m/min 12 18 24 30	700 kg** 750** 850** 550** 350 **	EW/DW KI/KU S cust.-spec. solutions var. access.
	<b>DBS-2000</b>	15 mm	25,4 mm	130 N/ 700 N	06 m/min 09 12 18 24 30	2000 kg** 1800** 1400** 1000** 650** 550**	EW/DW H/K KI/KU S cust.-spec. solutions var. access.

S35 steel stop, 35 mm wide  
S50 steel stop, 50 mm wide  
S100 steel stop., 100 mm wide

\* All specifications given for a coefficient of friction of  $\mu = 0.07$

\*\* Exceptionally, these values apply at a coefficient of friction of  $\mu = 0.02$

# Pneumatic damped stoppers



## Basic product

## Lowering stroke

## Damping stroke

## min./max. propelling

## Scope of application\*

## Variants

### DBS-3000

15 mm

46 mm

76 N/  
2060 N

at	Weight
09 m/min	110-3000 kg
12	110-3000
18	110-2350
24	110-1900

EW/DW  
S  
cust.-spec.  
solutions  
var. access.

### DBSS06-10

8 mm

6 mm

0,5 N/  
7 N

at	Weight
06 m/min	0.7-10 kg
09	0.7- 5
12	0.7- 5
18	0.7- 4
24	0.7- 2.4
30	0.7- 1.5
36	0.7- 1

EW/DW  
H/K  
KI/KU/KA  
I  
cust.-spec.  
solutions  
var. access.

### DBSS10-20

8 mm

10 mm

0,5 N/  
14 N

at	Weight
06 m/min	0.7-20 kg
09	0.7-10
12	0.7- 8
18	0.7- 6
24	0.7- 3.5
30	0.7- 2.5
36	0.7- 1,5

EW/DW  
H/K  
KI/KU/KA, I  
clean room  
ISO cl. 5  
cust.-spec.  
var. access.

### DBSSI-20

8 mm

14 mm

1 N/  
14 N

at	Weight
06 m/min	1-20 kg
09	1-15
12	1-12
18	1-10
24	1- 6
30	1- 4
36	1- 2.5

EW/DW  
H/K  
I  
cust.-spec.  
solutions  
var. access.



EW single-acting  
DW double-acting  
H heat-resistant  
K cold-resistant

I prepared for inductive  
position sensor  
KI tilt stop  
KU plastic stop  
KA plastic stop  
antistatic

S prepared for stop  
position sensing  
E prepared for electronic  
position sensor

\* All specifications given for a  
coefficient of friction of  $\mu = 0.07$

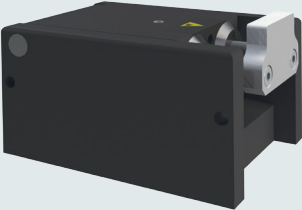

	<u>Basic product</u>	Lowering stroke	Damping stroke	min./max. propelling	Scope of application*		<u>Variants</u>
					at	Weight	
	<b>DBSST-35</b>	7 mm	15.2 mm	1 N/ 29 N	06 m/min 09 12 18 24 30 36	1 - 42 kg 1 - 28 1 - 24 1 - 18 1 - 17 1 - 12 1 - 7	EW/DW H/K cust.-spec. solutions var. access.
	<b>DBSST-130</b>	7 mm	18.3 mm	2 N/ 90 N	06 m/min 09 12 18 24 30 36	1 - 130 kg 1 - 90 1 - 77 1 - 60 1 - 40 1 - 38 1 - 20	EW/DW H/K cust.-spec. solutions var. access.
	<b>DBSU-150</b>	9 mm	22 mm	3,5 N/ 103 N	06 m/min 09 12 18 24 30 36	5-150 kg 5-100 5-100 5- 90 5- 55 5- 35 5- 25	EW/DW H/K KI cust.-spec. solutions var. access.
	<b>DBSU-270</b>	9 mm	25.5 mm	7 N/ 185 N	06 m/min 09 12 18 24 30 36	10-270 kg 10-220 10-200 10-180 10-110 10- 70 10- 50	EW/DW H/K E KI cust.-spec. solutions var. access.





### Custom-built:

#### DBS-1100-15-EW-011



With integrated anti-bounce stop designed to keep the pallet in position after the damping operation. A sealed cover that travels simultaneously with the damping unit protects the device against dirt and aggressive liquids. The solution also includes a retracted stop sensor (damping completed but mechanism still locked) and makes it possible to lock the stop in the lower position. Ideally suited for use in harsh environments, e.g. when linking machining centers in the automotive industry.

# Electric undamped stoppers / ■ Rotary Switch









	<i>Basic product</i>	<i>Lowering stroke</i>	<i>Damping stroke</i>	<i>min./max. propelling</i>	<i>Scope of application*</i>		<i>Variants</i>
					at	Weight	
	<b>DELO-65</b>	9 mm	n/a	-/ 65 N	06 m/min 09 12 18	65 kg 60 55 50	2x5-pin M12x1 plug KU R cust.-spec. solutions var. access.
	<b>DELO-120</b>	14 mm	n/a	-/ 206 N	06 m/min 09 12 18 24 30 36	300 kg 140 80 35 20 13 9	2x5-pin M12x1 plug R cust.-spec. solutions var. access.
	<b>ELU-20</b>	7 mm	n/a	1 N/ 20 N	06 m/min 09 12 18	20 kg 12 7 3	1 x 4-pin M12x1 plug KI cust.-spec. solutions var. access.
	<b>ELU-30</b>	7 mm	n/a	1,2 N/ 35 N	06 m/min 09 12 18	30 kg 15 9 4	1 x 4-pin M12x1 plug KI cust.-spec. solutions var. access.
	<b>DELW</b> Rotary Switch	n/a	n/a	n/a	n/a	n/a	2x5-pin M12x1 plug cust.-spec. solutions var. access.

KI tilt stop  
 KU plastic stop  
 S steel stop

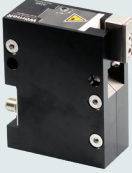
R with spring reset  
 F fast

\* All specifications given for a  
 coefficient of friction of  
 $\mu = 0.07$

## Electric damped stoppers

			<u>Basic product</u>	Lowering stroke	Damping stroke	min./max. propelling	Scope of application*		<u>Variants</u>
						at	Weight		
			<b>ELD-40</b>	7,5 mm	10 mm	0,4 N/ 45 N	06 m/min 09 12 18 24 30 36	0,25 - 40 kg 0,25 - 30 0,25 - 20 0,25 - 11 0,25 - 10 0,25 - 8 0,25 - 5	2x5-pin M12x1 plug KU cust.-spec. solutions var. access.
			<b>ELD-70</b>	8 mm	13 mm	1,4 N/ 90 N	06 m/min 09 12 18 24 30 36	2 - 70 kg 2 - 45 2 - 40 2 - 29 2 - 15 2 - 10 2 - 7	2x5-pin M12x1 plug F KU cust.-spec. solutions var. access.
			<b>ELD-140</b>	8 mm	15 mm	1,5 N/ 90 N	06 m/min 09 12 18 24 30 36	2,5 - 140 kg 2,5 - 120 2,5 - 75 2,5 - 45 2,5 - 28 2,5 - 17 2,5 - 12	2x5-pin M12x1 plug S KI/KU cust.-spec. solutions var. access.
			<b>ELD-195</b>	8 mm	20 mm	2,5 N/ 200 N	06 m/min 09 12 18 24 30 36	3,5 - 195 kg 3,5 - 170 3,5 - 150 3,5 - 80 3,5 - 50 3,5 - 35 3,5 - 25	2x5-pin M12x1 plug F KU cust.-spec. solutions var. access.
			<b>ELD-430</b>	11 mm	25 mm	3,5 N/ 420 N	06 m/min 09 12 18 24 30 36	5 - 430 kg 5 - 340 5 - 280 5 - 180 5 - 120 5 - 90 5 - 50	2x5-pin M12x1 plug KU/KI cust.-spec. solutions var. access.

# Electric damped stoppers

EL	Basic product	Lowering stroke	Damping stroke	min./max. propelling	Scope of application*		Variants
					at	Weight	
	<b>ELD-660</b>	11 mm	20 mm	5 N/ 450 N	06 m/min 09 12 18 24 30 36	660 kg 600 450 250 130 90 60	2x5-pin M12x1 plug S KI/KU cust.-spec. solutions var. access.
	<b>ELD-1200</b>	20 mm	25 mm	65 N/ 750 N	m/min 06 09 12 18	kg 1350** 1350** 1200** 700**	3x5-pin M12x1 plug, cust.-spec. solutions var. access.
	<b>DEL-235</b>	9.3 mm	16.1 mm	25 N/ 419 N	06 m/min 09 12 18 24 30	250 kg** 190** 180** 135** 110** 55**	RC cust.-spec. solutions var. access.
	<b>DEL-400</b>	9,3 mm	16.1 mm	25 N/ 419 N	06 m/min 09 12 18 24 30	400 kg** 340** 330** 255** 190** 150**	RC cust.-spec. solutions var. access.
	<b>DEL-630</b>	8 mm	16 mm	32 N/ 250 N	06 m/min 09 12 18 24 30	45 - 650 kg** 45 - 610** 45 - 450** 45 - 300** 45 - 190** 45 - 140**	cust.-spec. solutions var. access.

KI tilt stop  
 KU plastic stop  
 S steel stop

RC manual remote control  
 HS high speed

\* All specifications given for a coefficient of friction of  $\mu = 0.07$

\*\* Exceptionally, these values apply at a coefficient of friction of  $\mu = 0.02$

	<u>Basic product</u>	Lowering stroke	Damping stroke	min./max. propelling	Scope of application*		<u>Variants</u>
					at	Weight	
	<b>DEL-650</b>	9.3 mm	16.1 mm	30 N/ 419 N	06 m/min 09 12 18 24 30	650 kg** 630** 470** 350** 250** 200**	RC cust.-spec. solutions var. access.
	<b>DEL-800</b>	9.3 mm	20.2 mm	50 N/ 419 N	06 m/min 09 12 18 24 30	820 kg** 790** 760** 640** 520** 340**	RC cust.-spec. solutions var. access.
	<b>DEL-1100</b>	9.3 mm	20.2 mm	65 N/ 419 N	06 m/min 09 12 18 24	1100 kg** 1000** 850** 750** 500**	RC cust.-spec. solutions var. access.
	<b>DEL-1800</b>	9,3 mm	20,2 mm	100 N/ 419 N	06 m/min 09 12 16 18	1800 kg** 1700** 1550** 1000** 800**	RC cust.-spec. solutions var. access.
	<b>DEL-350-S2</b>	8 mm	25 mm	80 N/ 200 N	06 m/min 09 12	880 kg** 540** 370**	HS cust.-spec. solutions var. access.

# Pneumatic damped stoppers for roller systems

## ■ electrically damped

	<i>Basic product</i>	<i>Lowering stroke</i>	<i>Damping stroke</i>	<i>min./max. propelling</i>	<i>Scope of application*</i>		<i>Variants</i>
					at	Weight	
	<b>DBSR-30</b>	8 mm	5.8 mm	3,5 N/ 21 N	06 m/min 09 12 18	5-30 kg 5-25 5-12 5- 8	EW/DW cust.-spec. solutions var. access.
	<b>DBSR-270</b>	15 mm	17 mm	10,3 N/ 185 N	06 m/min 09 12 18 24 30 36	15-270 kg 15-230 15-150 15- 60 15- 30 15- 25 15- 20	EW/DW S cust.-spec. solutions var. access.
	<b>DBSR-400</b>	15 mm 25 mm	22 mm	10,3 N/ 275 N	06 m/min 09 12 18 24 30 36	15-400 kg 15-360 15-280 15-130 15- 90 15- 60 15- 40	EW/DW cust.-spec. solutions var. access.
	<b>DBSR-550</b>	15 mm 25 mm**	28 mm	10,3 N/ 850 N	06 m/min 09 12 18 24 30	18-550 kg 18-470 18-350 18-190 18-120 18- 85	EW cust.-spec. solutions var. access.
	<b>DBSR-700</b>	15 mm	36,7 mm	10 N/ 850 N	06 m/min 09 12 18 24 30	25-700 kg 25-580 25-470 25-230 25-145 25-108	EW/DW cust.-spec. solutions var. access.

EW single-acting  
 DW double-acting  
 S prepared for stop  
 position sensing  
 R spring return

\* All specifications given for a  
 coefficient of friction of  $\mu = 0.07$

\*\* Version with slightly restricted  
 damping capacity



ELUR



<u>Basic product</u>	<u>Lowering stroke</u>	<u>Damping stroke</u>	<u>min./max. propelling</u>	<u>Scope of application*</u>		<u>Variants</u>
				at	Weight	
<b>DBSR-1000</b>	15 mm	21 mm	41,3 N/ 618 N	09 m/min 12 18 24 30	60-900 kg 60-750 60-550 60-250 60-180	EW/DW cust.-spec. solutions var. access.
<b>ELUR-65</b>	10 mm	n/a	-/ 65 N	06 m/min 09 12 18	65 kg 60 55 50	2x5-pin M12x1 plug, R cust.-spec. solutions var. access.



### Custom-built:

#### DBSR-400-15-EW-004

The unit possesses an integrated anti-bounce stop designed to keep the pallet in position after the damping operation. It is also pre-assembled with pre-adjusted clamping holders designed for the installation of inductive sensors to determine the stop positions.

# Acceleration Units

	<i>Basic product</i>	<i>Lowering stroke</i>	<i>Damping stroke</i>	<i>Acceleration force</i>	<i>Variants</i>
	<b>DAU-80</b>	8 mm	21,3 mm	228 N	EW/DW cust.-spec. solutions var. access.
	<b>DAU-350</b>	9 mm	38,8 mm	570 N	EW/DW cust.-spec. solutions var. access.

EW single-acting  
DW double-acting

FS finger safety

\* All specifications given for a coefficient of friction of  $\mu = 0.07$

The acceleration unit ensures that the pallet (WT) leaves the machining station more quickly so that the next machining cycle can start earlier. As soon as the stopper has lowered, the stop of the acceleration unit moves out and accelerates the pallet. (→→)

This procedure leads to a reduction of cycle times by more than 1 second or by more than 40 %.

Acceleration units have a continuously adjustable extension speed and thus cover a wide range of applications.

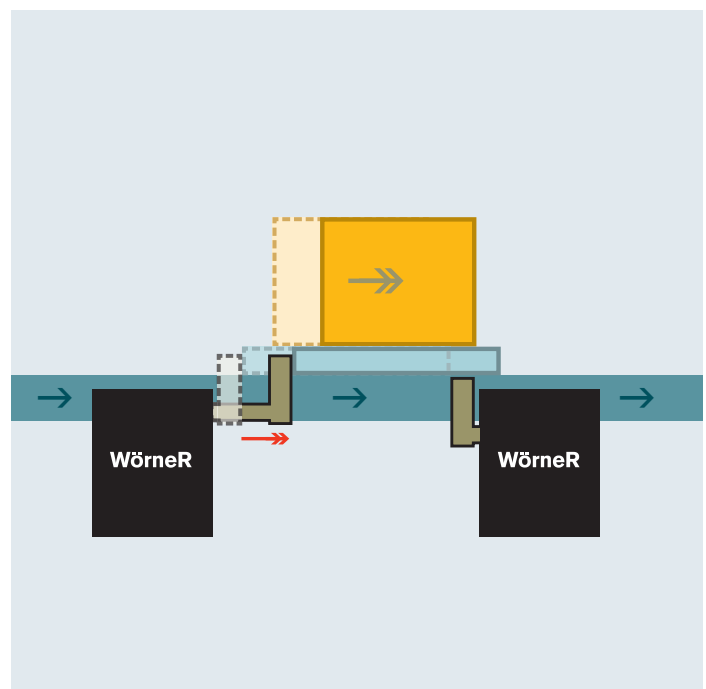



## Displacement Stops

	<u>Basic product</u>	Lowering stroke	Damping stroke	max. propelling force	Scope of application*		<u>Variants</u>
					at	Weight	
	<b>DDS-80</b>	17mm	6,5mm	54 N	06 m/min 09 12 18 24 30 36	3,5 - 80 kg 3,5 - 70 3,5 - 50 3,5 - 40 3,5 - 27 3,5 - 17 3,5 - 12	DW FS cust.-spec. solutions var. access.
	<b>DDS-160</b>	17mm	12mm	109N	06 m/min 09 12 18 24 30 36	3,5 - 160 kg 3,5 - 140 3,5 - 100 3,5 - 90 3,5 - 55 3,5 - 35 3,5 - 25	DW FS cust.-spec. solutions var. access.
	<b>DDU-100</b>	17mm	n/a	500 N	06 m/min 09 12 18 24 30 36	100 kg 90 70 60 50 28 12	DW FS cust.-spec. solutions var. access.

Displacement stops are integrated at a transverse section that connects more than two longitudinal sections.

They take over transport control at line crossings and stops pallets (WT) e.g. on lifting transverse units. Thus the pallets (WT) can be transferred from a transverse to a longitudinal section. The shifting stop can perform different functions:



**Function 1** „Stop workpiece carrier“: This function is used when the workpiece carrier is to be transferred from a longitudinal section to the transverse section.

**Function 2** „Continue workpiece carrier“: This function is used if the workpiece carrier is to continue the cross transport at the line intersection.

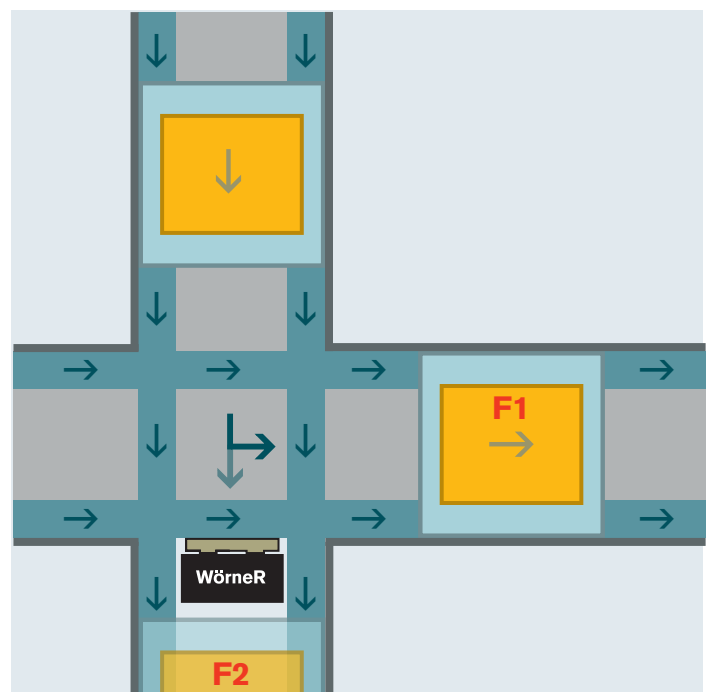
- Workpiece
- Pallet (for workpiece)
- Conveyor system (e.g. belt, chain, roller conveyor)



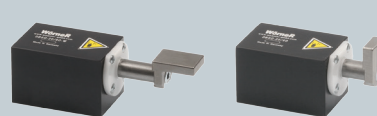

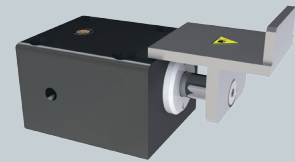
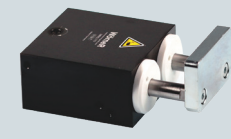

# Pneumatic/ electric angle dampers

	<u>Basic product</u>	Lowering stroke	Damping stroke	max. propelling force	Scope of application*		<u>Variants</u>
					at	Weight	
	<b>DBSQ-15</b>	n/a	7 mm	n/a	06 m/min 09 12 18 24 30 36	0.25-15 kg 0.25-10 0.25- 9 0.25- 7 0.25- 6 0.25- 4 0.25- 3	H/K W/G cust.-spec. solutions var. access.
	<b>DBSQ-20/60</b>	n/a	21.5 mm	n/a	06 m/min 09 12 18 24 30 36	1-60 kg 1-40 1-35 1-30 1-24 1-18 1-10	H/K W/KU/KA cust.-spec. solutions var. access.
	<b>DBSQ-65</b>	n/a	23 mm	n/a	06 m/min 09 12 18 24 30 36	1 - 65 kg 1 - 43 1 - 37 1 - 32 1 - 25 1 - 19 1 - 11	W cust.-spec. solutions var. access.
	<b>DBSQ-150-T4</b>	n/a	24 mm	n/a	06 m/min 09 12 18 24 30 36	5-150 kg 5-100 5-100 5- 90 5- 55 5- 35 5- 25	H/K cust.-spec. solutions var. access.
	<b>DBSQ-170</b>	n/a	29 mm	n/a	06 m/min 09 12 18 24 30 36	5-220 kg 5-190 5-160 5-150 5- 90 5- 50 5- 40	H/K cust.-spec. solutions var. access.

H heat-resistant  
K cold-resistant

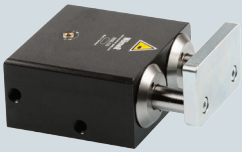
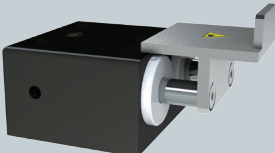
KU plastic stop  
KA plastic stop  
antistatic  
W angle stop  
G straight stop

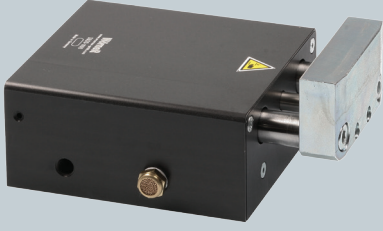
\* All specifications given for a coefficient of friction of  $\mu = 0.07$

	<u>Basic product</u>	Lowering stroke	Damping stroke	max. propelling force	Scope of application*		<u>Variants</u>
					at	Weight	
	<b>DBSQ-270</b>	n/a	24 mm	n/a	06 m/min 09 12 18 24 30 36	10-270 kg 10-220 10-200 10-180 10-110 10- 70 10- 50	H/K cust.-spec. solutions var. access.
	<b>DBSQ-300</b>	n/a	24 mm	n/a	06 m/min 09 12 18 24 30 36	10-300 kg 10-270 10-250 10-225 10-140 10- 95 10- 70	H/K cust.-spec. solutions var. access.
	<b>DBSQ-400</b>	n/a	23 mm	n/a	06 m/min 09 12 18 24 30 36	7-400 kg 7-280 7-240 7-140 7-100 7- 60 7- 40	H/K cust.-spec. solutions var. access.
	<b>DBSQ-1100</b>	n/a	21 mm	n/a	09 m/min 12 18 24 30	40-1100 kg 40-1000 40- 800 40- 450 40- 280	H/K cust.-spec. solutions var. access.
	<b>ELDQ-300</b>	n/a	14,7 mm	n/a	06 m/min 09 12 18 24 30 36	10 - 300 kg 10 - 250 10 - 150 10 - 80 10 - 40 10 - 35 10 - 30	W cust.-spec. solutions var. access.

**Custom-built:**

**3842545128**

This unit is equipped with a special stop.

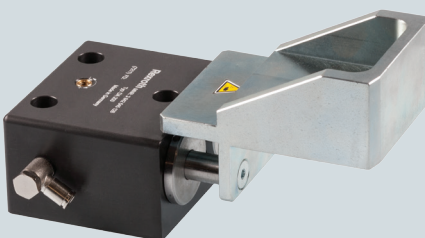

# Index cylinders



**Basic product**

Stroke

Force

max. lateral force

**Variants**

**DI-490**

31 mm

490 N

170 N

H  
I/E  
cust.-spec.  
solutions  
var. access.



**DIA-495**

31 mm

495 N

170 N

H  
I/E  
U  
cust.-spec.  
solutions  
var. access.



**DI-1050**

31,5 mm

1050 N

170 N

H  
I/E  
cust.-spec.  
solutions  
var. access.



**DI-2200-25-001**

25 mm

2200 N

240 N

Special  
variant

## Custom-built:

### DI-1050-15-007

This unit was designed as a round construction in contrast to our usual index cylinders. It is also equipped with an integrated cover.



## Anti-bounce stops



**Basic product**

**Stroke**

**Variants**

**DR**

8 mm

cust.-spec.  
solutions  
var. access.



**DRP**

8 mm

I/E  
EA  
ST  
cust.-spec.  
solutions  
var. access.



**DRE**

9 mm

cust.-spec.  
solutions  
var. access.

H heat-resistant  
I prepared for inductive position sensor  
E prepared for electronic position sensor

U universally, can be used for all types of conveyor profiles  
EA electronic sensor at stop  
ST Stopper

### Custom-built:

#### DRP-001

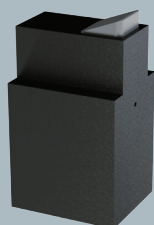

This unit possesses a different housing geometry: increased height, recesses at the side, and threaded holes at the bottom of the case to permit fastening from below.

# Accessories

## Product-specific accessories

We offer an extensive range of accessories to accompany our products. For details, please refer to the relevant data sheets.

By way of example, the accessories illustrated here are for the pneumatically driven, damped stopper DBS-20/60:

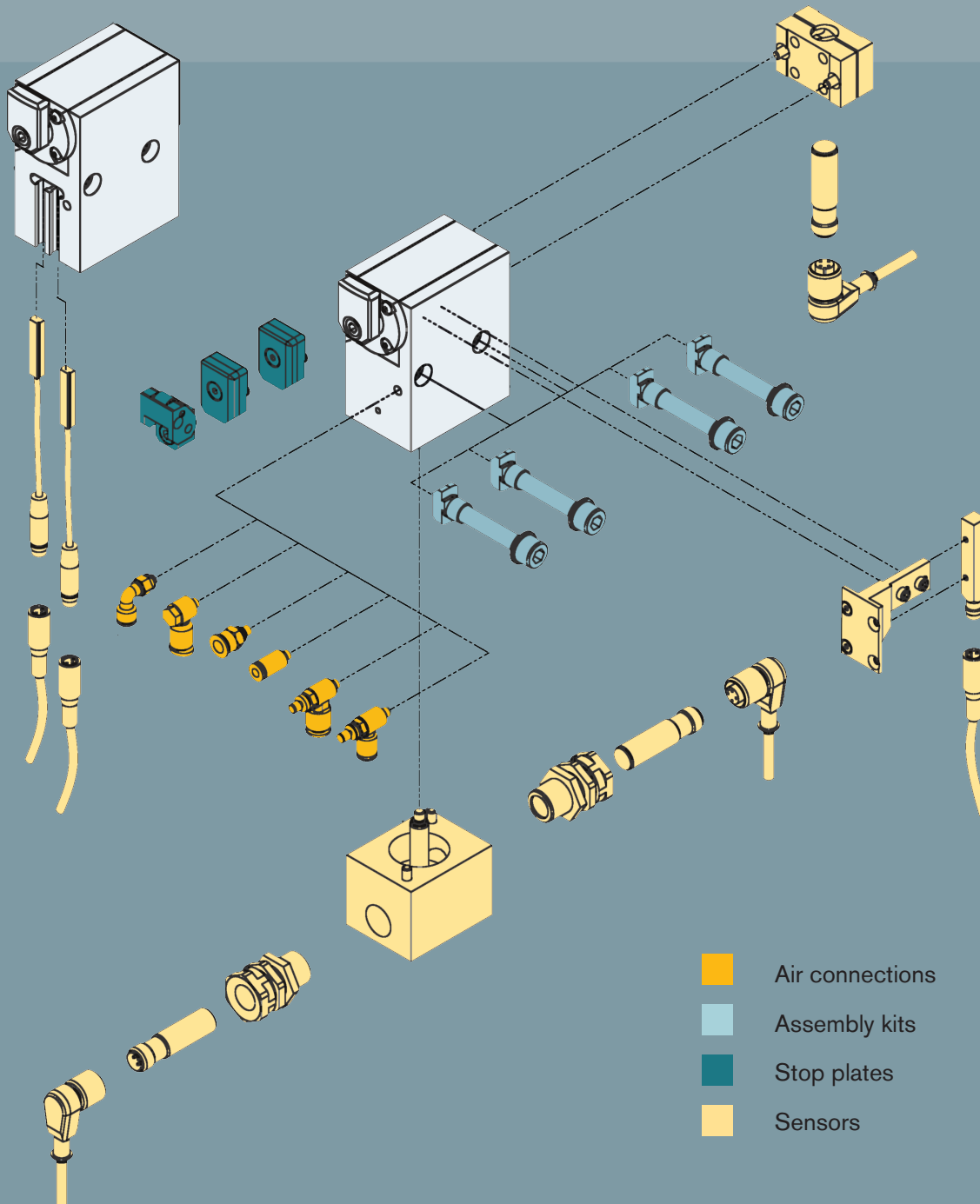

Product-independent accessories	Basic product	Variants
Position sensor for pallet	DP	AU / AS cust.-spec. solutions
Sensor bracket	DSA	H/K cust.-spec. solutions

- H heat-resistant
- K cold-resistant
- AU bottom-mounted sensor
- AS side-mounted sensor

## Calculation aid

### Maximum WT weight as a function of friction coefficient and conveying speed

You want to know the max. WT weight for a different conveying speed and/or a different coefficient of friction?

Then you can easily determine the max. WT weight for your application using the calculation aid at

[www.woerner-gmbh.com/support](http://www.woerner-gmbh.com/support).

Or simply contact our service hotline directly at:

Telefon: +497116016090

E-Mail: [sales@woerner-gmbh.com](mailto:sales@woerner-gmbh.com)

# Technical explanations



## Basic function: Lowering

### Propelling force $F_R$

The propelling force  $F_R$  is the friction force between the conveyor equipment and the pallet. It is a function of the coefficient of friction  $\mu$ , the weight of the pallet  $m$  and acceleration due to gravity  $g$ :

$$F_R = \mu \cdot m \cdot g$$

If more than one pallet has been accumulated than the number of pallets  $n$  must also be considered:

$$F_R = n \cdot \mu \cdot m \cdot g$$

The coefficient of friction  $\mu$  is a function of the friction between the conveyor equipment and the pallet.

### Examples for the coefficient of friction:

- Belt/band:  $\mu = 0.2$  to  $0.3$
- Plastic modular belt:  $\mu = 0.3$  to  $0.5$
- Accumulation roller chain:  $\mu = 0.01$  to  $0.03$

### Example calculation:

- $m_{\text{workpiece}} = 5 \text{ kg}$
- $m_{\text{pallet}} = 2 \text{ kg}$
- $\mu = 0.2$
- $g = 9.81 \text{ m/s}^2$

$$F_R = (5 + 2) \text{ kg} \cdot 0.2 \cdot 9.81 \text{ m/s}^2 = \mathbf{13.7 \text{ N}}$$

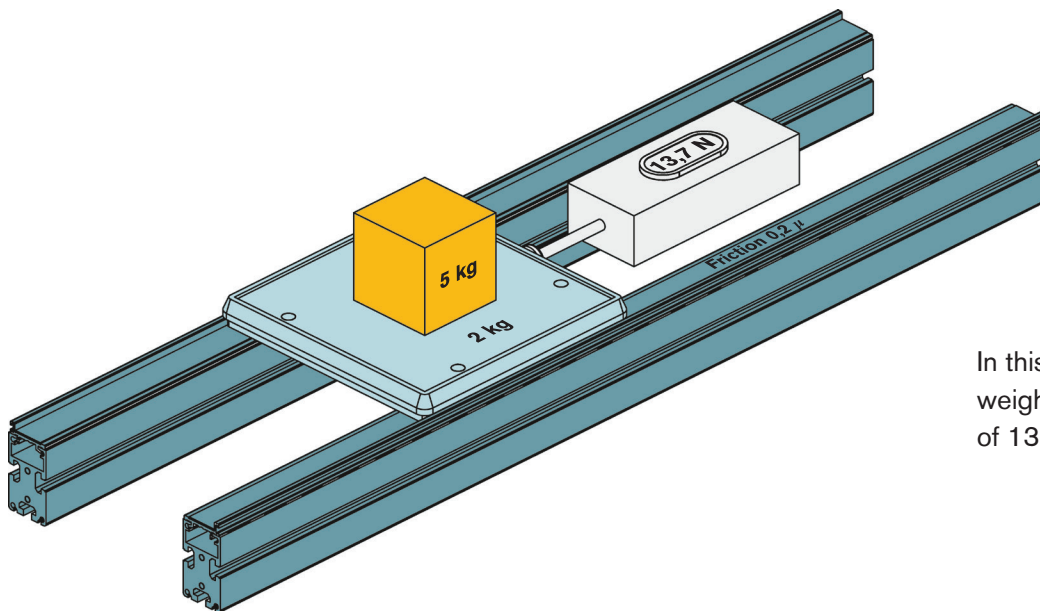

In this example, a pallet of total weight 7 kg exerts a propelling force of 13.7 N on a double belt conveyor.

The product brochure and data sheets indicate the maximum propelling force against which the stopper can reliably lower during long-term operation. The propelling force in your system must be less than the specified value.

### Example for DBS-20/60:

(Value given for coefficient of friction  $\mu = 0.07$ ):  
Maximum propelling force 41 N

Please note that other pallet weights can be reliably lowered at different coefficients of friction. Using the formula above, you can easily convert the maximum propelling force specified by us for other coefficients of friction.

We would be happy to advise you – just contact us!



## Basic function: Stopping

### Deceleration force $F_v$

(by way of example for damped stopper)

The deceleration force  $F_v$  is required to slow the pallet down to a halt and dissipate the kinetic energy stored in the pallet. It consists of the damping force (at conveyor speed  $v$  and damping stroke  $s$ ) and the propelling force, which continues to have an effect even during the damping operation:

$$F_v = \frac{m \cdot v^2}{2s} + m \cdot g \cdot \mu$$

The scope of application of the various stoppers is indicated in the product brochure and data sheets. Using these tables, it is easy to determine whether the intended stopper is able to damp the expected pallet weight at your required conveyor speed.

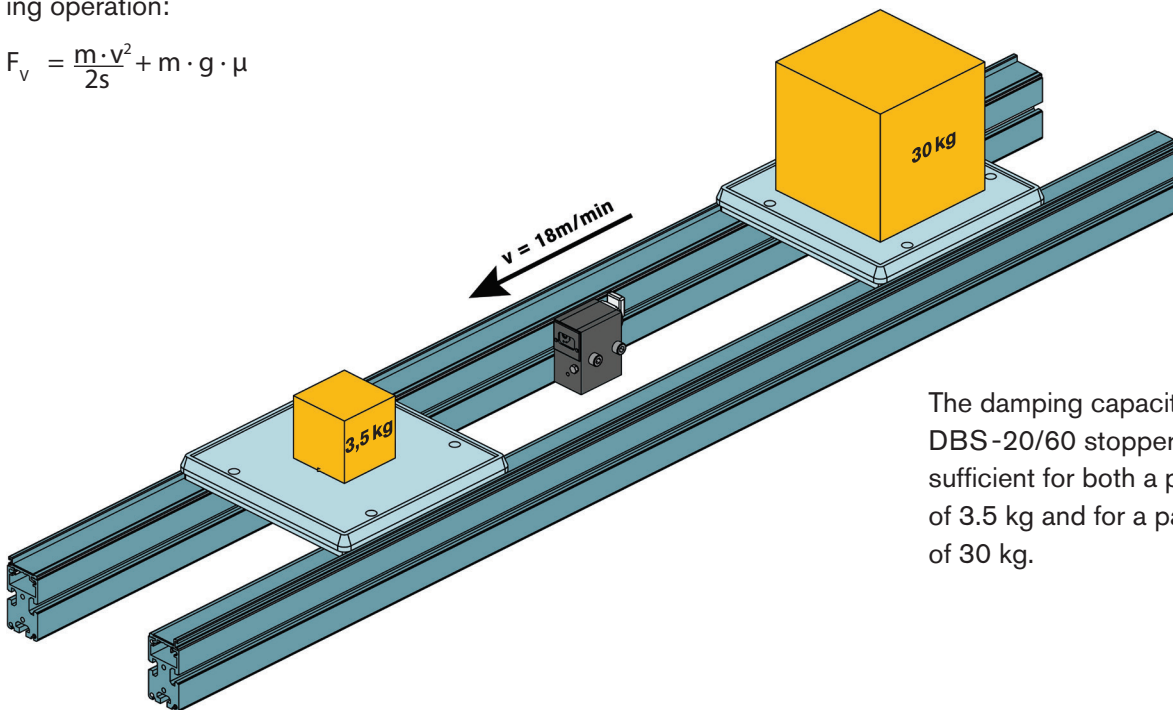

The damping capacity, e.g. of a DBS-20/60 stopper at 18m/min, is sufficient for both a pallet with a weight of 3.5 kg and for a pallet with a weight of 30 kg.

### Example for DBS-20/60

(Values given for coefficient of friction  $\mu = 0.07$ ):

#### Conveyor speed

6 m/min  
9 m/min  
12 m/min  
18 m/min  
24 m/min  
30 m/min  
36 m/min

#### Pallet weight

3.5 - 60 kg  
3.5 - 40 kg  
3.5 - 35 kg  
3.5 - 30 kg  
3.5 - 24 kg  
3.5 - 18 kg  
3.5 - 10 kg

Please note that other combinations of the conveyor speed and pallet weight parameters are possible, or may indeed be required, at different coefficients of friction. This is true, in particular, when the propelling force accounts for a high proportion of the deceleration force, i.e. in systems with high levels of friction.

You can obtain an initial approximation of these values using the formula above.

We would be happy to advise you – just contact us!

# Overview of the Wörner product system

**Product portfolio**

**Damping, stopping and positioning modules for automation technology**

**Product families**

**Stoppers**

**Angle dampers**

**Index cylinders**

**Anti-bounce stops**

**Product groups**

undamped  
pneumatic

damped  
pneumatic

undamped  
electric

damped  
electric

damped  
for roller  
systems

Accellera-  
tion Units

Displace-  
ment Stops

**Basic products<sup>1</sup>**

by scope of application, e.g. D0-400, DBS-20/60, ELU-30-KI, DEL-60, DBSR-550

**Product variants<sup>2</sup>**

e.g. in terms of lowering stroke, operating principle, stop, sensors, etc.

<sup>1</sup> The basic products differ in their scope of application, primarily in terms of the maximum pallet weight that can be stopped.

<sup>2</sup> The product variants – i.e. the products that can be ordered – are determined by selecting the required technical characteristics, for example in terms of lowering stroke, function, temperature range or stop design.

## Order code

You can identify the product variant that is right for your application by consulting the relevant basic product data sheet.

You can choose between the variants defined there, for example on the basis of the lowering stroke, function, temperature range or stop design.

We would be delighted to assist you in choosing your product variant or by developing a custom product tailor-made for your application.

The example opposite illustrates the composition of the order code for a pneumatically driven, damped stopper of type DBS-20/60.

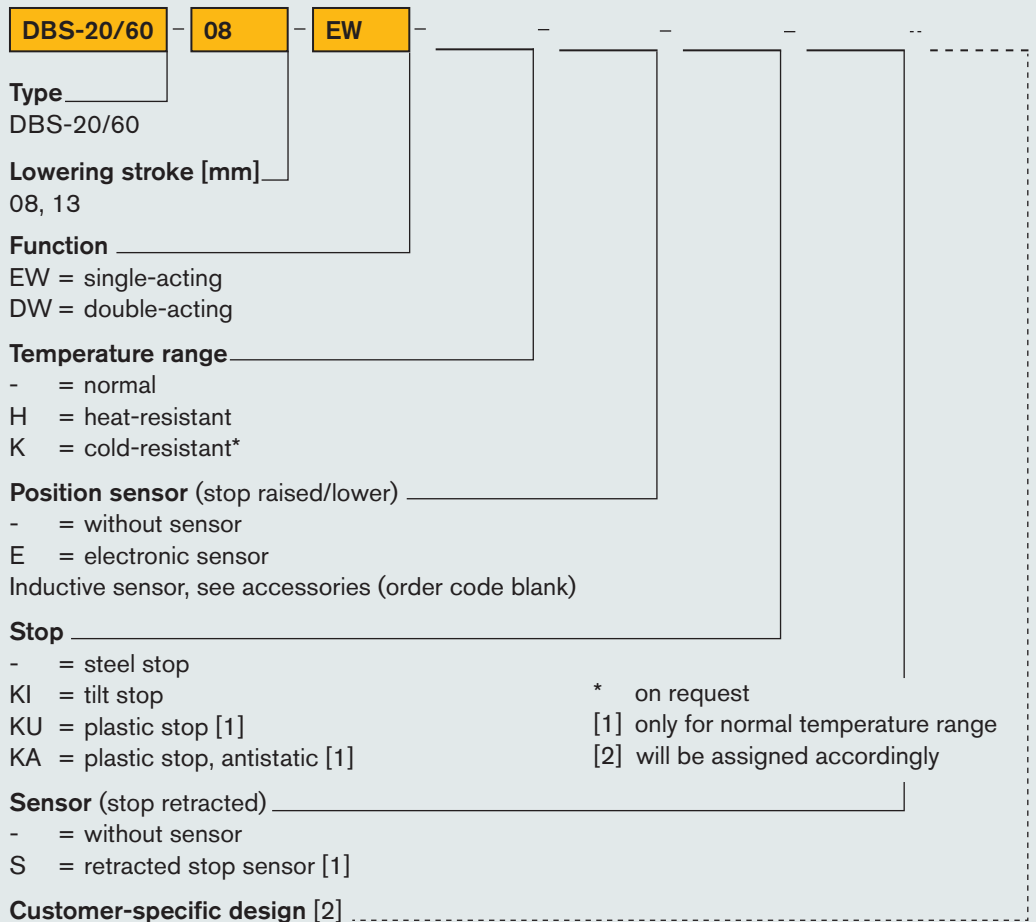

## Glossary

### **Air consumption**

A unit's compressed air consumption expressed in litres per work cycle, usually at a working pressure of 6 bar.

### **Angle damper**

For stopping with change of direction. Preferred solution for changes of direction during the conveying of shock-sensitive or fragile parts.

### **Anti-bounce stop**

For preventing rebound. Holds the pallet loaded with individual parts in position with absolute precision to prevent any rebound. Used in particular in combination with undamped stoppers.

### **Basic product**

Standard products that are differentiated according to area of application (essentially according to the maximum pallet mass to be stopped) and serve as the basis for individual product variants.

### **Coefficient of friction**

Designates the friction between the conveyor equipment and pallet. Important for the design of the stopping point because both the damping and the lowering capacity depend on the friction.

### **Conveyor speed**

Speed at which the pallet is transported.

### **Damping stroke**

Distance travelled by the stop when decelerating the pallet. The length of the damping stroke is important for the stopper's damping capacity.

### **Deceleration force**

Required to slow the pallet down to a halt and dissipate the kinetic energy stored in the pallet. It consists of the damping force and the propelling force, which continues to have an effect even during the damping operation.

### **Electronic sensor**

Electronic, non-contact sensor system for the detection of certain stop positions.

### **Friction**

Force required to set a stationary body in motion or to continue to move a moving body in a constant way. Is a function of the coefficient of friction and weight of the body.

### **Index cylinder**

For raising and positioning. Guarantees precise positioning and vertical lifting of the pallet and is ideal for rapid positioning tasks. The workpiece can be processed without vibration.

### **Inductive sensor**

Inductive, non-contact sensor system for the detection of certain stop positions.

### **Lowering stroke**

Distance travelled by the stop to clear and lock (lower or raise) the pallet.

### **Operating pressure**

Working pressure of the pneumatic system. Specifications in data sheets (for the lowering force, for example) usually refer to a operating pressure of 6 bar.

### **Order code**

The order code reflects the composition of a product variant and uniquely identifies this. It is possible to order directly from Wörner using this code.

### **Pallet weight**

Weight of the pallet and/or the workpiece.

### **Position sensor**

Accessory available for many stopper models. Can be used to determine the position of the stop. For full functionality, further accessories are required (proximity switch, for example).

### **Product variant**

Variant derived from a basic product (for example in terms of lowering stroke, function, temperature range or stop design). The name of the product variant corresponds to the order code that can be used to order the unit from Wörner.

### **Propelling force**

Friction force between the conveyor equipment and pallet. Is a function of the coefficient of friction, pallet weight and acceleration due to gravity.

### **Scope of application**

Identifies a stopper's damping capacity. Table specifying the maximum pallet weight that can be stopped at different conveyor speeds.

### **Separating stop, damped**

For stopping and clearing pallets. For shock-sensitive, fragile parts. Pallets are gently decelerated as they arrive so that workpieces reach their final position without rebound. The forces transferred to the conveyor system are considerably reduced.

### **Separating stop, undamped**

For stopping and clearing pallets. Tough, economical basic design. Suitable for use wherever one or more pallets are to be accumulated at a defined position.

### **Single-acting**

Lowering is a pneumatically or electrically driven movement. By contrast, the stop is raised into the locking position by spring force. Benefits: Easier to control because, for example, only one pneumatic connection is needed. When no compressed air is supplied, the stopper always moves to the locked position (safety feature).

### **Stop**

Component on which the WT hits. Available in different versions and dimensions (plastic, steel or tilt stop). Material pairing between WT and stop is important for the achievable lowering force.

## Wörner worldwide

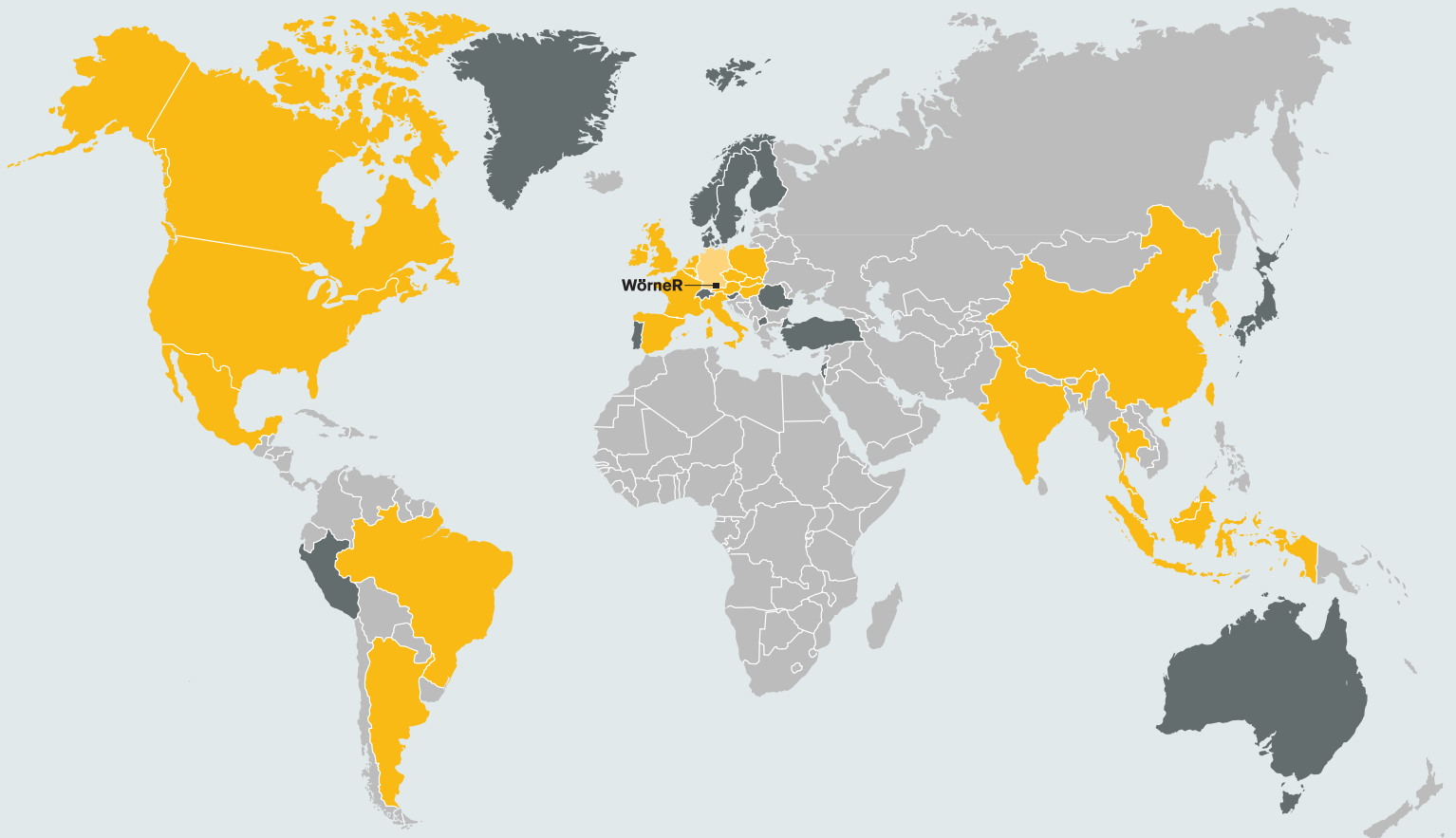

- Countries with regional sales offices or partners
- Countries with well-established customer relationships

Contact details of our international sales partners are available on our website: [www.woerner-gmbh.com](http://www.woerner-gmbh.com)

## Contact us for more

We are committed to exceptional service and support.

If you should have any questions related to products, orders or shipments, or if you should require personal advice, simply contact our headquarter in Denkendorf. We will put you in touch with a representative who understands your needs.

### Wörner Automatisierungstechnik GmbH

Rechbergstraße 50  
73770 Denkendorf  
Germany

Tel. +49 711 601 609-0  
Fax +49 711 601 609-10

[sales@woerner-gmbh.com](mailto:sales@woerner-gmbh.com)  
[www.woerner-gmbh.com](http://www.woerner-gmbh.com)