



# SAFE AIR ENTRY ASSEMBLIES WITH DM SERIES C VALVES

## PRODUCT CATALOG



# Safe Air Entry Assemblies with DM<sup>1</sup> & DM<sup>2</sup>® Series C

## Product Overview



Air entry assembly for Pneumatic Control and Air Dump/Release applications.

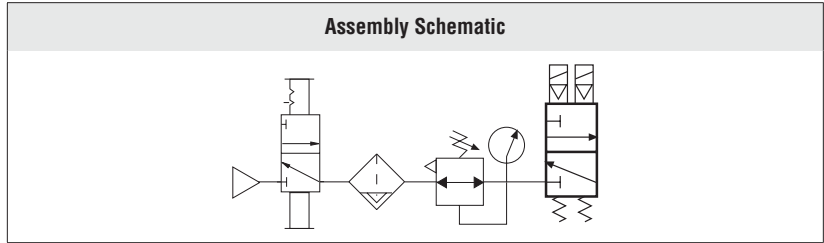

Air entry system via a manual Lockout L-O-X® valve, air preparation FRL combinations, and an DM<sup>1</sup> or DM<sup>2</sup>® Series C Safe Exhaust double valve. ROSS systems have the same quality that you have come to expect from ROSS components. Units are fully configurable, tested, and ready for quick and easy installation at the job site.

- Custom designs available, consult ROSS
- Explosion proof solenoid pilot available, for more information consult ROSS

### ASSEMBLY COMPONENTS & FEATURES

#### Energy Isolation Lockout L-O-X® Valve 15 Series

- 3/2 valve
- Classic or Modular L-O-X®
- Lockable only in the OFF position
- Has a full size exhaust port (equal to or larger than supply)
- Simple push/pull of the large handle provides positive direct manual operation
- Fluorocarbon slipper seals for easy shifting, even after long periods of inactivity
- Integrated sensing port for pressure verification or visual indicator
- High flow, clog resistant; silencers included

#### Filter and Regulator Integrated Filter/Regulator, and Lubricator Filter, Regulator, and Lubricator MD3™, MD4™, and High-Capacity Series

- Filter, Integrated Filter/Regulator, and Lubricator with metal bowls
- 5-micron filter element
- Automatic drain
- Analog gauge

#### Control Reliable Safe Exhaust Double Valve DM<sup>1</sup> or DM<sup>2</sup>® Series C

- 3/2 valve
- Self-contained dynamic monitoring system requires no further valve monitoring controls
- Status indicator (mechanical pressure switch) for valve condition (ready-to-run) feedback
- DM<sup>1</sup> Series C
  - Automatic reset
- DM<sup>2</sup> Series C
  - Dynamic memory of abnormal function prevents unintentional reset with removal and or reapplication of air or electricity
  - Electrical solenoid reset

#### Mounting

Mounting plate assembly design.

#### SISTEMA Library

Available for download at [rosscontrols.com](http://rosscontrols.com).

### DM<sup>1</sup> & DM<sup>2</sup>® SERIES C VALVE PRODUCT CREDENTIALS

Safety Category	DGVU (German Social Accident Insurance)	Declaration of Conformity			ISO Standard	CSA Certificate of Compliance	CRN Certification
		CE	UKCA	EAC			
					ISO 13849-1:2015		Available for appropriately tested valves

**NOTE:** Per specifications and regulations, lockout L-O-X® products are defined as energy isolation devices, NOT AS EMERGENCY STOP DEVICES. These valve assemblies are not designed for controlling clutch/brake mechanisms on mechanical power presses.

### MODEL NUMBER CONFIGURATOR with Classic Lockout L-O-X® Valve

RC
4
08
-
06
W

**Series**

**Thread**

G	D
NPT (Leave Blank)	

**Safe Exhaust Valve**

DM <sup>1</sup> Series C	3
DM <sup>2®</sup> Series C	4

**Port Size**

Safe Exhaust Valve	Port Size			
	In	Out	Exhaust	
DM <sup>1</sup> C and DM <sup>2®</sup> C	1/2	1/2	1	08
	3/4	3/4	1	12
	1	1	1	16
DM <sup>2®</sup> C only	1	1	1-1/2	16HF
	1-1/2	2	2-1/2	32

**Lockout Valve\***

Classic L-O-X®

\* Silencer Included.

**Other Options\***

Connector	Description	
DIN EN 175301-803 Form A	Solenoids	Connector not included
	Solenoid Reset**	
	Mechanical Pressure Switch	DIN EN Connector included
(Leave Blank)		
M12 (24 V DC only)	Solenoids	Adapter DIN EN to M12 Connector included
	Solenoid Reset**	
	Mechanical Pressure Switch	005

\* See options for connectors or wiring kits.  
\*\* DM<sup>2®</sup> Series C valves only.

**Filter, Regulator, Lubricator\***

Filter, Regulator, Lubricator*	Port Size	
Filter and Regulator (Leave Blank)	1/2 to 1-1/2	
Integrated Filter/Regulator and Lubricator	1/2 & 3/4	L
Filter, Regulator and Lubricator	1 & 1-1/2	

\* MD4™ Series models for 1/2 & 3/4 port size.  
High-Capacity Series models for 1 & 1-1/2 port size.

Current	Voltage*	
DC	24 V	W
AC	110 V, 50 Hz	Z
	120 V, 50/60 Hz	
	230 V, 50/60 Hz	C**

\* For other voltages consult ROSS.  
\*\* 230 V AC not available in the U.S. (OSHA regulations limit press control voltage to no more than 120 V AC).

### MODEL NUMBER CONFIGURATOR with Modular Lockout L-O-X® Valve

D
RC
3
04
-
09
W

**Series**

**Thread**

G	D
NPT (Leave Blank)	

**Safe Exhaust Valve**

DM <sup>1</sup> Series C	3
DM <sup>2®</sup> Series C	4

**Port Size**

In	Out	Exhaust	
1/4	1/4	3/4	04
3/8	3/8	3/4	06

**Filter, Regulator, Lubricator**

Integrated Filter/Regulator (Leave Blank)	
Filter, Regulator, and Lubricator	L

\* MD3™ Series models.

**Lockout Valve\***

Modular L-O-X®

\* Silencer Included.

**Other Options\***

Connector	Description	
DIN EN 175301-803 Form A	Solenoids	Connector not included
	Solenoid Reset**	
	Mechanical Pressure Switch	DIN EN Connector included
(Leave Blank)		
M12 (24 V DC only)	Solenoids	Adapter DIN EN to M12 Connector included
	Solenoid Reset**	
	Mechanical Pressure Switch	005

\* See options for connectors or wiring kits.  
\*\* DM<sup>2®</sup> Series C valves only.

Current	Voltage*	
DC	24 V	W
AC	110 V, 50 Hz	Z
	120 V, 50/60 Hz	
	230 V, 50/60 Hz	C**

\* For other voltages consult ROSS.  
\*\* 230 V AC not available in the U.S. (OSHA regulations limit press control voltage to no more than 120 V AC).

# Technical Data

## FLOW

DM <sup>20</sup> & DM <sup>1</sup> Series C Valves	Port Size			Flow C <sub>v</sub>	
	1	2	3	1-2	2-3
	1/4	1/4	3/4	1.7	2.6
3/8	3/8	3/4	2.2	3.6	
1/2	1/2	1	3.0	6.5	
3/4	3/4	1	4.2	9.4	
1	1	1	4.3	9.4	
1	1	1-1/2	8.7	17	
1-1/2	2	2-1/2	20	55	

## Solenoid & Pressure Switch Pinouts

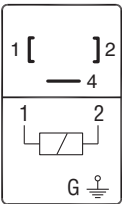
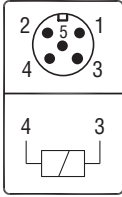
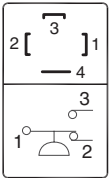
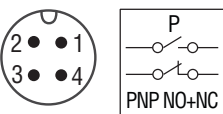
	DIN EN 175301-803 Form A	M12
<b>Solenoid</b>	 <p>1 - Positive 2 - Negative 4 - Ground</p>	 <p>3 - Positive 4 - Negative</p>
<b>Pressure Switch</b>	 <p>1 - Common 2 - Normally Closed 3 - Normally Open 4 - Ground</p>	 <p>1, 2, 3, 4 - Pin PNP - Switched Positive NO - Normally Open NC - Normally Closed</p>

DIMENSIONS							
Port Size			FRL Combination	Assembly Model Number Identification	Dimensions inches (mm)		
In	Out	Exhaust			Mounting Plate		Unit Depth
					Length	Width	
1/4	1/4	3/4	Integrated Filter/Regulator	DRC304-09*** DRC404-09***	13.00 (330.2)	13.00 (330.2)	5.50 (139.7)
			Filter, Regulator, and Lubricator	DRC304L-09*** DRC404L-09***	17.00 (431.8)	14.50 (368.3)	
3/8	3/8	3/4	Integrated Filter/Regulator	DRC306-09*** DRC406-09***	13.00 (330.2)	13.00 (330.2)	5.50 (139.7)
			Filter, Regulator, and Lubricator	DRC306L-09*** DRC406L-09***	17.00 (431.8)	14.50 (368.3)	
1/2	1/2	1	Filter and Regulator	DRC308-06*** DRC408-06***	24.00 (609.6)	17.00 (43.2)	7.50 (190.5)
			Integrated Filter/Regulator, and Lubricator	DRC308L-06*** DRC408L-06***			
3/4	3/4	1	Filter and Regulator	DRC312-06*** DRC412-06***	24.00 (609.6)	17.00 (431.8)	8.50 (215.9)
			Integrated Filter/Regulator, and Lubricator	DRC312L-06*** DRC412L-06***			
1	1	1	Filter and Regulator	DRC316-06*** DRC416-06***	27.00 (685.8)	18.00 (457.2)	9.00 (228.6)
			Filter, Regulator, and Lubricator	DRC316L-06*** DRC416L-06***	30.00 (762.0)	20.00 (508.0)	
1	1	1-1/2	Filter and Regulator	DRC316HF-06*** DRC416HF-06***	30.00 (762.0)	20.00 (508.0)	10.00 (254.0)
			Filter, Regulator, and Lubricator	DRC316HFL-06*** DRC416HFL-06***	34.00 (863.6)		
1-1/2	2	2-1/2	Filter and Regulator	DRC432-06***	32.00 (812.8)	23.00 (584.2)	12.50 (317.5)
			Filter, Regulator, and Lubricator	DRC432L-06***	37.00 (939.8)		

# Technical Data

## Models with Classic Lockout L-O-X® Valve

### ASSEMBLY COMBINATION EXAMPLES

DIMENSIONS – Inches (mm)

Port Size 1/2"

with MD4™ Filter and Regulator option

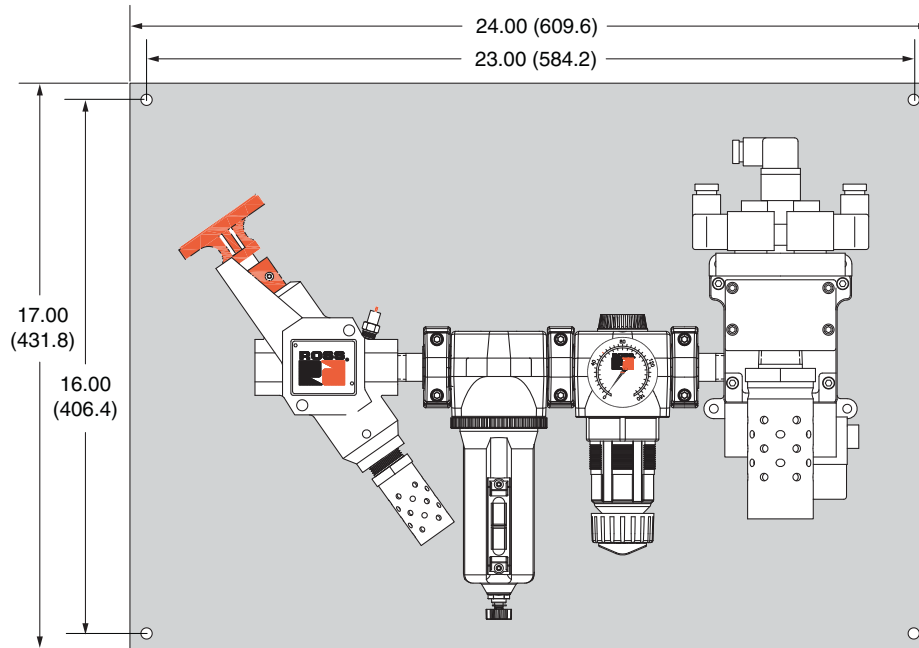

with MD4™ Integrated Filter/Regulator and Lubricator option

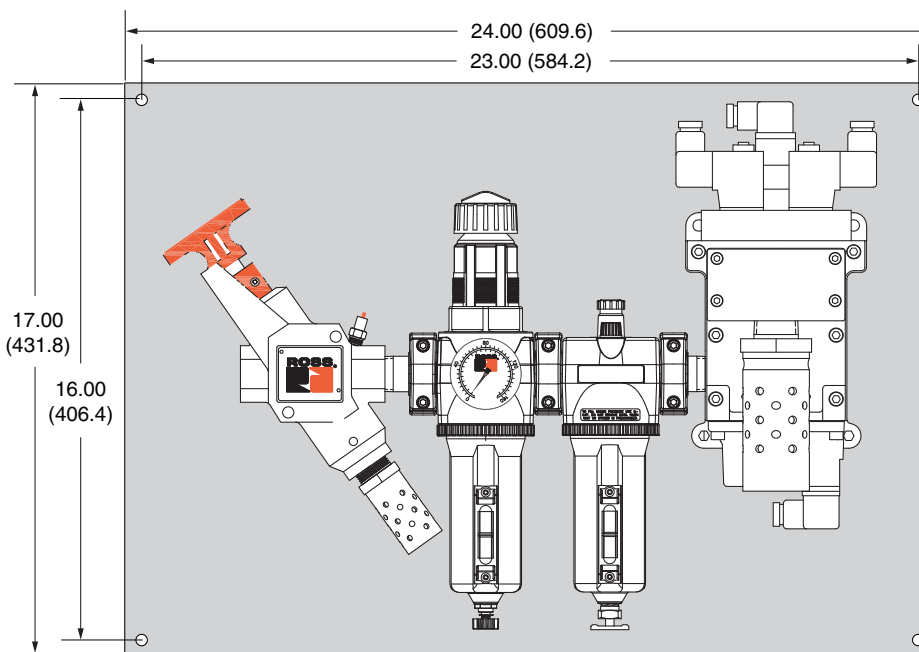

For additional information, and to assist you with piping and connectivity designs, our products are available in downloadable 2D drawings and 3D CAD models in a wide range of options including native formats, visit [www.rosscontrols.com](http://www.rosscontrols.com).

## Models with Classic Lockout L-O-X® Valve

### ASSEMBLY COMBINATION EXAMPLES

DIMENSIONS – Inches (mm)

#### Port Size 1"

##### with High-Capacity Filter and Regulator option

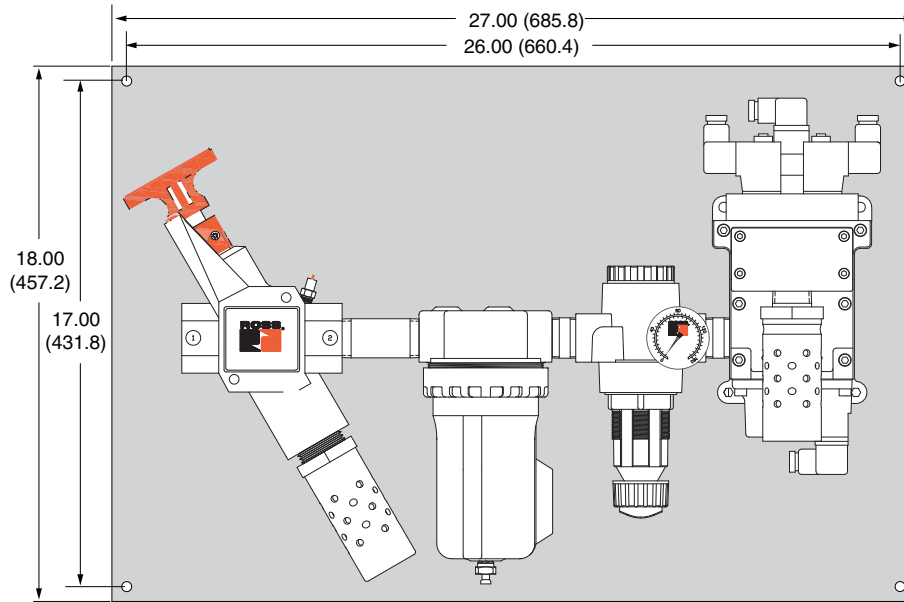

##### with High-Capacity Filter, Regulator and Lubricator option

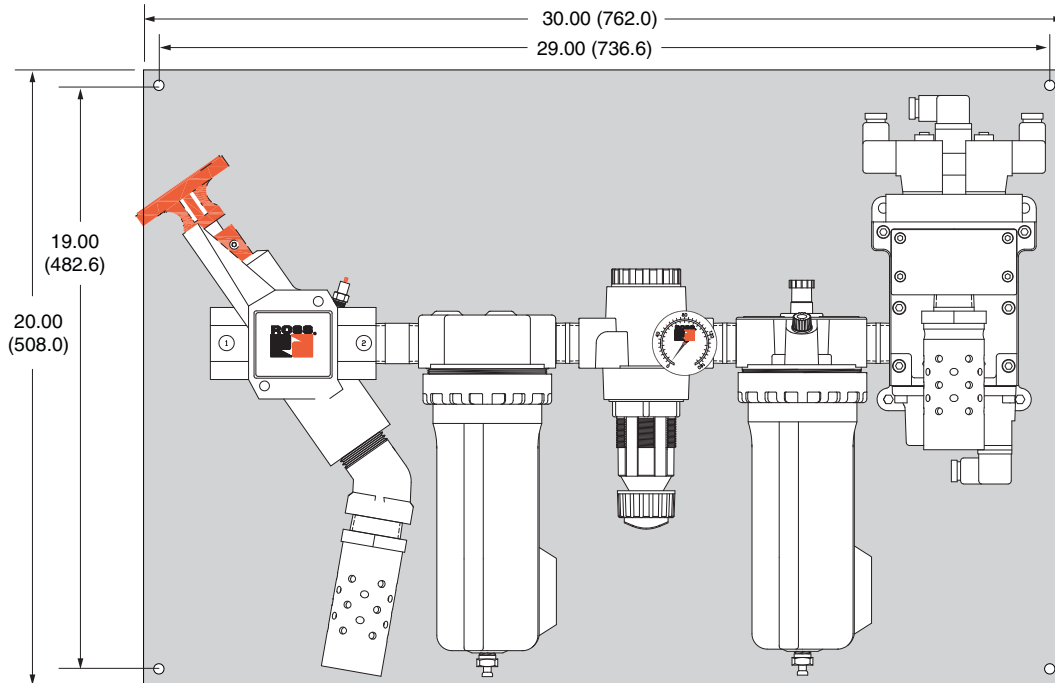

For additional information, and to assist you with piping and connectivity designs, our products are available in downloadable 2D drawings and 3D CAD models in a wide range of options including native formats, visit [www.rosscontrols.com](http://www.rosscontrols.com).

# Technical Data

## Models with Modular Lockout L-O-X® Valve

### ASSEMBLY COMBINATION EXAMPLES

DIMENSIONS – Inches (mm)

Port Size 1/4 or 3/8"

with MD3™ Integrated Filter/Regulator option

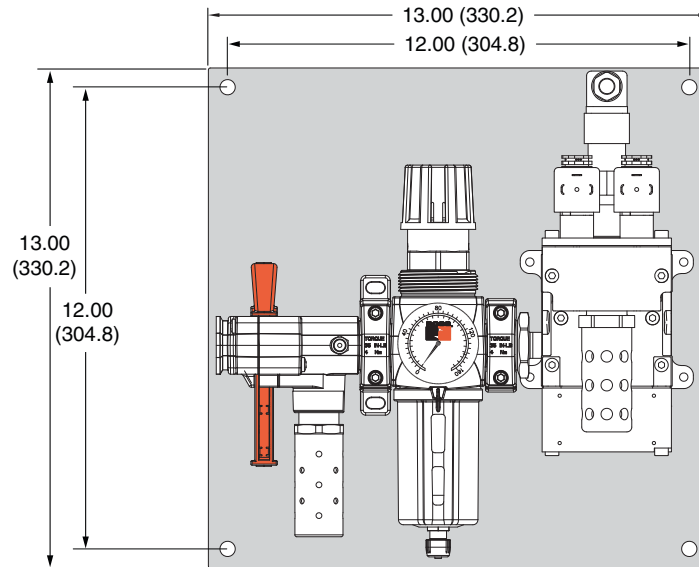

with MD3™ Integrated Filter/Regulator, Lubricator option

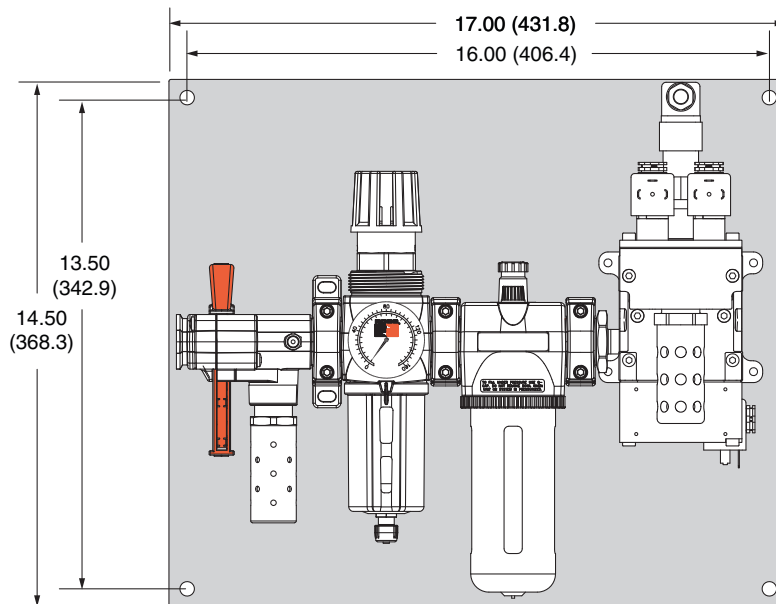

For additional information, and to assist you with piping and connectivity designs, our products are available in downloadable 2D drawings and 3D CAD models in a wide range of options including native formats, visit [www.rosscontrols.com](http://www.rosscontrols.com).



## ELECTRICAL STATUS INDICATION

Pressure Switches for Status Indicator	Indicator Type	Connector Type	Model Number	Port Thread	Factory Preset psi (bar)
	Mechanical Pressure Switch	DIN EN 175301-803 Form A	1104A30	M10x1	22 (1.5) falling
		M12	1153A30		
Solid State Pressure Sensor	M12	1335B30W	M10x1	17 (1.2) falling	

Status Indicator Assemblies	Indicator Type	Connector Type	Model Number	Factory Preset psi (bar)
	Mechanical Pressure Switch	DIN EN 175301-803 Form A	Y670B94	22 (1.5) falling
	Solid State Pressure Sensor	M12	Y766B94	17 (1.2) falling

## ENERGY RELEASE VERIFICATION

Visual Pressure Indicator	Verification Type	Indicator Type	Model Number	Port Thread
	Pneumatic	Visual Pop-up Pin	988A30	1/8 NPT

Pressure Switch	Verification Type	Connector Type	Model Number	Factory Preset psi (bar)	Port Thread
	Electrical	DIN EN 175301-803 Form A	586A86	5 (0.3) falling	1/8 NPT

Redundant Pressure Switch Assembly	Verification Type	Installation Location	Connector Type	Model Number	Factory Preset psi (bar)	Port Thread
	Electrical (Dual)	Downstream	DIN EN 175301-803 Form A	RC026-13	5 (0.3) falling	3/8 NPT

### Pinouts

Mechanical Pressure Switch		Solid State Pressure Sensor
DIN EN 175301-803 Form A	M12	M12
<p>1 - Common 2 - Normally Closed 3 - Normally Open 4 - Ground (Not Used)</p>	<p>1 - Common 2 - Normally Closed 3 - Not Used 4 - Normally Open</p>	<p>1, 2, 3, 4 - Pin PNP - Switched Positive NO - Normally Open NC - Normally Closed</p>

# Accessories

## PREWIRED ELECTRICAL CONNECTOR KITS

Pre-wired Connector Kits	Cable						Kit Number
	End 1	End 2	Length meters (feet)	Connection	Quantity Included	Cord Diameter mm	Without Light
	Connector	Cord					
for DM <sup>1</sup> Series C Valves	DIN EN 175301-803 Form A	Flying leads	5 (16.4)	Solenoid	2	6	2243H77
			10 (32.8)	Solenoid	2	6	2244H77
	M12 5-pin, Female	Flying leads	5 (16.4)	Solenoid	2	6	2245H77
			10 (32.8)	Solenoid	2	6	2246H77

Pre-wired Connector Kits for DM <sup>2</sup> ® Series C Valves	Cable						Kit Number			
	End 1	End 2	Length meters (feet)	Connection	Quantity Included	Cord Diameter mm	Without Light	Lighted Connector		
	Connector	Cord						24 V DC	120 V AC	230 V AC
	DIN EN 175301-803 Form A	Flying leads	5 (16.4)	Solenoid	3	6	2283H77	2532H77-W	2532H77-Z	2532H77-Y
Status Indicator				1						
10 (32.8)			Solenoid	3	6	2284H77	2533H77-W	2533H77-Z	2533H77-Y	
			Status Indicator	1						
M12 5-pin, Female	Flying leads	5 (16.4)	Solenoid	3	6	2288H77	-	-	-	
			Status Indicator	1						
		10 (32.8)	Solenoid	3	6	2289H77	-	-	-	
			Status Indicator	1						

### Connector Pinouts

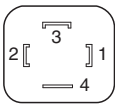
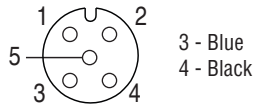
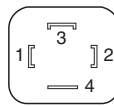
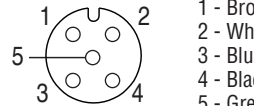
Solenoid		Status Indicator	
DIN EN 175301-803	M12	DIN EN 175301-803	M12
 <p>1 - Black 2 - Black 3 - Green/Yellow (Ground) 4 - Ground</p>	 <p>1 - Blue 2 - Black 3 - Blue 4 - Black 5 - Blue</p>	 <p>1 - Brown 2 - Grey 3 - Black 4 - Green/Yellow (Ground) 5 - Ground</p>	 <p>1 - Brown 2 - White 3 - Blue 4 - Black 5 - Grey</p>

## PREWIRED ELECTRICAL CONNECTORS

Prewired Connectors for DM <sup>1</sup> Series C Valves	Cable						Model Number			
	End 1	End 2	Connection	Quantity Included	Length meters (feet)	Cord Diameter mm	Without Light	Lighted Connector		
	Connector	Cord						24 V DC	120 V AC	230 V AC
	DIN EN 175301-803 Form A	Flying leads	Solenoid	1	2 (6.5)	6	721K77	720K77-W	720K77-Z	720K77-Y
1				10		371K77	383K77-W	383K77-Z	383K77-Y	
DIN EN 175301-803 Form A	Flying leads	Status	1	5 (16.4)	-	2247H77	-	-	-	
			1	10 (32.8)	-	2248H77	-	-	-	
M12 5-pin, Female	Flying leads	Indicator	1	5 (16.4)	-	2666H77	-	-	-	
			1	10 (32.8)	-	2667H77	-	-	-	

Prewired Connectors for DM <sup>2</sup> Series C Valves	Cable						Model Number			
	End 1	End 2	Connection	Quantity Included	Length meters (feet)	Cord Diameter mm	Without Light	Lighted Connector		
	Connector	Cord						24 V DC	120 V AC	230 V AC
	DIN EN 175301-803 Form A	Flying leads	Solenoid	1	2 (6.5)	6	721K77	720K77-W	720K77-Z	720K77-Y
1				2 (6.5)	10	371K77	383K77-W	383K77-Z	383K77-Y	
M12 5-pin, Female	Flying leads	Status Indicator	1	5 (16.4)	6	2241H77	-	-	-	
			1	10 (32.8)	6	2242H77	-	-	-	

### Connector Pinouts

Solenoid		Status Indicator	
DIN EN 175301-803	M12	DIN EN 175301-803	M12
<p>1 - Black 2 - Black 4 - Green/Yellow (Ground)</p>	<p>3 - Blue 4 - Black</p>	<p>1 - Brown 2 - Grey 3 - Black 4 - Green/Yellow (Ground)</p>	<p>1 - Brown 2 - White 3 - Blue 4 - Black 5 - Grey</p>

# Accessories

## ELECTRICAL CONNECTORS

Connectors	Connector					Model Number			
	Type	Connection	Fitting Connection	Quantity Included	Cord Diameter mm	Without Light	Lighted Connector		
							24 V DC	120 V AC	230 V AC
DIN EN 175301-803 Form A	Solenoid		Cable grip	1	8 to 10	937K87	936K87-W	936K87-Z	936K87-Y
			1/2" NPT conduit	1	-	723K77	724K77-W	724K77-Z	724K77-Y

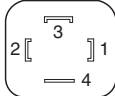
Connector Pinout	
DIN EN 175301-803	
	<p>1 - Black                  2 - Black                  4 - Green/Yellow (Ground)</p>

JUNCTION BOX OPTIONS

Wiring Kits with J-Box	J-Box			Cable			Kit Number	
	Connection Type		J-Box Quantity	Connector Type		Quantity Included		Length meters (feet)
	Control System	Solenoids / Status Indicator		End 1	End 2			
10-pin Mini	M12 (5-pin)	1	M12	DIN EN 175301-803 Form A	4	1.0 (3.3)	2249H77	
			M12	M12			4	1.0 (3.3)

10-Pin MINI Cables	Connection Type	Cable				Kit Number
		End 1	End 2	Conductors Type	Quantity Included	
J-Box to Control System	10-pin Mini	Flying leads	18-gauge wire	1	3.7 (12)	2253H77
				1	6.1 (20)	2254H77
				1	9.1 (30)	2255H77
				1	15.2 (50)	2256H77

Outlet Port Pressure Monitoring Wiring Kit	Port Splitter			Cable			Kit Number	
	Port Connectors	Number of Ports	Splitter Quantity	Connector Type		Quantity Included		Length meters (feet)
				End 1	End 2			
M12	3	1	M12	DIN EN 175301-803 Form A	1	1.0 (3.3)	2251H77	

Connectors Pinout and Wiring Diagram

J-Box Wiring

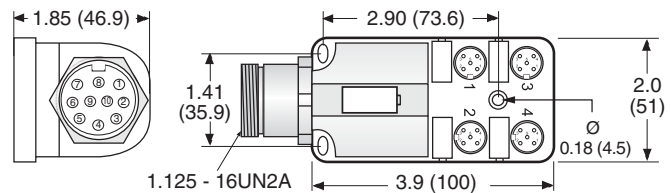
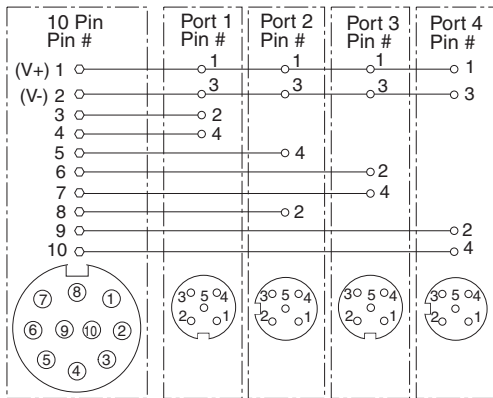

10-Pin MINI Cable

PIN #	Wire Colors	PIN #	Wire Colors
1 +24 V DC	Orange	6 -	Orange w/Black
2 Common V DC	Blue	7 Remote Reset	Red
3 -	White w/Black	8 -	Green/Yellow
4 Solenoid A	Red w/Black	9 Remote Valve Fault Light	Black
5 Solenoid B	Green w/Black	10 Remote System OK Light	White



Outlet Port Pressure Monitoring – Port Splitter

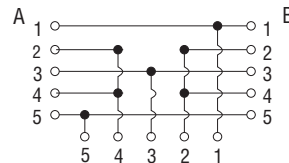
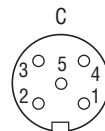
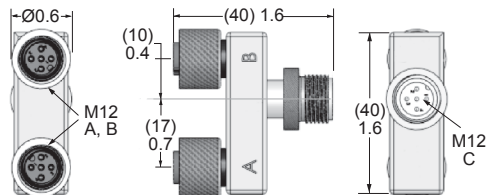

A & B Female  
C Male

# Accessories

## LOCKOUT DEVICE

Lockout Hasp	Valve Model Use	Model Number
	Manual Lockout L-O-X® Classic	356A30

## EXHAUST SILENCERS

High Flow Noise Reduction Silencer Kits	Valve Basic Size	Kit Number*		
		R/Rp Thread	NPT Thread	
	2	2328H77	2323H77	
4	2329H77	2324H77		
8	2329H77	2325H77		
12	2330H77	2326H77		
30	2331H77	2327H77		
* Kits include all plumbing required for installation.				
Reduces the Exponentially Perceived Noise (EPNdB), Impact noise reduction in the 35–40 dB range. Recommended for air exhaust applications for pressures up to 125 psig (8.6 bar). Pressure Range – 125 psig (8.6 bar) maximum.				

Valve Basic Size	Flow scfm (L/s)	Dimensions** inches (mm)				Pressure Range psig (bar)
		Width	Height (R)	Height (NPT)	Depth	
2	800 (378)	4.96 (126.1)	16.05 (407.7)	14.24 (361.7)	5.73 (145.5)	0-125 (0-8.6) maximum
4	800 (378)	4.34 (110.2)	21.40 (543.6)	19.06 (484.1)	7.27 (184.7)	
8	800 (378)	5.41 (137.4)	23.52 (597.4)	21.18 (538.0)	8.41 (213.6)	
12	2080 (982)	6.74 (117.2)	28.20 (716.3)	25.85 (656.6)	10.66 (270.8)	
30	7200 (3398)	9.85 (250.2)	41.55 (1055.4)	41.55 (1055.4)	13.47 (342.1)	
** Dimensions reflect valve with installed silencer.						

## MODULAR CONNECTION

M35 Series valves have both modular receptacles for piping and female threaded ports inside receptacles, which allows either modular connection or direct piping. Mounting accessories listed below are used for modular connection to ROSS MD Series filter-regulator units.

Mounting Brackets & Clamp for Module Connections	Options	Model Number
	Bracket, Screw, Clamp and Mounting Adapter	2737K77
	Clamp	R-A118-105
	Bracket, Screw, and Clamp	R-A118-105M

Port Block and End Ports	Options	Port Size	Model Number	
			BSPG (G) Thread	NPTF Thread
	Extra Port Blocks	1/2	R-118-106-4W	R-118-106-4
	Female End Ports	1/2	R-118-100-4W	R-118-100-4
		3/4	R-118-100-6W	R-118-100-6
Male End Ports	1/2	R-118-109-4FW	R-118-109-4F	
	3/4	R-118-109-6FW	R-118-109-6F	

## REPLACEMENT FILTER ELEMENTS

Filter Elements	Series	Bowl Type	Element Rating	Element Material	Model Number	
	MD3™	Standard	5-µm	Polyethylene	R-A60F-03PE5	
				Sintered Bronze	R-A60F-03E5	
				20-µm	Sintered Bronze	R-A60F-03E4
				40-µm	Sintered Bronze	R-A60F-03E3
	MD4™	Standard	5-µm	Polyethylene	R-A115-106PE5	
				Sintered Bronze	R-A115-106E5	
			20-µm	Sintered Bronze	R-A115-106E4	
			40-µm	Polyethylene	R-A115-106PE3	
	HIGH-CAPACITY Flow to 660 scfm	Standard	5-µm	Sintered Bronze	1656K77	
			40-µm	Sintered Bronze	R-A114-106E3	









# LUBRICANTS, POLYCARBONATE BOWL CAUTIONS

## COMPATIBLE LUBRICANTS

Although air line lubrication is not required for most ROSS valves, other mechanisms in the system may need such lubrication. When a lubricator is used, it should be supplied only with oils which are compatible with the materials used in the valves for seals and poppets. Generally speaking, these are petroleum base oils with oxidation inhibitors, and aniline point between 180°F (82°C) and 220°F (104°C) and an ISO 32, or lighter, viscosity. Oils with phosphate type additives, such as zinc dithiophosphate, must be avoided because they can harm polyurethane valve components. The best oils to use in pneumatic systems are those specifically compounded for air line lubricator service.

## CAUTIONS ON THE USE OF POLYCARBONATE BOWLS

**Use Only with Compressed Air.** Filters and lubricators with polycarbonate bowls are specifically designed for compressed air service, and their use with any other fluid (liquid or gas) is a misapplication. The use with or injection of certain hazardous fluids in the system (e.g., alcohol or liquefied petroleum gas) could be harmful to the polycarbonate bowl or result in a combustible condition or hazardous leakage. Before using with a fluid other than air, or for nonindustrial applications, or for life support systems, consult ROSS.

**Use Metal Bowl Guard When Supplied.** A metal bowl guard is supplied with all but the smallest bowls, and must always be used to minimize danger from fragmentation in the event of failure of a polycarbonate bowl.

**Avoid Harmful Substances.** Some compressor oils, chemical cleaners, solvents, paints, and fumes will attack polycarbonate bowls and can cause bowl failure. Do not use with or near these materials. When a bowl becomes dirty, replace the bowl or wipe it with a clean dry cloth. Immediately replace any polycarbonate bowl which is crazed, cracked, or deteriorated.

## SUBSTANCES HARMFUL TO POLYCARBONATE BOWLS

Acetaldehyde	Carbon disulfide	Ethylene dichloride	Phosphorous trichloride
Acetic acid	Carbon tetrachloride	Ethylene glycol	Propionic acid
Acetone	Caustic potash solution	Formic acid	Pyridine
Acrylonitrile	Caustic soda solution	Freon (refrigerant & propellant)	Sodium hydroxide
Ammonia	Chlorobenzene	Gasoline (high aromatic)	Sodium sulfide
Ammonium fluoride	Chloroform	Hydrazine	Styrene
Ammonium hydroxide	Cresol	Hydrochloric acid	Sulfuric acid
Ammonium sulfide	Cyclohexanol	Lacquer thinner	Sulfural chloride
Anaerobic adhesives & sealants	Cyclohexanone	Methyl alcohol	Tetrahydronaphthalene
Antifreeze	Cyclohexene	Methylene chloride	Thiophene
Benzene	Dimethyl formamide	Methylene salicylate	Toluene
Benzoic acid	Dioxane	Milk of lime (CaOH)	Turpentine
Benzyl alcohol	Ethane tetrachloride	Nitric acid	Xylene
Brake fluids	Ethyl acetate	Nitrobenzene	Perchloroethylene
Bromobenzene	Ethyl ether	Nitrocellulose lacquer	
Butyric acid	Ethylamine	Phenol	
Carbolic acid	Ethylene chlorohydrin	Phosphorous hydroxyl chloride	

## TRADE NAMES OF SUBSTANCES HARMFUL TO POLYCARBONATE BOWLS

Atlas Perma-Guard	Loctite Threadlocker Red 271	Pydraul AC
Buna-N	Loctite Threadlocker 290	Sears Regular Motor Oil
Cellulube #150 & #220	Loctite 601	Sinclair oil "Lily White"
Crylex #5 cement	Loctite Teflon sealant	Stauffer Chemical FYRQUEL 150
Eastman 910	Marvel Mystery Oil	Stillman #SR 269-75 (polyurethane)
Garlock #98403 (polyurethane)	Minnesota Rubber 366Y	Stillman #SR 513-70 (neoprene)
Haskel #568-023	National Compound #N11	Tannergas
Hilgard Company's Hil-Phene	Nylock VC-3	Telar
Houghton & Co. oil #1120, #1130, #1055	Parco #1306 Neoprene	Tenneco Anderol 495 & 500 oils
Houtosafe 1000	Permabond 910	Titon
Kano Kroil	Petron PD287	Vibra-TITE
Keystone penetrating oil #2	Prestone	Valvolin ZEREX

# CAUTIONS, WARNINGS And STANDARD WARRANTY



ROSS OPERATING VALVE, ROSS CONTROLS®, ROSS DECCO®, and AUTOMATIC VALVE INDUSTRIAL, collectively the “ROSS Group”.

## PRE-INSTALLATION or SERVICE

1. Before servicing a valve or other pneumatic component, be sure all sources of energy are turned off, the entire pneumatic system is shut down and exhausted, and all power sources are locked out (ref: OSHA 1910.147, EN 1037).
2. All ROSS Group Products, including service kits and parts, should be installed and/or serviced only by persons having training and experience with pneumatic equipment. Because any product can be tampered with and/or need servicing after installation, persons responsible for the safety of others or the care of equipment must check ROSS Group Products on a regular basis and perform all necessary maintenance to ensure safe operating conditions.
3. All applicable instructions should be read and complied with before using any fluid power system to prevent harm to persons or equipment. In addition, overhauled or serviced valves must be functionally tested prior to installation and use. If you have any questions, call your nearest ROSS Group location.
4. Each ROSS Group Product should be used within its specification limits. In addition, use only ROSS Group components to repair ROSS Group Products.

### WARNINGS:

**Failure to follow these instructions can result in personal injury and/or property damage.**

## FILTRATION and LUBRICATION

1. Dirt, scale, moisture, etc., are present in virtually every air system. Although some valves are more tolerant of these contaminants than others, best performance will be realized if a filter is installed to clean the air supply, thus preventing contaminants from interfering with the proper performance of the equipment. The ROSS Group recommends a filter with a 5-micron rating for normal applications.
2. All standard ROSS Group filters and lubricators with polycarbonate plastic bowls are designed for compressed air applications only. Use the metal bowl guard, where provided, to minimize danger from high pressure fragmentation in the event of bowl failure. Do not expose these products to certain fluids, such as alcohol or liquefied petroleum gas, as they can cause bowls to rupture, creating a combustible condition and hazardous leakage. Immediately replace crazed, cracked, or deteriorated bowls.
3. Only use lubricants which are compatible with materials used in the valves and other components in the system. Normally, compatible lubricants are petroleum base oils with oxidation inhibitors, an aniline point between 180°F (82°C) and 220°F (104°C), and an ISO 32, or lighter, viscosity. Avoid oils with

phosphate type additives which can harm polyurethane components, potentially leading to valve failure which risks personal injury, and/or damage to property.

### WARNINGS:

**Failure to follow these instructions can result in personal injury and/or property damage.**

## AVOID INTAKE/EXHAUST RESTRICTION

1. Do not restrict air flow in the supply line. To do so could reduce the pressure of the supply air below minimum requirements for the valve and thereby causing erratic action.
2. Do not restrict a valve's exhaust port as this can adversely affect its operation. Exhaust silencers must be resistant to clogging and must have flow capacities at least as great as the exhaust capacities of the valves. Contamination of the silencer can result in reduced flow and increased back pressure.

**WARNINGS: Failure to follow these instructions can result in personal injury and/or property damage.**

## SAFETY APPLICATIONS

1. Mechanical Power Presses and other potentially hazardous machinery using a pneumatically controlled clutch and brake mechanism must use a press control double valve with a monitoring device. A double valve without a self-contained monitoring device should be used only in conjunction with a control system which assures monitoring of the valve. All double valve installations involving hazardous applications should incorporate a monitoring system which inhibits further operation of the valve and machine in the event of a failure within the valve mechanism.
2. Safe Exhaust (dump) valves without a self-contained monitoring device should be used only in conjunction with a control system which assures monitoring of the valve. All Safe Exhaust valve installations should incorporate a monitoring system which inhibits further operation of the valve and machine in the event of a failure within the valve mechanism.
3. Per specifications and regulations, the ROSS L-O-X® and L-O-X® with EEZ-ON®, N06 and N16 Series operation products are defined as energy isolation devices, NOT AS EMERGENCY STOP DEVICES.

### WARNINGS:

**Failure to follow these instructions can result in personal injury and/or property damage.**

## STANDARD WARRANTY

All products sold by the ROSS Group are warranted for a one-year period [with the exception of Filters, Regulators and Lubricators (“FRLs”) which are warranted for a period of seven (7) years] from the date of purchase. All products are, during their respective warranty periods, warranted to be free of defects in material and workmanship. The ROSS Group's obligation under this warranty is limited to repair, replacement or refund of the purchase price paid for products which the ROSS Group has determined, in its sole discretion, are defective. All warranties become void if a product has been subject to misuse, misapplication, improper maintenance, modification or tampering. Products for which warranty protection is sought must be returned to the ROSS Group freight prepaid.

THE WARRANTY EXPRESSED ABOVE IS IN LIEU OF AND EXCLUSIVE OF ALL OTHER WARRANTIES AND THE ROSS GROUP EXPRESSLY DISCLAIMS ALL OTHER WARRANTIES EITHER EXPRESSED OR IMPLIED WITH RESPECT TO MERCHANTABILITY OR FITNESS FOR A PARTICULAR PURPOSE. THE ROSS GROUP MAKES NO WARRANTY WITH RESPECT TO ITS PRODUCTS MEETING THE PROVISIONS OF ANY GOVERNMENTAL OCCUPATIONAL SAFETY AND/OR HEALTH LAWS OR REGULATIONS. IN NO EVENT IS THE ROSS GROUP LIABLE TO PURCHASER, USER, THEIR EMPLOYEES OR OTHERS FOR INCIDENTAL OR CONSEQUENTIAL DAMAGES WHICH MAY RESULT FROM A BREACH OF THE WARRANTY DESCRIBED ABOVE OR THE USE OR MISUSE OF THE PRODUCTS. NO STATEMENT OF ANY REPRESENTATIVE OR EMPLOYEE OF THE ROSS GROUP MAY EXTEND THE LIABILITY OF THE ROSS GROUP AS SET FORTH HEREIN.



<b>AMERICAS</b>	<b>ROSS CONTROLS</b>	USA	Tel: +1-248-764-1800	<a href="http://www.rosscontrols.com">www.rosscontrols.com</a>
	<b>ROSS CONTROLS CANADA Ltd.</b>	Canada	Tel: +1-416-251-7677	<a href="http://www.rosscanada.com">www.rosscanada.com</a>
	<b>ROSS DO BRASIL EIRELI</b>	Brazil	Tel: +55-11-4335-2200	<a href="http://www.rosscontrols.com.br">www.rosscontrols.com.br</a>
<b>EUROPE</b>	<b>ROSS EUROPA GmbH</b>	Germany	Tel: +49 (0)6103-7597-100	<a href="http://www.rosseuropa.com">www.rosseuropa.com</a>
	<b>ROSS FRANCE SAS</b>	France	Tel: +33-(0)1-49-45-65-65	<a href="http://www.rossfrance.com">www.rossfrance.com</a>
	<b>ROSS PNEUMATROL Ltd.</b>	United Kingdom	Tel: +44 (0)1254 872277	<a href="http://www.rossuk.co.uk">www.rossuk.co.uk</a>
<b>ASIA &amp; PACIFIC</b>	<b>ROSS CONTROLS INDIA Pvt. Ltd.</b>	India	Tel: +91-44-2624-9040	<a href="http://www.rosscontrolsindia.com">www.rosscontrolsindia.com</a>
	<b>ROSS CONTROLS (CHINA) Ltd.</b>	China	Tel: +86-21-6915-7961	<a href="http://www.rosscontrolschina.com">www.rosscontrolschina.com</a>
	<b>ROSS ASIA K.K.</b>	Japan	Tel: +81-42-778-7251	<a href="http://www.rossasia.co.jp">www.rossasia.co.jp</a>
	<b>AUTOMATIC VALVE INDUSTRIAL LLC</b>	USA	Tel: +1-248-474-6700	<a href="http://www.automaticvalve.com">www.automaticvalve.com</a>
	<b>ROSS DECCO COMPANY</b>	USA	Tel: +1-248-764-1800	<a href="http://www.rossdecco.com">www.rossdecco.com</a>
	<b>ROSS PNEUMATROL Ltd.</b>	United Kingdom	Tel: +44 (0)1254 872277	<a href="http://www.pneumatrol.com">www.pneumatrol.com</a>
	<b>manufactIS GmbH</b>	Germany	Tel: +49 (0)2013-16843-0	<a href="http://www.manufactis.net">www.manufactis.net</a>

## ***Full-Service Global Locations***

### ***There are ROSS Distributors Throughout the World***

*To meet your requirements across the globe, ROSS distributors are located throughout the world. Through ROSS or its distributors, guidance is available for the selection of ROSS products, both for those using fluid power components for the first time and those designing complex systems.*

*Other literature is available for engineering, maintenance, and service requirements.*

*If you need products or specifications not shown in this catalog, please visit ROSS' website, contact ROSS or your ROSS distributor. The ROSS Support Team will be happy to assist you in selecting the best product for your application.*

*For a current list of countries and local distributors, visit ROSS' at [www.rosscontrols.com](http://www.rosscontrols.com).*